

Emery Winslow Scale Company

73 Cogwheel Lane
Seymour, CT 06483
(203) 881-9333
(203) 881-9477 FAX

4530 North 25th Street
Terre Haute, IN 47805
(812) 466-5265
(812) 466-1046 FAX

INSTRUCTION & SERVICE MANUAL

7400 Digital Indicator



Emery
Winslow
SCALE CO

TABLE OF CONTENTS

SPECIFICATIONS.....	3
INSTALLATION.....	4
SETUP ACCESS.....	5
MENU LAYOUT.....	6
CONFIGURATION.....	7
REMOTE SERIAL DISPLAY.....	8
CALIBRATION.....	9
SERIAL PORTS.....	10
SERIAL COMMUNICATIONS.....	11
ANALOG OUTPUT.....	13
DIGITAL INPUT/OUTPUT.....	15
SETPOINTS.....	17
OVER/UNDER.....	17
BATCH MODE.....	18
TIME & DATE.....	19
AC/DC OPERATION.....	19
DISPLAY MESSAGES.....	20
115/220 VAC.....	21
SPARE PARTS.....	22

SPECIFICATIONS:

LOAD CELL A/D CONVERTER

TYPE: 24 bit delta sigma
EXCITATION: 5 VDC, 120 mA max.
SIGNAL INPUT: 16 mv
SENSITIVITY: 0.1 μ V/grad
UPDATE RATE: 30 update/second

DISPLAY: Six (6) Decades, 0.6 inch LED

CONTROLS: "ZERO","GROSS/NET","TARE", "UNITS", "PRINT"

POWER INPUT: 117/217 VAC, 50-60 HZ, 20 watts, fuse 0.25 A Slo-Blow.

SERIAL PORTS:

Port 1: RS232C or 20ma

Port 2: RS485, RS232C or 20mA.

ENCLOSURE: Stainless Steel, NEMA 4x, Tilt - Stand Base, 7lbs.

CASE: 10"(w) x 6.5"(h) x 4"(d)

OPTIONS:

TIME & DATE: 12/24 hr, battery backed.

ANALOG OUTPUT: 0-10v, 4-20ma (16 bit D/A).

DIO: 4 AC/DC – inputs, 4 AC outputs (SS Relays, 0.5 amp)

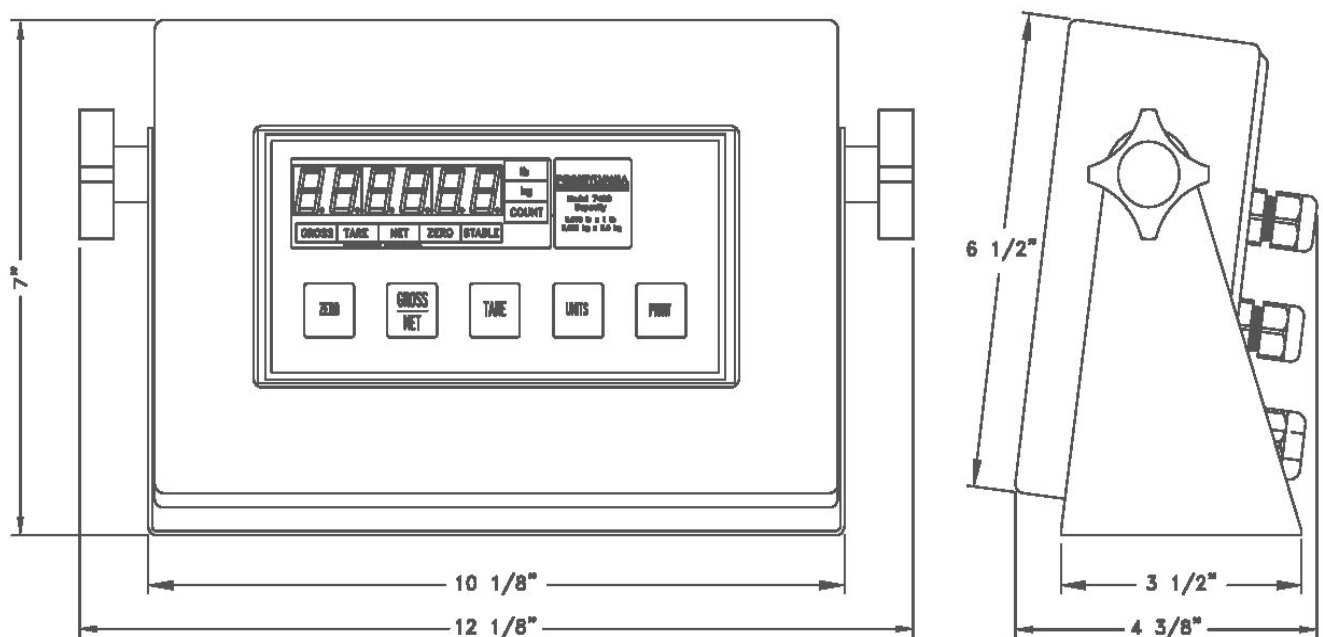

INSTALLATION

POWER WIRING: The indicator is designed to be operated from 117/217 VAC, 50-60 Hz. The unit power cord must be plugged into a grounded 3 - wire polarized AC wall socket. All normal wiring and grounding precautions should be observed, including use of a "clean" AC power line.

SCALE WIRING: The unit is equipped with cable gland entry for load cell cable insertion and internal (pluggable) terminal strip for 4 / 6 wire connection. Remove sense jumpers P11-8/7, P11-6/5 for six wire.

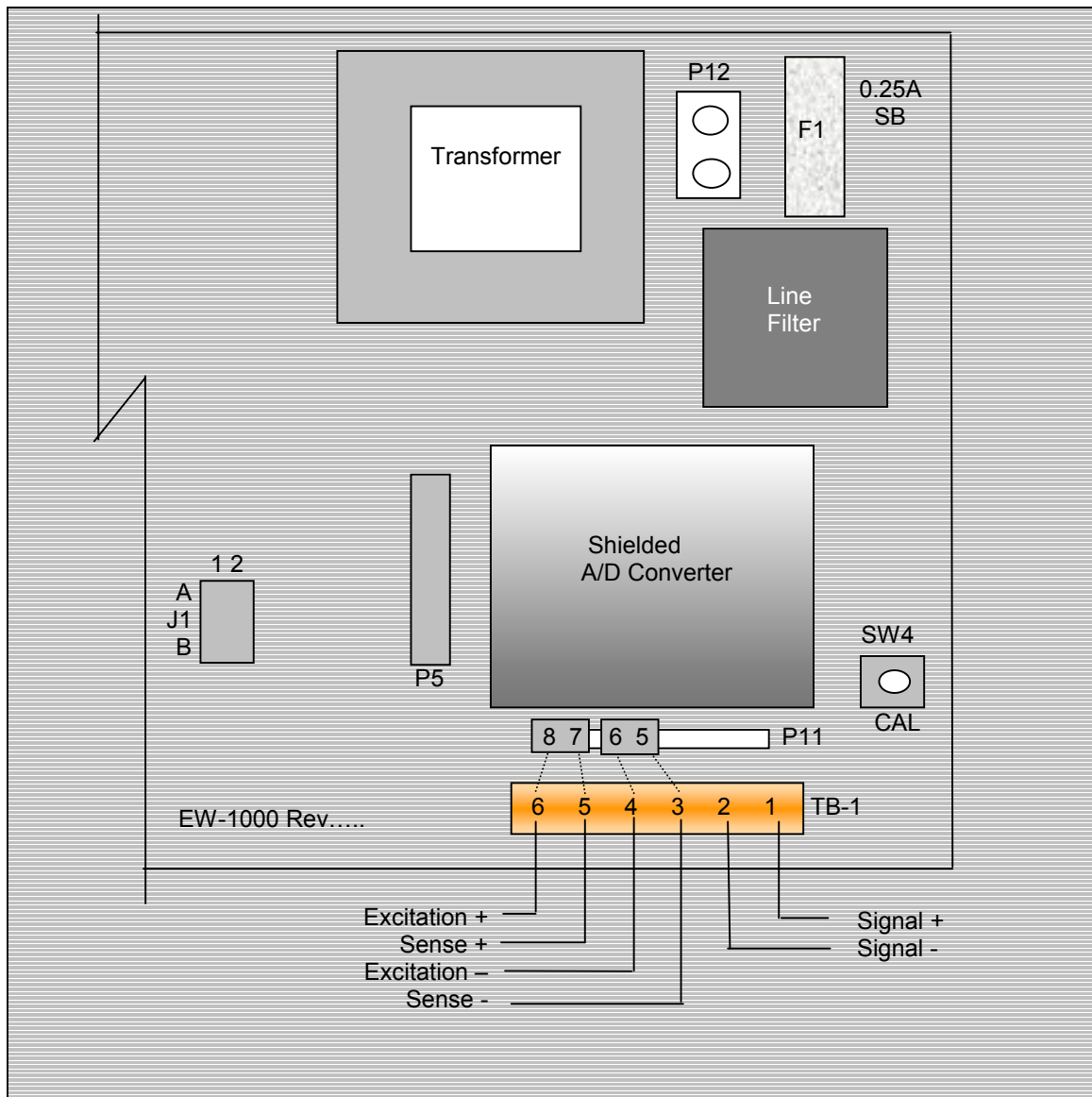

Keypad:



SETUP ACCESS

To access instrument configuration, calibration or to enable options, depress the “Zero” key for five seconds.

The Audit Trail counters (“Pxxx” and “Cxxx”) are displayed first followed by access code request (“AC?”). The initial factory setting is “0000” which can be entered with four steps of the “Gross/Net” key (“AC0000”) and “Print”. If no entry is made, instrument returns to operate mode.

The access code can be changed to any four digit combination during setup exit when display again shows “AC?”. Use the Tare key to increment a digit and Gross/Net to shift the digit position.

The display check feature is accessed during the initial entry point “AC?”, by a second step of the “Zero” key. The software version “V 1.XX” will be displayed followed by a continuous display test routine. Another step on the “zero” key returns to “AC?”.

Front panel access is inhibited if conventional “sealing” is applied by setting jumper J1-1 in the B position. The board mounted “CAL” button is then used for access.

After entry, use the “Gross/net” key to select a main menu; configuration (“SEL.CFG”), calibration (“SEL.CAL”), or options (“SEL.OPX”).

The “Zero” key enters selected menu and is used to step through sub categories. Individual parameter selection is made with the “Gross/Net” key, which then steps through the parameter choices.

The “Print” key is used at any point to “back” up from categories to menus and to “save?” and “AC?” and exit.

During the exit steps, if changes were made, the display is “save?” with alternate “no”. To save changes, use the “Tare” key to select “yes” and “Print” to exit.

Calibration numeric entries are made with “Tare” key incrementing the flashing digit and the “Gross/Net” key shifting the digit selection.

Menu Layout

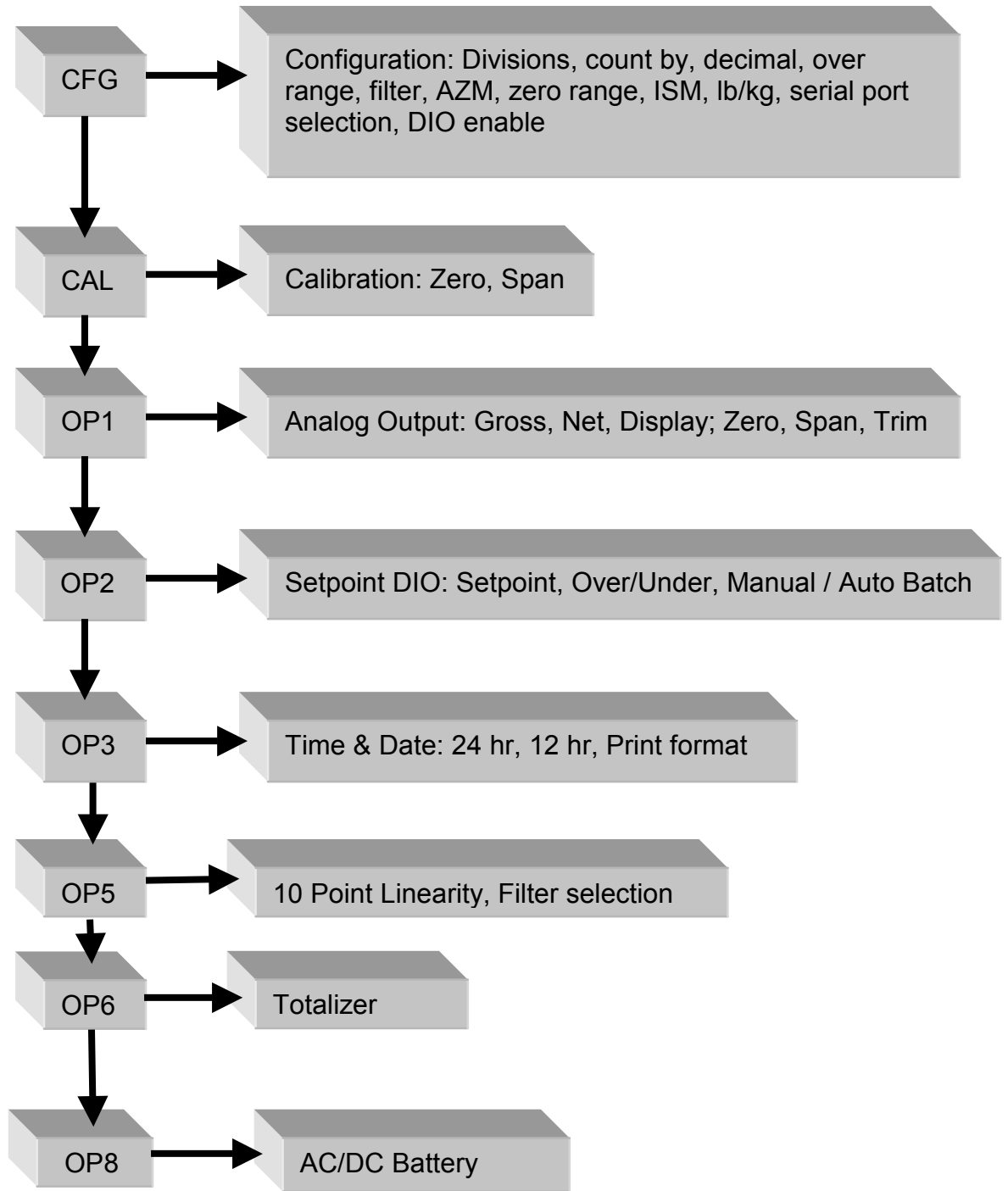

CONFIGURATION: “SEL.CFG” Use Zero to enter the menu and step to each category, Gross/Net to select parameters. Print to return to menu selection.

Capacity is the combination of “1”, “2” and “3”.

Example: 1__100, 2__2 and 3__0.0 = 2,000 x 0.2 lb

Step	Parameters	Definition
1	5, 10, 15, 20...100, 120...1000	Number of divisions x100 100 = 10,000 divisions
2	1, 2, 5, 10, 20, 50, and 100.	Count by selection 10,000 divisions, count by 2 = 20,000
3	0, 0.0, 0.00, 0.000, and 0.0000	Decimal point selection
4	105P, 9 d (105% or 9 divisions)	Overrange selection
5	1, 2, 3, 4, 5, 6, 8, 10, 12, 15.....90	Digital filter selection (averaging)
6	off, 0.5, 1, 3, 5, 10 (divisions)	Auto Zero Maintenance (AZM)
7	1.9, 5, 10, 20, FS (% of capacity)	Zero range selection 1.9% of 2,000 x 0.2 = 38.0 lb
7.1	off, on (ISM)	Zero's scale on power-up
8	off, 1, 3, 5,10 (divisions)	Motion Band selection
9	lb, kg, con	Units selection and convert
10	nt, Gtn, n.nt, n.Gtn.	Port 1 serial output selection nt display only, Gtn is Gross Tare Net and n.nt/n.Gtn inhibit neg gross print
11	off, co, de	Off, Continuous, or Demand
12	7o, 7E, 8n	7- odd, 7- even or 8- none
13	12, 24, 48, 96	Baud rate selection
14	off, 1, 2, 3, 5, 10, 15 (seconds)	Delay between lines or continuous output.
19	A, b	A : adds “STX” in continuous b : No “STX” in continuous
20	nt, Gtn, n.nt, n.Gtn	Port 2 serial output selection
21	off, co, de, Ln	Off, Continuous, Demand, Network
22	7o, 7E, 8n	7- odd, 7- even or 8- none
23	12, 24, 48, 96	Baud rate selection
24	off, 1, 2, 3, 5, 10, 15 (seconds)	Delay between lines or continuous output.
25	1 – 16 (RS485/RS422)	Network address selection
30	off, on	DIO Inputs

Remote Serial Display (RSD) Option

In RSD mode the instrument can be set to work with another unit as a “remote” either as the main or the slave unit. Communication is pre-set for channel two only on both units.
(RS232, 9600, 8, none)

When in remote mode, re-access to the following selections requires using the internal “cal” switch.

Remote unit can have full or partial control of the main unit. Devices are available to replace the cable for wireless communication.

40	rd.OF, rd.En, rd.re	rd.En : Selects Indicator as Remote Display (RSD) rd.re : Allows indicator to operate w/RSD
41	En.On	Allow remote keypad operation
42	Zr.On	Enable/Disable zero key
43	tr.On	Enable/Disable tare key
44	Un.On	Enable/Disable unit key
45	Pr.On	Enable/Disable print key
46	Fn.On	Enable/Disable all other functions

CALIBRATION: “SEL.CAL” Use Zero to enter the menu indicated by a flashing “C” on the left and live weight is displayed. Scale zero (dead load) or adjusting span (single or multi-point) are independent. Therefore either can be done and repeated as necessary before exiting calibration. If an error has been made, exit without “storing” will return to prior setup.

KEY (FUNCTION)	DISPLAY	Definition
(Live weight 123 lb)	“C”__123	Cal mode scale reading
Zero (acquire dead load)	“-----“ to “C__0.0”	acquires new dead load
(live weight 5000 lb)	“C”__4995	Scale reading with load
Gross/Net (adjust span)	004995	freezes display for adjustment
Gross/Net (select digit)	00499”5”	digit flashes
Tare (increments digit)	00499”0”	Increments
Gross/Net (select digit)	0049”9”0	digit flashes
(Adjustment complete)	005000	adjusted value

Then with Print:

(adjust span) “-----“ to “C” 5000 displays new span

Repeat as required then use Print to exit CAL.

“Save ?” “No” or “Save ?” “Yes” use Tare to select and Print to store “yes” with changes or “no” to exit without changes.

Continue with Print to “Ent AC” which allows access code change by entering a new four digit code and press again or skip with no entry.

Option 5 Ten point calibration: Allows up to 10 span points (pt1.....pt10). Zeroing the scale clears the existing values. Points are assigned incrementally with error indication if the addition is not above the prior point or exceeding scale capacity.
Filter selection included for rolling or box averaging.

5.1	OFF, On	Enable 10 point span
5.2	A, b	A : Rolling average B : Box average

SERIAL PORTS

Port 1: RS232 duplex (Rx,Tx), 20ma (Tx).

Port 2: RS232 duplex (Rx,Tx), 20ma (Rx,Tx), RS485, or RS422.

Note: Position jumper on J2 for Port 2 receive selection.

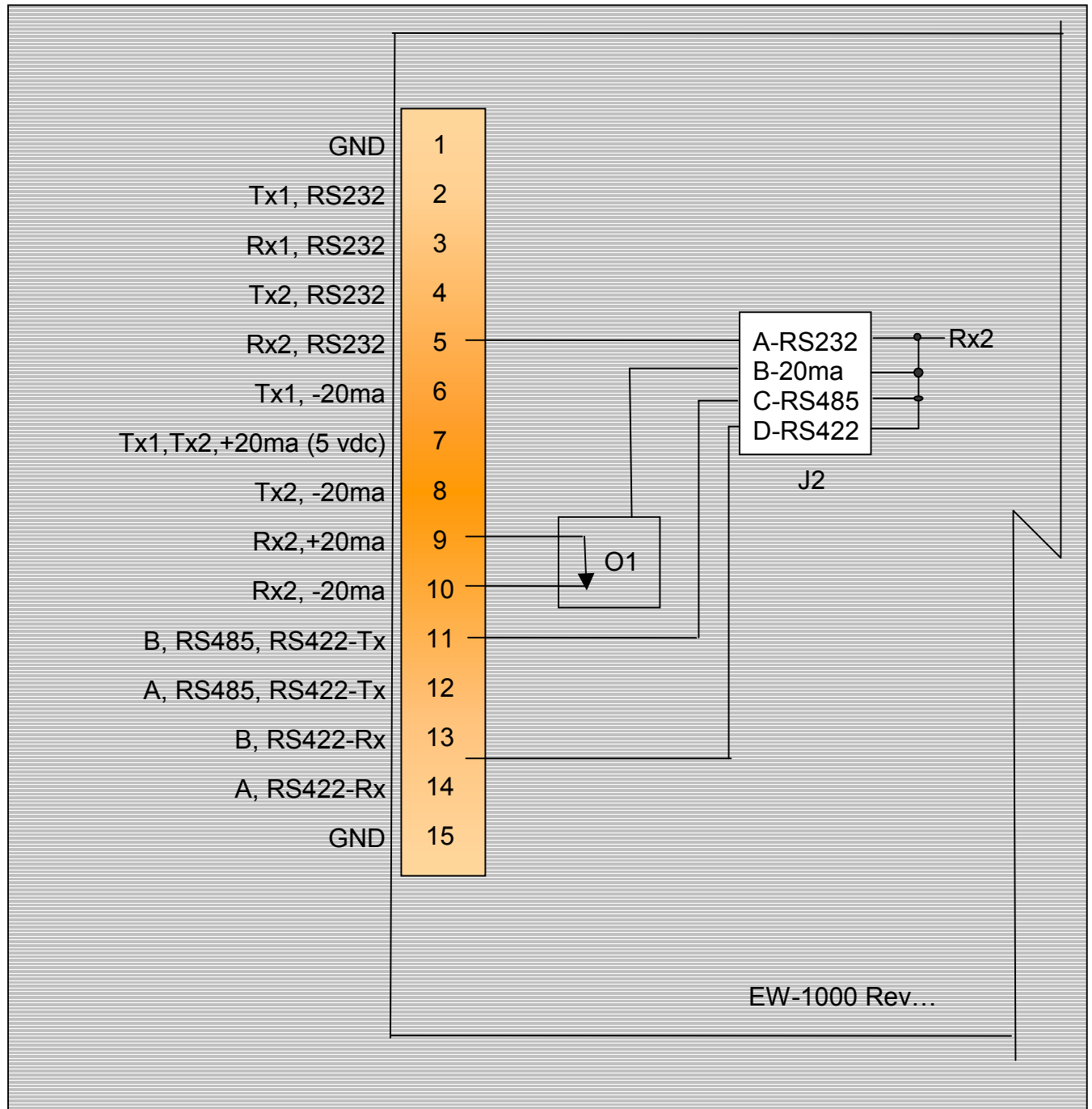

Serial Communications

Remote Commands

<Z><cr>	Zero Scale	“Gross” mode, no motion, inside zero range.
<N><cr>	Switch to Net	“Gross” mode with Tare stored.
<G><cr>	Switch to Gross	“Net” mode.
<T><cr>	Auto Tare	Switch to Net, no motion, not at “Gross” zero.
<P><cr>	Print	Valid display, No motion

Data Formats

Demand Mode: <stx><pol><DATA><sp><lb/kg><sp><GR/NT><cr/lf>

Continuous Mode: <stx><pol><DATA><L/K><G/N><status><cr/lf>

Brackets “<>” are not sent

stx: “Start of Text” character (ASCII 002) (can be removed in continuous: config 19)

pol: Polarity sign, “SPACE” (ASCII 032) for positive or (-) sign (ASCII 045) for negative

sp: Space character (ASCII 032)

DATA: Seven (7) digit data field including decimal point or fixed (dummy) zero if selected.
“Leading Zero Suppression” with leading zeros transmitted as “space” characters.

lb/kg: Two (2) character field data identification for weight units, in demand (printer) mode.

Weight in lb = “lb” (ASCII 108,098), weight in kg = “kg” (ASCII 107,103)

L/K: One (1) character field data identification for weight units in continuous (computer) mode.

Weight in lb = “L” (ASCII 076), weight in kg = “K” (ASCII 075)

GR/NT: Two (2) character field data identification for weighing mode in demand (printer) mode.

Gross Mode = “GR” (ASCII 071,082), Net Mode = “NT” (ASCII 078,084)

G/N: One (1) character field data identification for weighing mode in continuous (computer) mode.

Gross Mode = "G" (ASCII 071), Net Mode = "N" (ASCII 078)

status: One (1) character data identification used in the continuous (computer) output mode to identify the status of the indicator. Characters are listed below in order of priority.

Calibration/configuration	<D> (ASCII 068)
Over/Under Range	<O> (ASCII 079)
Motion	<M> (ASCII 077)
Center of Zero	<C> (ASCII 067)
None of the above	<sp>(ASCII 032)

cr/lf: Two (2) character field, "Carriage Return" (ASCII 013), "Line Feed" (ASCII 010)

Guidelines for Serial Output:

Demand format will inhibit "print" when scale is in "motion" or with negative "Gross" weight, even in "Net" mode (based on setting "CFG 10").

Local Network Protocol:

Command to the indicator:

<*><DD><00><cmd><data entry><CR>

Response from indicator:

<:><00><DD><cmd echoed><data resp><CR>

Where: (<,> brackets not sent)

*	= Message from master (2AH)
DD	= Indicators address
00	= Master address (fixed at 00)
CR	= Message terminator (ODH)
:	= Response from indicator (3AH)
cmd	= Command to indicator
cmd ech	= Command echoed from indicator
data ent	= Data entered into indicator
data resp	= Data response from indicator

OPTION 1: Analog Output

0 – 10 Vdc or 4 – 20 ma, select with jumpers J1 and J2

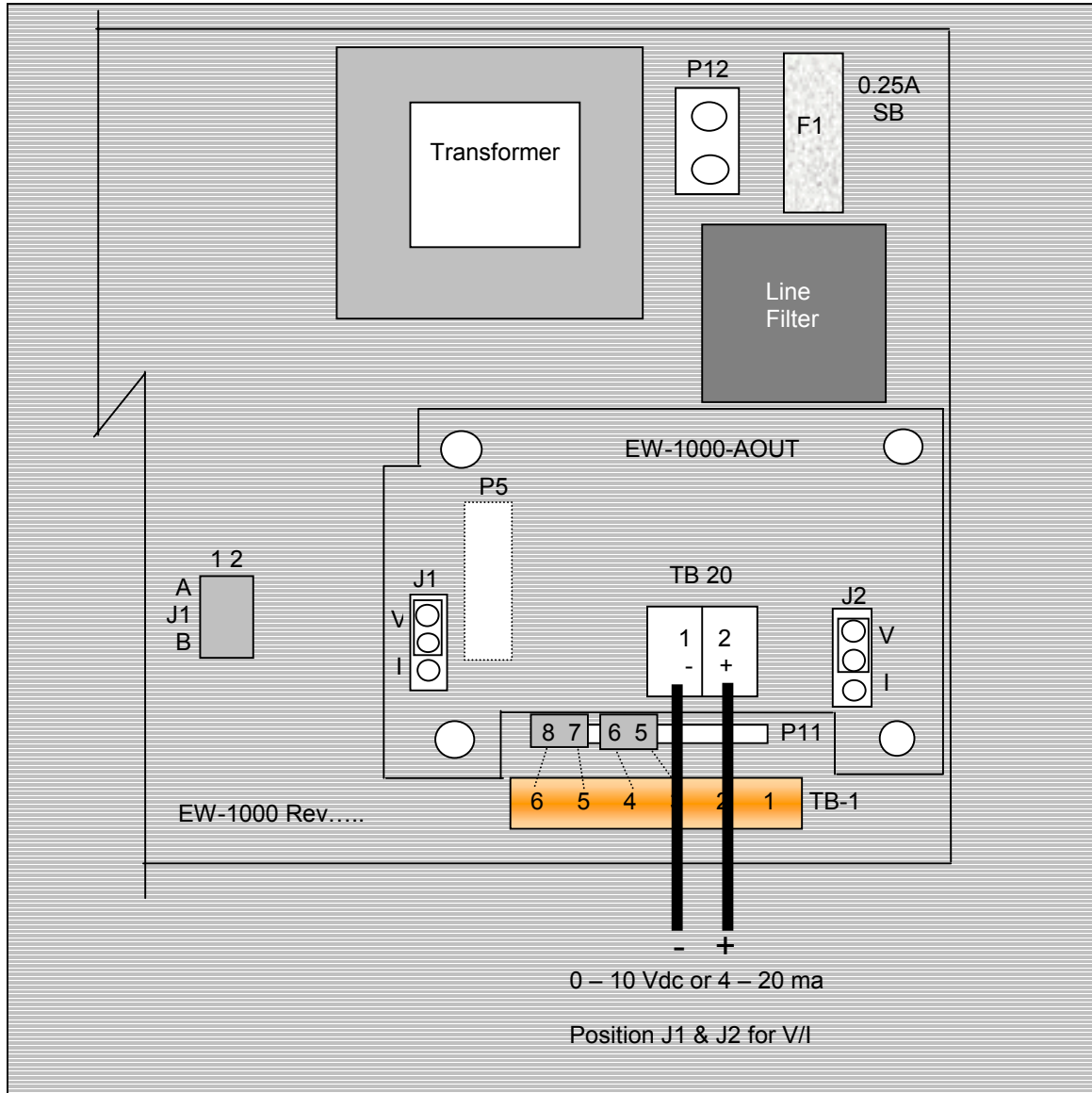

Option 1 Analog Output: "SEL.OP1" Use Zero to enter the menu and step to each category, Gross/Net to select parameters. Print to return to menu selection.

DISPLAY	Parameters	Definition
1.1__Gr	Gr, Net, DSP	Analog tracks gross, net or display
"1.5__Zr" "0.00" (flashes current analog starting point)		
Gross/Net (select digit)	0000"0"	digit flashes
Tare (increments digit)	0000"5"	Increments
Gross/Net (select digit)	0000"2"5	digit flashes
(Adjustment complete)	000025	adjusted value

Print to adjust starting point.

"1.5__Zr" "0.25" (flashes current analog starting point)

"1.6__FS" "0.00" (flashes current analog span point)

Gross/Net (select digit)	00"0"000	digit flashes
Tare (increments digit)	00"5"000	Increments
(Adjustment complete)	005000	adjusted value

Print to adjust span point.

1.7__ZrA While monitoring the output, use Unit to decrease, Tare to increase the analog reading (Zero trim digi-pot).

1.8__FSA While monitoring the output, use Unit to decrease, Tare to increase the analog reading (Span Trim digi-pot).

Print to exit OP1.

OPTIONS 2: DIO

AC Inputs; D1, D2 are not installed, J1 = short (underside), J2 = open, R1 – R4 = 18k (3w, 5%, flame proof).

DC Inputs; D1, D2 are installed, J1 = open (cut trace), J2 = short, R1 – R4 = 1.5k (1/2w, 5%, carbon film). AC Outputs; Solid State Relays, 120VAC, 0.5A

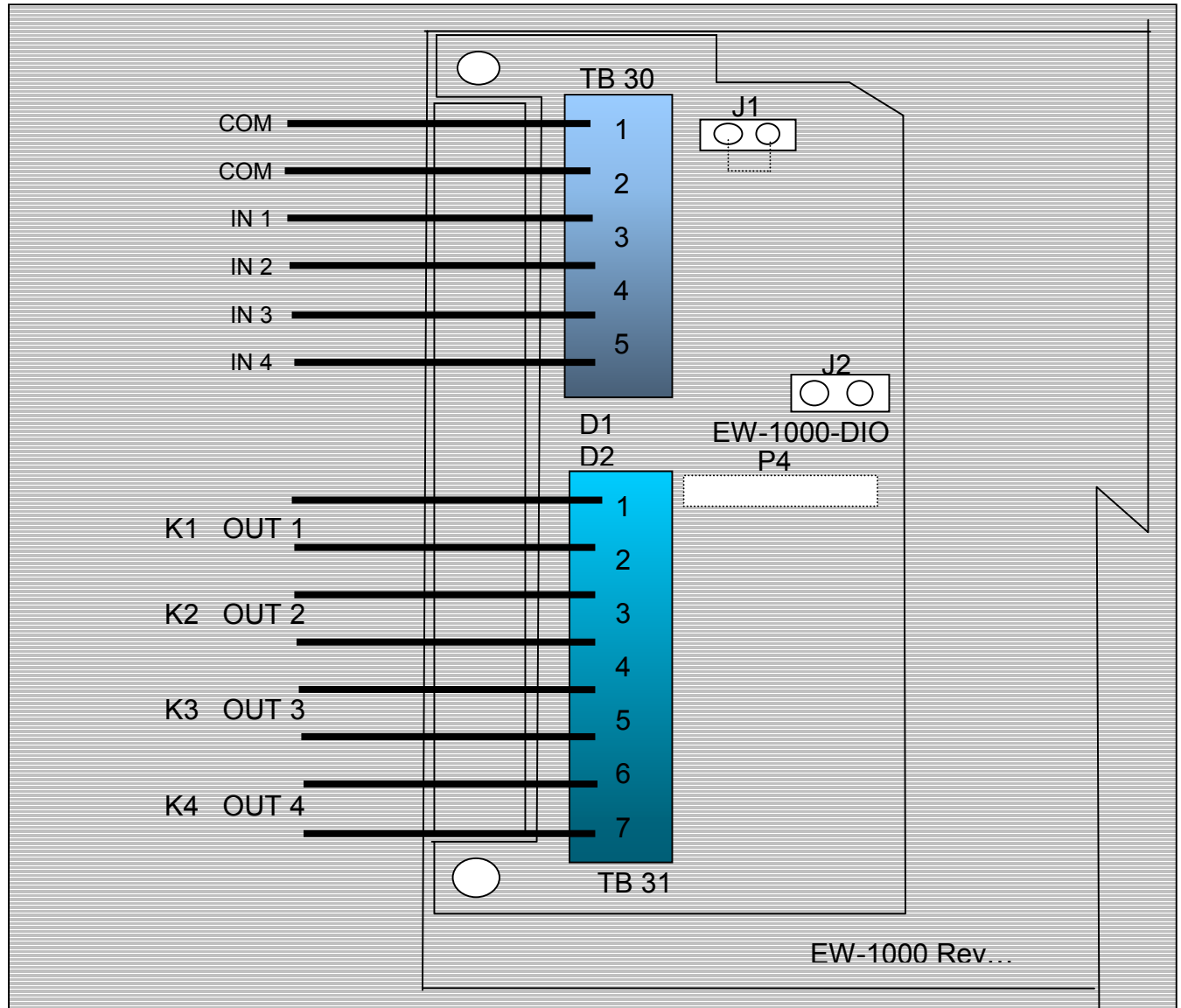

Option 2 DIO: “SEL.OP2” First select the operating mode for “Setpoint”, “Over/Under”, “Manual or Auto Batch”. After setup, the parameters for the selection are entered from the weighing mode.

Use Gross/Net to enter the menu and step to each category, Tare Recall to select parameters. ENT to return to menu selection.

Note: external Inputs are enabled in Configuration with “CFG 30”.
DIO Inputs can be configured for 120vac, 5vdc or dry contact.

	Normal	Batch
IN 1	Gross/Net	Stop
IN 2	Tare	Start
IN 3	Zero	Zero
IN 4	Print	Print

DIO Outputs are 120vac (0.5 amp) or optional 24 vdc, based on operating mode:

	Dual	Setpt 1	Setpt 2	Ov/Un	Man B	Auto B
Out 1	Setpt1-A	Main 1	Main 1	Low	Main 1	Main 1
Out 2	Setpt1-B	Fast F1	Fast F1	Accept	Fast F1	Fast F1
Out 3	Setpt2-A	Tol	Main 2	High	Main 2	Main 2
Out 4	Setpt2-B	Zero B	Fast F2	Zero	Zero	Fast F2

Checkweigher “Bar” graph legends:

Ck1-3	Out Low	Low	Accept	High	Out High
-------	---------	-----	--------	------	----------

Setpoint values are entered from “Weighing Mode” by the SET key and direct numeric entry.

Weight errors of any kind (e.g., ol, ul, etc) will de-energize all relay outputs and abort a batch if one is in progress.

Four outputs are available to use as two setpoints with main and fast feed, single setpoint main and fast feed plus tolerance and zero band. Also Pre-Act can be applied to the main, for material in-flight compensation.

Step	Parameter	Definition
2.0	OFF, SP, OU.UN, bAt1, bAt2	Mode select: setpoint, over/under (check weighing), Manual Batch, Auto Batch
2.0	SP	Setpoint
2.2	Off, s1, s1.p, s1.d, s.p.d, Dual	Setpoint. 1 + pre-act, + drib, + both, Set1-A&B.
2.3	Gr, nt, dSP, Count	Setpoint 1 tracks Gross, Net, Display, Count
2.4	POS, ZER	Output on below reading (POS), inverted (ZER)
2.6	Off, s2, s2.p, s2.d, s2.p.d, tOL, Dual	Setpoint. 2 + pre-act, + dribble, + both, Tolerance, Set2-A&B.
2.7	Gr, nt, dSP, Count	Setpoint. 2 + pre-act, + dribble, + both
2.8	POS, ZER	Output on below reading (POS), inverted (ZER)
2.10	ZbO	Zero band output (input weight value)
2.11	Off, On	Hysteresis, provides 3 grads to prevent relay chatter
s.p.d example	SP1.trG (Target) = 1000 SP1.PrE (Pre-act) = 5 SP1.drb (Dribble) = 10	Main and Fast Feed are on until reading reaches 990, then Fast Feed turns off and Main continues until Pre-act at 995

2.0	OU.UN	Over/Under – check weighing
2.2	Off, HL, tGt, Ck1, Ck2, Ck3	High/Low band, Target and +/- band, Check Weigher 1-3.
2.3	Gr, net, dSP	Outputs track Gross, Net, Display
2.4	POS, ZER	Invert low
2.5	POS, ZER	Invert accept
2.6	POS, ZER	Invert high
2.10	ZbO	Zero band output (input weight value)
2.11	Off, On	Hysteresis, provides 3 grads to prevent relay chatter
2.12	Off, On	Enables “Bar” graph legends
HL example	Low = 950 High = 1050	Then low is on until 950, then accept is on until 1050 and high is on above 1050.
tGt example	Target = 1000 Low = 50 High = 50	Outputs match above example for HL

Note:	Batch printouts are from Port 1 only	
2.0	Bat 1	Manual Batch mode, pauses between setpoints
2.1	Prn, tAr, dIn	7400 uses print, tare or external (DIO) for start. Pressing any key other than “start” will pause and a second push will abort. 7600E uses Start/Stop panel switch
2.2	Off, s1, s1.p, s1.d, s.p.d	Setpoint. 1 + pre-act, + dribble, + both
2.3	Gr, nt, dSP, Count	Setpoint 1 tracks Gross, Net, Display, Count
2.4	POS, ZER	Output on below reading (POS), inverted (ZER)
2.6	Off, s2, s2.p, s2.d, s2.p.d	Setpoint. 2 + pre-act, + dribble, + both
2.7	Gr, nt, dSP, Count	Setpoint. 2 + pre-act, + dribble, + both
2.8	POS, ZER	Output on below reading (POS), inverted (ZER)
2.10	ZbO	Zero band output (input weight value), available if S2 dribble not used

2.0	Bat 2	Auto Batch mode, continues without pause
2.1	Prn, tAr, dIn	7400 uses print, tare or external (DIO) for start. Pressing any key other than “start” will pause and a second push will abort. 7600E uses Start/Stop panel switch
2.2	Off, s1, s1.p, s1.d, s.p.d	Setpoint. 1 + pre-act, + dribble, + both
2.3	Gr, nt, dSP, Count	Setpoint 1 tracks Gross, Net, Display, Count
2.4	POS, ZER	Output on below reading (POS), inverted (ZER)
2.5	Off, 1, 2, 3,, 10	Time Delay (settling) before print
2.6	Off, s2, s2.p, s2.d, s2.p.d	Setpoint. 2 + pre-act, + dribble, + both
2.7	Gr, nt, dSP, Count	Setpoint. 2 + pre-act, + dribble, + both
2.8	POS, ZER	Output on below reading (POS), inverted (ZER)
2.9	Off, 1, 2, 3,, 10	Time Delay (settling) before print
2.10	ZbO	Zero band output (input weight value), available if S2 dribble not used

OP3	Time & Date	
3.1	---, 24H, 12A, 12P	Skip time, 24 hour, 12 hour am, 12 hour pm
3.2	T1	Set time: hh mm ss
3.3	dA	Set date: mm dd yy
3.4	S.no, no, Let	Month print selection, short numerical (mm/dd/yy), number 01 thru 12, month spelled out
3.5	Off, Un, Ab, On	Print under, above or on the same line

OP5	10 Point Linearity	On, Off see page 8
OP6	Totalizer	
6.1	Off, On	Enable Totalizer (operates with Batch or Print)
6.2	Off, 1.....50	Totalizer reset band

Option 6 Totalizer: Operates with “print” function in normal mode or batch mode.

In normal mode, current value is added to the totalizer with each “Print” command. The reset band is used to inhibit a double add when not in Batch Mode.

View the Total with the “2” key and during the display (AC..XXXX), the “Print” key is used to print the total, the “Ent” key returns to weigh mode.

The “Clear” key is used to clear the totalizer by first changing the message from “Clr.ACC...no” to “Clr.ACC...yes” with the “Units” key and “Ent” to complete. A “Cleared” message is provided for conformation.

Note: Totalizer works with port 1 only and the “Print” key is disabled when Batch Mode and Totalizer are both enabled.

Option 8: AC/DC operation

8.1	Off, On	Enables battery charger
8.2	Off, 5, 15, 30, 90, 120	Auto shutoff in minutes, timer resets with motion

DISPLAY MESSAGES

MESSAGE	DESCRIPTION
DAC	D/A card detected - Displayed under the check function.
IIC.ERR	IIC short - Power-up hardware failure indication.
RST	EEPROM is reset by EER command - Power-up message
ON	Displayed on power-up when the DC power push-button is pressed.
AUTO	EEPROM is reset - Power-up message
ERR6.x	Key-pad key is stuck.
-232-	Serial calibration/setup is active.
UPDATE	Enhancement calculation in progress.
LO.BATT	Low battery
D BATT	Dead battery
ULULUL	Under-load (-400 graduations under dead-zero)
OLOLOL	Over-load (+9 graduations or 105% from dead-zero reference)
-----	A/D acquisition is in progress.
7x00	Instrument mode selection.
Err 10	Number > 999999
Err 13	Number < -99999
ADC.Err	A/D hardware failure (channel one only).
CHECK	Check mode accessed.
rC.xxxx	Lower four-digits of the ROM check-sum.
Err.80	Serial command data error.
Err.81	Unknown serial command.
-CAL-	Remote calibration
Err.OFF	Hardware failure of the D.C. power on/off circuitry.
RTC.RST	The clock is reset to 01:01:04 12:00:00am.
RST ID	The ID EEPROM has been reset since it was detected as corrupt.
AC OK	Access code entered has been accepted.
E-1234	EEPROM set 1,2,3, and/or 4 have been fixed.
Err 40	Positive or negative signal overload (check sense connections).
Err 31	Bad tare entry
Err 30	Push to Zero out of range
PC Err	Piece Weight Entry is out of range

115 to 220 VAC Conversion : EW1000 Bottom Side

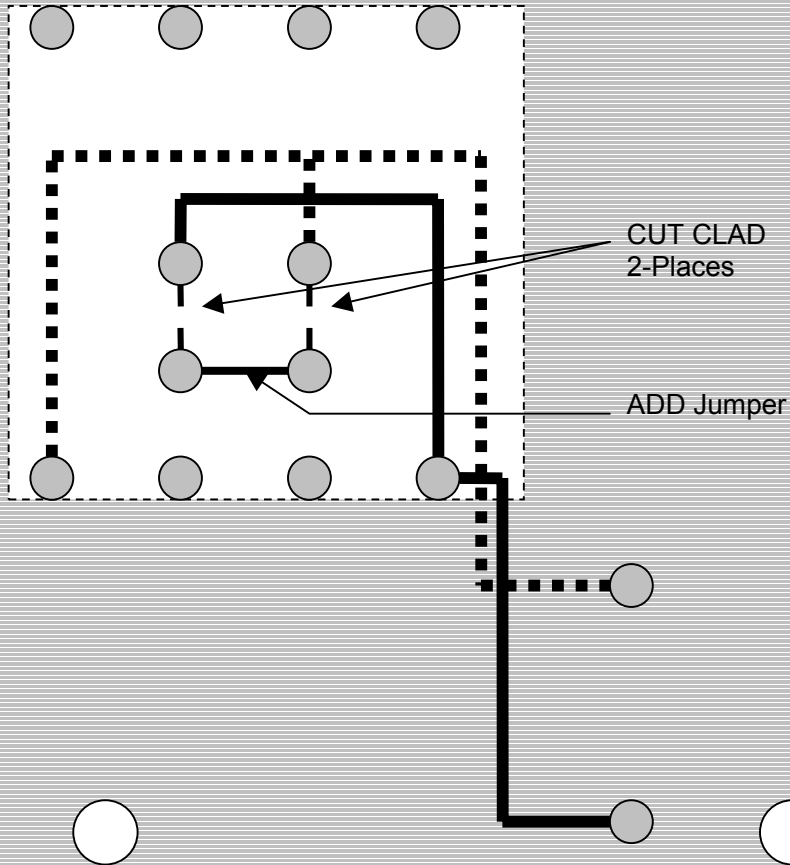

Spare Parts 7400	
Part No.	Description
57819	Main Board
57512	Display Board
57820	Keypad Overlay
57675	Display Cable
56734	Load Cell T-Strip Conn.
	U-Bkt
56734	U-Bkt Knobs
	Enclosure
57811	Analog Output
TBD	Setpoint AC input
TBD	Setpoint DC input
	Second Channel