

HUB-40EX

EXPLOSION-PROOF FREQUENCY OUTPUT SENSOR



Operation & Installation Manual

Rev. 1.3

HUB-40Ex USER MANUAL

Introduction/ Features:

The HUB-40Ex is a frequency output, pickup sensor certified for use in explosion proof areas. The sensor detects the rotation of an approved flow meter's gears and emits a frequency signal proportional to the flow. The output signal is a square wave pulse, which has a duty cycle of approximately 50%. MAG signal outputs are protected with a self-resetting fuse. This fuse has a 50 mA nominal trip point. When a trip occurs, turn off power to the sensor and remove output load to reset the fuse.

Compatible flow meters include:

- JVM-zzz-Ex Models
- JVS-zzz-Ex Models
- JVHS-zzz-Ex Models
- ZHM-zzz-Ex Models
- HPM-zzz-Ex Models
- HM-zzz-AC-Ex Models

Specifications:

- **Supply Voltage:** 10 to 24 VDC
 - **Supply Current:**
 - 8 mA @ 12 VDC
 - 12 mA @ 24 VDC
 - 65 mA MAXIMUM
 - **Sensor/Monitor Frequency Output:** Flow dependent, 0.5 Hz minimum
 - **Output Amplitude:**
 - $V_{HIGH} = V_{SUPPLY} - 0.7$ Volts
 - $V_{LOW} = 0$ Volts
 - **Duty Signal:** 50% \pm 15%
- **Connections:** terminal block, 1/2" NPT (FEMALE) conduit entrance.
 - **Temperature Ratings:**
 - -20°C to +60°C (-4°F to +140°F) ambient
 - 85°C (185°F) maximum fluid temperature
 - **HUB-40Ex Certifications:**
 - CSA
 - CL. I, DIV. 1, GR. C,D
 - CL. II, DIV. 1, GR. E,F,G
 - CL. III
 - **Enclosure Certifications:** TYPE 4X

HUB-40Ex Dimensions:

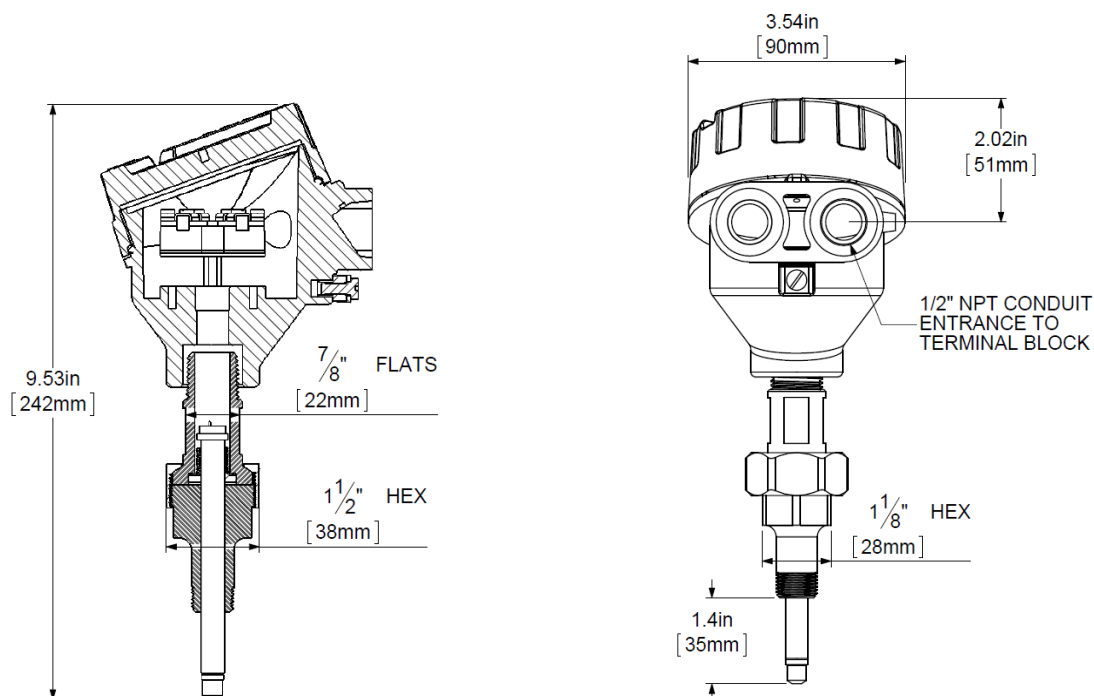

Special installation instruction for use in Hazardous Area environments

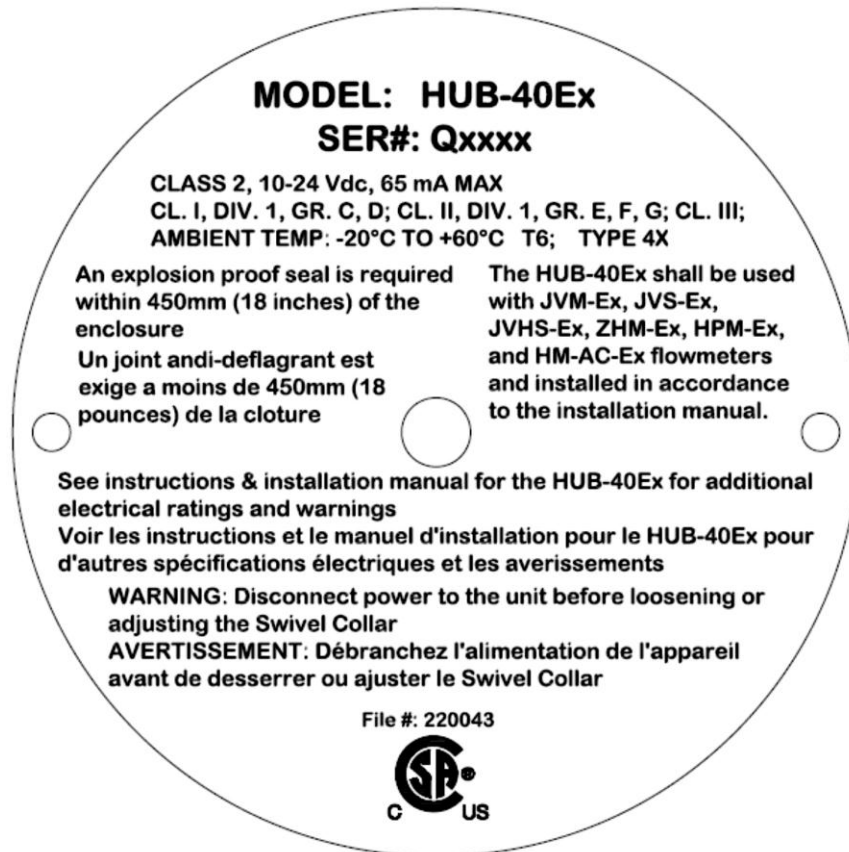

Figure 1: Hazardous Area certification tag

HUB-40Ex models are explosion-proof flow meter sensors, which may be used in Class I, Division 1 locations. Figure 1 above is a sample of the nameplate that should be clearly attached to each unit. Please make sure this nameplate is on the unit and that the information matches what is shown above, prior to installation. If either the nameplate is not on the unit or the unit nameplate does not match what is shown above, please notify AW-Lake Company to determine appropriate course of action.

When installing the HUB-40Ex into an AW-Lake Company flow meter make sure the 3/8" NPT male portion of the sensor housing is engaged by a minimum of five (5) threads into the flow meter in order to maintain the unit's explosion proof rating. HUB-40Ex models must be properly installed into a flow meter before power is applied. NOTE: It is strongly suggested to use anti-seize grease on threads prior to installation to avoid galling.

Because the HUB-40Ex uses an explosion proof enclosure for its area protection, power must be removed from the unit before covers are detached and seals are disconnected while in a hazardous area.

For proper installation, it is also necessary that the conduit entries on the junction box are properly sealed. To maintain the unit's explosion proof rating, anything threaded into the NPT conduit openings must engage by a minimum of five (5) full threads. Original units received from AW-Lake Company are properly installed with a minimum five (5) full threads of engagement when connected to a junction box and should not be tampered with. NOTE: It is strongly suggested to use anti-seize grease on threads prior to installation to avoid galling.

When wiring the unit, please make sure to observe any national or local codes that may be required. An explosion-proof seal is required within 18 inches (450mm) of the unit. Make sure units are powered by a Class 2 power supply for proper regulation. NOTE: Power must be removed from the unit before the Swivel Collar on the hub adapter can be loosened or adjusted.

Removal of the external housing ground terminal is not permitted for safety reasons. Please make sure to follow local electrical code practices when installing equipment in hazardous areas.

Installation:

- Ensure that the sensor cavity of the flow meter is free of debris prior to installation.
- Mount the HUB-40Ex into the sensor cavity and fasten threads. NOTE: REFER TO SECTION TITLED *Special installation instruction for use in Hazardous Area environments* FOR PROPER INSTALLATION REQUIREMENTS!
- Slightly loosen Swivel Union nut and adjust the junction box in the desired orientation.
- Tighten the Swivel Union nut while maintaining the orientation of the junction box. To properly seal surfaces from external environment, apply 65 ft-lbs (+/- 4 ft-lbs) of torque. It is recommended to use anti-seize grease on threads to avoid galling.
- Remove conduit plug from the junction box to allow wire access, and remove the junction box lid to allow access to terminal block connections.
- Connect the wires to the appropriate terminals shown in the wiring guide.
- Reapply the junction box lid until fully engaged and fasten setscrew.
- Seal off conduit connection. NOTE: REFER TO SECTION TITLED *Special installation instruction for use in Hazardous Area environments* FOR PROPER INSTALLATION REQUIREMENTS!

Wiring Guide:

CUSTOMER CONNECTIONS:

TERMINAL 1: NO CONNECTION

TERMINAL 2: EARTH GROUND (⊕)

TERMINAL 3: GROUND/SUPPLY (-)

TERMINAL 4: SIGNAL (FREQ. PULSE)

TERMINAL 5: SUPPLY +10-24 Vdc

TERMINAL 6: NO CONNECTION

6 POSITION TERMINAL BLOCK

