



ISO Registered Company

MODELS 8310LP AND 8310HP

PRESSURE REDUCING REGULATORS

The Models 8310LP and 8310HP are high capacity, self-contained pressure reducing regulators with a double-seat design. These units are utilized to control outlet (downstream) pressure between 1 – 200 psig (.07 – 13.8 Barg). Available in two outlet pressure designs; the Low Pressure, LP design has larger diaphragm for reduced pressures up to 30 psig (2.07 Barg), and the High Pressure design has a smaller diaphragm for reduced pressures up to 200 psig (13.8 Barg).



Model 8310HP



Model 8310LP

FEATURES

- High Capacity:** The double ported design provides high flow capacity, the highest capacity regulators Cashco manufactures due to dual ports.
- High Stability:** Outstanding operation resulting from balanced design which minimizes imbalance plug forces, even at very high pressure drops. Diaphragm isolated from fluid velocity effects.
- Heavy Guiding:** Plug is top and bottom guided with hardened stem guides.
- Broad Setpoint Range:** 8310LP: 1–30psig(.07–2.07Barg)
8310HP: 10 – 200 psig (.7 – 13.8 Barg)
- High Pressure Drop Capability:** 8310LP: Up to 200psid (13.8Bard).
8310HP: Up to 450psid (31.0Bard).

APPLICATIONS

Designed for controlling a wide range of fluids including air, inert gases, chemicals, water, fuel oils and steam. See Table 4 for more information.

STANDARD GENERAL SPECIFICATIONS

Variations: LP – “Low Pressure” variation, larger diaphragm area.
 HP – “High Pressure” variation, smaller diaphragm area.

Body Sizes: 1-1/2", 2", 2-1/2", 3" and 4"
 (DN40, 50, 65, 80, 100)
 (Complies with ASME B16.4 and B16.34)

End Connections: NPT – 1-1/2" and 2" (DN40, 50) sizes only.
Opt-30: Integral Flanged:
 CI with 125 lb. FF, CS with 150 lb. RF
 CI with 250 lb. RF, CS with 300 lb. RF
 Flanges – all sizes.
Opt-34: 14" Face to Face Flange
 Dim. (CS - Sizes 1-1/2" & 2" only)

(Complies with ASME B16.5 and B16.1)

Body / Spring Chamber Material Combinations:
 8310HP: CI/DI, CS/CS
 8310LP: CI/CI, CS/CS
 CI = Cast Iron
 DI = Ductile Iron.
 CS = Cast Carbon Steel.

Inlet Pressure: 8310LP: Up to 200 psig (13.8 Barg).
 8310HP: Up to 650 psig (44.8 Barg).

Outlet Pressure: 8310LP: 1 – 30 psig (.07 – 2.07 Barg).
 8310HP: 10 – 145 psig (.7 – 10 Barg).
 8310HP-80: 130 – 200 psig (9.0 – 13.8 Barg).

External Sensing: 3/8" NPT steel needle valve for downstream sensing connection.

Inlet Temperature: -20° to +450°F.
 (-29° to +233°C.)

Gaskets:
Standard:
 Gaskets – Graphite/ NBR,
 TFE/AL-Silicate.
 O-ring – TFE.

Seat Leakage: FCI 70-2

Trim Design: 316 SST, metal seated, balanced, double seated. Three material combination choices.

Capacities: Up to 100 Cv.

Painting: Standard: All non-corrosion resistant portions to be painted with corrosion resistant epoxy paint per Cashco Spec #S-1606.

Alternate: See Opt-95 or -95OS.

NOTE: Refer to “OPTION SPECIFICATIONS” for alternative designs, and to the “TECHNICAL SPECIFICATIONS” tables for a more complete description of the above specifications.

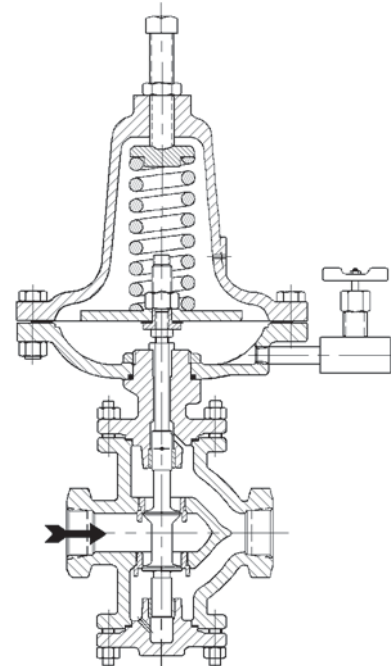

Model 8310HP

OPTION SPECIFICATIONS

This section indicates special variations which are available to the standard Model 8310 products. Multiple options may be selected; i.e. 8310HP -3+15, which is the standard 8310HP product plus Opt. -3 and Opt. -15 together. Care must be exhibited to not develop conflicting combinations; i.e. 8310HP-3+20.

Option -1: CLOSING CAP. Use to prevent tampering with the set point pressure. Available on all spring chamber materials. Consists of a ductile iron closing cap, a sealing gasket, a sealing lock nut on the adjusting screw, and a 1/4" NPT female tapped spring chamber vent hole.

Option -1+6 And Option -1+8: DIFFERENTIAL CONSTRUCTION – SINGLE DIAPHRAGM, AND DIFFERENTIAL CONSTRUCTION – DOUBLE DIAPHRAGM. Refer to Technical Bulletin 8310-DIFF-TB for 8310HP's utilized in differential pressure service.

Option -3: T-BAR AND LOCKING LEVER. All sizes. Utilized for frequent setpoint changes to range spring.

Option -15: STELLITED SEATS. Stellite seating surfaces on metal seating portions of plug and on both seat rings. See Table 3 for maximum allowable pressure drops.

Option -20: AIR PRESSURE LOADED. No range spring. Incorporates a cast iron or cast steel loading chamber. Use when the outlet pressure is frequently changed. This construction offers the regulators maximum capacity with minimum proportional band "droop" when compared to standard units with a range spring. See Table 1 for capacities. For 10 – 100 psig (.7 – 6.9 Barg) control pressures. **ONLY AVAILABLE ON 8310HP VARIATION; NOT AVAILABLE ON 8310LP.**

Pressures vary in a nearly 1:1 ratio; i.e. 50 psig (3.4 Barg) loading pressure gives nearly a 50 psig (3.4 Barg) outlet pressure.

**TABLE 1
8310HP-20 AIR PRESSURE LOADED
Cv's FOR COMPOSITION & METAL DIAPHRAGMS**

Valve Size		Comp. Diaph. Cv	Metal Diaph. Cv
in	(DN)		
1-1/2"	(40)	26	25
2"	(50)	40	35
2-1/2"	(65)	55	44
3"	(80)	78	54
4"	(100)	100	74

Option -30: INTEGRAL FLANGED END CONNECTIONS. Available with 125# FF and 250# RF flanges for cast iron body material or with 150# RF or 300# RF flanges for cast steel body material.

Option -34: SPECIAL 14" FACE TO FACE DIMENSION FOR FLANGED END CONNECTIONS. CS body material, sizes 1-1/2" & 2" with 150# or 300# RF flanges only. See Opt.-30 for standard face to face dimension.

Option -56: SPECIAL CLEANING. Cleaned per Cashco Specification #S-1542. Utilize when cleanliness level better than normal is required. **NOT** for Oxygen Service.

Option -80: HIGH OUTLET PRESSURE CONSTRUCTION. Utilized for 130 – 200 psig (9.0 – 13.8 Barg) outlet pressure spring range. **ONLY AVAILABLE WITH HP VARIATION**. Special construction includes a diaphragm ring to reduce effective diaphragm area and serve as a travel stop in case of over-pressurization.

Option -95: EPOXY PAINT. Special epoxy painting of all non-corrosion resistant external surfaces per Cashco Spec #S-1547. Utilized in harsh atmospheric conditions.

Option -95OS: EPOXY PAINT. Special epoxy painting of all non-corrosion resistant external surfaces per Cashco Spec #S-1687 for OFFSHORE installations.

TECHNICAL SPECIFICATIONS

TABLE 2
DESIGN PRESSURE-TEMPERATURE MATERIAL LIMITS
 Lower temperature limits will always measure -20 °F (-29 °C)

MATERIAL SPECIFICATIONS		END CONN.	INLET				OUTLET PRESSURE		TEMPERATURE LIMITS OF TRIMS °F (°C)							
			PRESSURE		TEMPERATURE				METAL DIAPHRAGM		COMPOSITION DIAPHRAGM					
DESCRIPTION ABBREV. (BODY/SP.CH.)	ASTM NO.		psig	(Barg)	°F	(°C)	psig	(Barg)	S1 TRIM		S5 TRIM		S40 TRIM			
								°F	(°C)	°F	(°C)	°F	(°C)			
MODEL 8310LP																
Cast Iron (CI/CI)	A126 Class B	125# Flgd.	200	(13.8)	150	(66)	30	(2.1)	450	(232)	300	(149)	180	(83)		
			190	(13.1)	200	(94)										
			175	(12.1)	250	(121)										
			165	(11.4)	300	(149)										
			140	(9.7)	400	(205)										
			125	(8.6)	450	(232)										
		250# Flgd. or NPT	200	(13.8)	450	(232)										
Cast Carbon Steel (CS/CS)	A216 Grade WCB	150# Flgd.	200	(13.8)	400	(205)	30	(2.1)	450	(232)	300	(149)	180	(83)		
			185	(12.8)	450	(232)										
			200	(13.8)	450	(232)										
		300# Flgd. or NPT	200	(13.8)	450	(232)										
MODEL 8310HP																
Cast Iron/ Ductile Iron (CI/DI)	A126 Class B /A395, GR. 60-40-18	125# Flgd.	200	(13.8)	150	(66)	200	(13.8)	150	(66)	150	(66)	150	(66)		
			190	(13.1)	200	(94)										
			175	(12.1)	250	(121)										
			165	(11.4)	300	(149)										
			140	(9.7)	400	(204)										
			125	(8.6)	450	(232)										
				250# Flgd.	375	(25.9)	300	(149)	200	(13.8) & Lower	450	(232)	300	(149)	180	(83)
		335	(23.1)		350	(177)										
		290	(20.0)		400	(205)										
		250	(17.2)		450	(232)										
				NPT	400	(27.6)	150	(66)	200	(13.8) & Lower	450	(232)	300	(149)	180	(83)
		400	(27.6)		200	(94)										
		400	(27.6)		250	(121)										
		375	(25.9)		300	(149)										
		335	(23.1)		350	(177)										
		290	(20.0)		400	(205)										
				150# Flgd.	285	(19.7)	100	(38)	200	(13.8) & Lower	400	(205)	300	(149)	180	(83)
		260	(17.9)		200	(94)										
230	(15.9)	300	(149)													
200	(13.8)	400	(205)													
185	(12.8)	450	(232)													
		300# Flgd. or NPT	650		(44.8)	300	(149)	200								
635	(43.8)		400	(205)												
615	(41.4)		450	(232)												

NOTE: See Table 7 for allowable over pressure limits.

**TABLE 3
MAXIMUM ALLOWABLE PRESSURE DROPS**

Fluid	Max. Recommended Operating Pressure Drop						Option Number	Trim Designation Number
	Model 8310LP		Model 8310HP					
	All Fluid Qualities		Clean Fluid Industrial Quality		Unclean Fluid Pipeline Quality			
	psid	(Bard)	psid	(Bard)	psid	(Bard)		
Non-Cavitating Liquid	150	(10.3)	200	(13.8)	100	(6.9)	None	All
	150	(10.3)	300	(20.7)	150	(10.3)	Stellited Opt-15	
Cavitating Liquids	Consult Factory		Consult Factory		N/R		Stellited Opt-15	S1 Only
Gas	200	(13.8)	450	(31.0)	150	(10.3)	None	All
	200	(13.8)	450	(31.0)	300	(20.7)	Stellited Opt-15	
Steam	150	(10.3)	150	(10.3)	N/R		None	S1 Only
	200	(13.8)	300	(20.7)	150	(10.3)	Stellited Opt-15	

N/R: Not Recommended

**TABLE 4
APPLICATIONS**

Fluid	Recommended Construction	Trim Designation Number
Air or Industrial Gases	Metal Seat & Composition Diaphragm	S40
	Metal Seat & Diaphragm	S1
Chemicals	Metal Seat & Composition Diaphragm	S5, S40
	Metal Seat & Diaphragm	S1
Hydrocarbon Gas or Liquids †	Metal Seat & Composition Diaphragm	S5, S40
	Metal Seat & Diaphragm	S1
Water and Condensate	Metal Seat & Composition Diaphragm	S40
	Metal Seat & Diaphragm	S1
Steam – Saturated or Superheated	Metal Seat & Diaphragm	S1

† In accordance with ASME B31.3 “process piping”, do not use Cast Iron Body for hydrocarbon or flammable fluid service with inlet pressures greater than 150 Psig (10.3 Barg) or temperatures greater than 300° F (149° C).

**TABLE 5
STAINLESS STEEL TRIM MATERIAL COMBINATIONS**

Part	SST Trim Designation Number		
	Metal Diaphragm	Composition Diaphragm	
	S1	S5	S40
Diaphragm	302 SST	Fluorocarbon Elastomer	Neoprene
Plug *	316 SST	316 SST	316 SST
Seat Rings	316 SST	316 SST	316 SST
Stem	316 SST	316 SST	316 SST
Groove Pin	18-8 SST	18-8 SST	18-8 SST
Stem Guides	Hardened 440C SST	Hardened 440C SST	Hardened 440C SST
Bonnet Plug	**	**	**
Pusher Plate	303 SST	303 SST	303 SST
Pusher Plate Nut	Steel	Steel	Steel
Diaphragm Casing O-Ring	TFE	TFE	TFE
Stem Bushing	303 SST	303 SST	303 SST
Bonnet Nut	Steel	Steel	Steel
Needle Valve	Steel	Steel	Steel
Pipe Nipple	Steel	Steel	Steel

* "Plug Assembly" consists of factory-joined plug, stem and groove pin.

** Same as body material.

NOTE: Cashco, Inc. does not recommend metal seated trim on any service where the flow will be dead ended down stream of the pressure reducing regulator. Use different Cashco model such as 1000HP/LP or DA1/DA3/DA4 composition seat for dead end service.

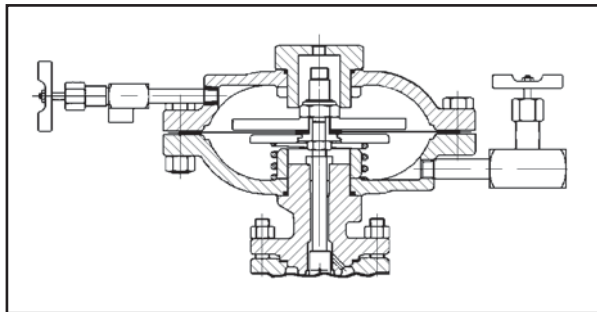

Figure 1
Opt.-20
Air Pressure Loaded

**TABLE 6
STEEL RANGE SPRINGS
METAL OR COMPOSITION DIAPHRAGMS
ALL SIZES**

Construction	Range Spring		
	"LP" Variation	"HP" Variation	
Standard	1-4 *	(.07-.27)	10-40 (.69-2.8)
	3-10	(.21-.69)	30-100 (2.1-6.9)
	8-30	(.55-2.1)	75-145 (5.2-10.0)
Option -80	N/A		130-200 (9.0-13.8)

* Composition Diaphragm Only

N/A: Not Applicable

**TABLE 7
OVER-PRESSURE LIMITS – SAFETY RELIEF VALVE
SIZING & SETPOINT**

Variation	Range Spring		Diaphragm Material	* Emergency Over-Pressure (Rise over Setpoint)		Maximum Cv with Valve Plug Wide Open Body Size - in / (mm)				
	psig	(Barg)		psig	(Barg)	1-1/2" (DN40)	2" (DN50)	2-1/2" (DN65)	3" (DN80)	4" (DN100)
LP	1-4	(.07-.27)	All	20	(1.4)	27	40	55	76	100
	3-10	(.21-.69)								
	8-30	(.55-2.1)								
HP	10-40	(.69-2.8)	All	35	(2.4)	27	40	55	76	100
	30-100	(2.1-6.9)								
	75-145	(5.2-10.0)								
	130-200	(9.0-13.8)								

* Exceeding the "Emergency Over-Pressure" level may cause mechanical damage to internal parts of the valve.

LP VARIATION

TABLE 8
8310LP
CAPACITY TABLES – Cv – METAL DIAPHRAGM

Set Point (Outlet) Pressure, P _s		1-1/2" (DN40) Body			2" (DN50) Body			2-1/2" (DN65) Body			3" (DN80) Body			4" (DN100) Body		
		Droop			Droop			Droop			Droop			Droop		
psig	(Barg)	10%	20%	30%	10%	20%	30%	10%	20%	30%	10%	20%	30%	10%	20%	30%
5	(.34)	8.5	15.1	22.5	10.2	19.7	29.9	12.0	22.9	37.5	13.9	26.1	43.1	19.0	36.1	59.8
*10	(.69)	2.9	5.6	10.0	3.3	6.7	12.0	3.9	7.5	13.2	4.6	8.7	16.0	6.3	12.0	21.7
15	(1.0)	4.2	8.2	12.5	4.8	10.0	16.0	5.5	11.5	18.0	6.8	13.2	21.0	8.1	17.9	28.5
20	(1.4)	6.1	11.5	16.1	7.1	14.1	21.9	8.1	16.5	25.5	9.5	19.0	29.0	13.1	26.4	40.7
25	(1.7)	8.1	14.7	21.7	9.8	18.7	30.1	11.6	22.0	36.0	13.2	25.0	42.4	18.0	30.0	57.5
30	(2.1)	10.9	18.2	23.5	13.2	25.1	32.6	15.5	29.2	41.0	17.9	33.5	46.8	24.5	45.9	65.0

* Utilizes 8 - 30 psig (.55 - 2.1 Barg) range spring

TABLE 9
8310LP
CAPACITY TABLES – Cv – COMPOSITION DIAPHRAGM

Set Point (Outlet) Pressure, P _s		1-1/2" (DN40) Body			2" (DN50) Body			2-1/2" (DN65) Body			3" (DN80) Body			4" (DN100) Body		
		Droop			Droop			Droop			Droop			Droop		
psig	(Barg)	10%	20%	30%	10%	20%	30%	10%	20%	30%	10%	20%	30%	10%	20%	30%
2	(.14)	16.8	25.7	26.2	22.0	35.9	39.3	25.3	46.2	52.8	29.0	58.4	73.2	40.5	81.2	99.0
5	(.34)	14.0	23.6	26.2	18.0	32.9	38.0	21.1	41.2	50.0	24.0	47.7	67.0	33.1	66.5	94.4
*10	(.69)	5.5	10.8	15.5	6.3	13.0	20.0	7.8	15.3	22.7	8.8	27.4	26.4	12.2	23.9	36.5
15	(1.0)	7.5	14.0	20.0	8.9	18.0	37.3	10.5	21.2	32.3	12.2	24.2	36.8	16.9	33.2	50.7
20	(1.4)	10.0	17.8	23.7	12.2	23.8	33.1	13.8	27.8	41.9	16.2	32.2	48.8	22.2	44.3	67.9
25	(1.7)	13.3	22.3	26.2	16.9	31.2	37.2	19.7	37.8	48.3	22.5	43.7	53.7	31.2	60.3	90.5
30	(2.1)	17.5	25.8	26.2	23.5	36.5	39.3	27.2	47.3	53.6	31.7	61.3	75.0	43.3	86.1	99.8

* Utilizes 8 - 30 psig (.55 - 2.1 Barg) range spring

HP VARIATION

TABLE 10
8310HP
CAPACITY TABLES – Cv – METAL DIAPHRAGM

Set Point (Outlet) Pressure, P _s		1-1/2" (DN40) Body			2" (DN50) Body			2-1/2" (DN65) Body			3" (DN80) Body			4" (DN100) Body		
		Droop			Droop			Droop			Droop			Droop		
psig	(Barg)	10%	20%	30%	10%	20%	30%	10%	20%	30%	10%	20%	30%	10%	20%	30%
10	(.69)	2.0	4.2	7.5	2.6	6.3	9.0	3.0	6.8	10.5	4.0	7.5	12.0	5.0	11.0	16.7
15	(1.0)	3.0	8.0	12.0	4.0	9.2	14.5	5.0	11.2	16.5	6.0	12.5	19.0	8.5	17.5	23.5
25	(1.7)	7.5	14.0	19.0	8.7	18.0	26.5	10.0	21.0	31.3	11.7	23.7	36.5	18.5	32.5	48.0
35	(2.4)	11.5	19.7	25.2	14.0	27.5	35.7	16.5	32.3	45.7	18.7	37.2	55.7	26.5	51.5	78.7
50	(3.4)	6.2	11.7	16.7	7.3	14.8	22.0	8.0	16.8	25.2	9.5	19.0	28.7	13.0	26.8	39.5
75	(5.2)	8.5	15.5	21.0	10.0	20.3	29.0	11.2	23.5	35.0	13.0	27.0	40.5	18.0	36.5	55.7
100	(6.9)	8.7	18.0	21.2	10.5	21.0	29.5	12.0	23.8	36.0	13.7	27.2	41.3	18.7	37.5	56.5
140	(9.7)	10.8	18.5	24.0	12.5	25.0	33.5	15.0	28.8	43.0	17.0	32.5	51.3	23.5	44.7	71.0
150	(10.3)	11.4	19.5	25.0	13.8	27.1	35.5	16.2	31.9	45.0	18.5	36.3	55.5	25.0	50.7	76.5
200	(13.8)	14.0	23.5	26.0	18.7	33.4	38.5	21.2	41.3	50.2	24.4	48.5	67.5	33.7	67.5	95.0

TABLE 11
8310HP
CAPACITY TABLES – Cv – COMPOSITION DIAPHRAGM

Set Point (Outlet) Pressure, P _s		1-1/2" (DN40) Body			2" (DN50) Body			2-1/2" (DN65) Body			3" (DN80) Body			4" DN100) Body		
		Droop			Droop			Droop			Droop			Droop		
psig	(Barg)	10%	20%	30%	10%	20%	30%	10%	20%	30%	10%	20%	30%	10%	20%	30%
10	(.69)	6.0	11.2	16.2	7.0	14.0	21.5	8.0	16.2	24.8	9.2	18.7	28.7	13.0	26.2	39.1
15	(1.0)	7.5	13.8	19.5	9.1	18.7	27.2	11.2	21.2	32.1	12.5	24.1	36.5	17.0	33.5	50.8
25	(1.7)	10.5	19.0	25.0	13.0	26.3	34.8	15.0	31.0	44.3	17.6	35.5	53.5	24.0	48.8	73.7
35	(2.4)	16.0	25.4	26.2	21.4	35.7	39.0	24.5	45.7	52.4	28.1	56.5	72.2	38.8	78.7	98.2
50	(3.4)	10.5	18.7	24.5	13.0	26.1	34.2	15.0	30.0	43.7	17.4	34.8	52.1	24.0	47.5	72.2
75	(5.2)	15.2	24.7	26.2	20.2	34.7	38.7	22.9	43.7	51.2	26.5	52.8	70.0	36.7	72.8	97.5
100	(6.9)	12.1	21.3	26.0	15.7	29.4	36.9	17.7	36.0	47.5	20.4	41.2	61.3	28.0	57.0	86.0
140	(9.7)	16.5	26.0	26.0	22.4	38.0	37.0	26.0	50.0	52.5	30.0	67.0	72.0	41.5	95.0	97.0
150	(10.3)	17.8	26.2	26.2	24.4	37.0	39.3	28.0	37.9	53.8	32.4	62.5	75.2	44.2	88.5	100.0
200	(13.8)	21.2	26.2	26.2	29.1	38.8	39.5	35.1	51.5	55.0	40.2	70.8	78.0	55.1	97.5	100.0

METRIC CONVERSION FACTORS: Cv ÷ 1.16 = kv

TABLE 12
MODEL 8310 – “HP VARIATION”
WATER CAPACITY – GPM
S.G. = 1.0 T = 60°F F_L = 0.88

ALL Sizes – Composition Diaphragm Only

Set Point Pressure - P2		Inlet Pressure		1-1/2" (DN40) Body			2" (DN50) Body			2-1/2" (DN65) Body			3" (DN80) Body			4" (DN100) Body		
				Droop			Droop			Droop			Droop			Droop		
psig	(Barg)	psig	(Barg)	10%	20%	30%	10%	20%	30%	10%	20%	30%	10%	20%	30%	10%	20%	30%
10	(0.69)	50	(3.4)	37.9	70.8	102.5	44.3	88.5	136	50.6	102.5	156.8	58.2	118.3	181.5	82.2	165.7	247.3
		75	(5.2)	48.4	90.3	130.6	56.4	112.9	173.3	64.5	130.6	199.9	74.2	150.8	231.4	104.8	211.2	315.2
		100	(6.9)	CAV	CAV	CAV	CAV	CAV	CAV	CAV	CAV	CAV	CAV	CAV	CAV	CAV	CAV	CAV
15	(1.0)	50	(3.4)	44.4	81.6	115.4	53.8	110.6	160.9	66.3	125.4	189.9	74.0	142.6	215.9	100.6	198.2	300.5
		75	(5.2)	58.1	106.9	151.0	70.5	144.8	210.7	86.8	164.2	248.6	96.8	186.7	282.7	131.7	259.5	393.5
		100	(6.9)	69.1	127.2	HI VEL	83.9	172.4	250.8	103.3	195.5	295.9	115.2	222.2	336.5	156.7	308.9	468.4
		125	(8.6)	CAV	CAV	CAV	CAV	CAV	CAV	CAV	CAV	CAV	CAV	CAV	CAV	CAV	CAV	CAV
25	(1.7)	50	(3.4)	52.5	95.0	125.0	65.0	131.5	174.0	75.0	155.0	221.5	88.0	177.5	267.5	120.0	244.0	368.5
		75	(5.2)	74.2	134.4	HI VEL	91.9	186.0	246.1	106.1	219.2	313.2	124.5	251.0	378.3	169.7	345.1	521.1
		100	(6.9)	90.9	HI VEL	HI VEL	112.6	227.8	HI VEL	129.9	268.5	383.6	152.4	307.4	463.3	207.8	422.6	638.3
		125	(8.6)	105.0	HI VEL	HI VEL	130.0	263.0	HI VEL	150.0	310.0	HI VEL	176.0	355.0	535.0	240.0	488.0	737.0
		150	(10.3)	117.4	HI VEL	HI VEL	145.3	HI VEL	HI VEL	167.7	346.6	HI VEL	196.8	396.9	598.1	268.3	545.6	824.0
		175	(12.1)	CAV	CAV	CAV	CAV	CAV	CAV	CAV	CAV	CAV	CAV	CAV	CAV	CAV	CAV	CAV
35	(2.4)	50	(3.4)	62.0	98.4	101.5	82.9	138.3	151.0	94.9	177.0	202.9	108.8	218.8	279.6	150.3	304.8	380.3
		75	(5.2)	101.2	HI VEL	HI VEL	135.3	225.8	246.7	155.0	289.0	331.4	177.7	357.3	456.6	245.4	497.7	621.1
		100	(6.9)	129.0	HI VEL	HI VEL	172.5	HI VEL	HI VEL	197.5	368.4	422.5	226.5	455.5	582.1	312.8	634.5	791.7
		125	(8.6)	151.8	HI VEL	HI VEL	203.0	HI VEL	HI VEL	232.4	HI VEL	HI VEL	266.6	536.0	684.9	368.1	746.6	931.6
		150	(10.3)	HI VEL	HI VEL	HI VEL	229.5	HI VEL	HI VEL	262.7	HI VEL	HI VEL	301.3	605.9	HI VEL	416.1	844.0	1053.1
		175	(12.1)	HI VEL	HI VEL	HI VEL	253.2	HI VEL	HI VEL	289.9	HI VEL	HI VEL	332.5	668.5	HI VEL	459.1	931.2	1161.9
		200	(13.8)	HI VEL	HI VEL	HI VEL	274.9	HI VEL	HI VEL	314.7	HI VEL	HI VEL	361.0	HI VEL	HI VEL	498.4	1010.9	1261.4
		250	(17.2)	CAV	CAV	CAV	CAV	CAV	CAV	CAV	CAV	CAV	CAV	CAV	CAV	CAV	CAV	CAV
50	(3.4)	75	(5.2)	52.5	93.5	122.5	65.0	130.5	171.0	75.0	150.0	218.5	87.0	174.0	260.5	120.0	237.5	361.0
		100	(6.9)	74.2	132.2	HI VEL	91.9	184.6	241.8	106.1	212.1	309.0	123.0	246.1	368.4	169.7	335.9	510.5
		125	(8.6)	90.9	HI VEL	HI VEL	112.6	226.0	HI VEL	129.9	259.8	378.5	150.7	301.4	451.2	207.8	411.4	625.3
		150	(10.3)	105.0	HI VEL	HI VEL	130.0	261.0	HI VEL	150.0	300.0	HI VEL	174.0	348.0	521.0	240.0	475.0	722.0
		175	(12.1)	117.4	HI VEL	HI VEL	145.3	HI VEL	HI VEL	167.7	335.4	HI VEL	194.5	389.1	582.5	268.3	531.1	807.2
		200	(13.8)	128.6	HI VEL	HI VEL	159.2	HI VEL	HI VEL	183.7	367.4	HI VEL	213.1	426.2	638.1	293.9	581.8	884.3
		250	(17.2)	148.5	HI VEL	HI VEL	183.8	HI VEL	HI VEL	212.1	424.3	HI VEL	246.1	492.1	HI VEL	339.4	671.8	1021.1
		300	(20.7)	CAV	CAV	CAV	CAV	CAV	CAV	CAV	CAV	CAV	CAV	CAV	CAV	CAV	CAV	CAV
75	(5.2)	100	(6.9)	76.0	123.5	131.0	101.0	173.5	193.5	114.5	218.5	256.0	132.5	264.0	350.0	183.5	364.0	487.5
		125	(8.6)	107.5	HI VEL	HI VEL	142.8	245.4	273.7	161.9	309.0	362.0	187.4	373.4	495.0	259.5	514.8	689.4
		150	(10.3)	131.6	HI VEL	HI VEL	174.9	HI VEL	HI VEL	198.3	378.5	HI VEL	229.5	457.3	606.2	317.8	630.5	844.4
		175	(12.1)	152.0	HI VEL	HI VEL	202.0	HI VEL	HI VEL	229.0	HI VEL	HI VEL	265.0	528.0	700.0	367.0	728.0	975.0
		200	(13.8)	HI VEL	HI VEL	HI VEL	225.8	HI VEL	HI VEL	256.0	HI VEL	HI VEL	296.3	590.3	HI VEL	410.3	813.9	1090.1
		250	(17.2)	HI VEL	HI VEL	HI VEL	267.2	HI VEL	HI VEL	302.9	HI VEL	HI VEL	350.6	698.5	HI VEL	485.5	963.1	1289.8
100	(6.9)	300	(20.7)	HI VEL	HI VEL	HI VEL	HI VEL	HI VEL	343.5	HI VEL	HI VEL	397.5	HI VEL	HI VEL	550.5	1092	HI VEL	
		125	(8.6)	60.5	106.5	130.0	78.5	147.0	184.5	88.5	180.0	237.5	102.0	206.0	306.5	140.0	285.0	430.0
		150	(10.3)	85.6	150.6	HI VEL	111.0	207.9	260.9	125.2	254.6	335.9	144.2	291.3	433.5	198.0	403.1	608.1
		175	(12.1)	104.8	HI VEL	HI VEL	136.0	254.6	HI VEL	153.3	311.8	411.4	176.7	356.8	530.9	242.5	493.6	744.8
		200	(13.8)	121.0	HI VEL	HI VEL	157.0	HI VEL	HI VEL	177.0	360.0	HI VEL	204.0	412.0	613.0	280.0	570.0	860.0
140	(9.7)	250	(17.2)	148.2	HI VEL	HI VEL	192.3	HI VEL	HI VEL	216.8	HI VEL	HI VEL	249.8	504.6	HI VEL	342.9	698.1	1053.3
		300	(20.7)	HI VEL	HI VEL	HI VEL	222.0	HI VEL	HI VEL	250.3	HI VEL	HI VEL	288.5	582.7	HI VEL	396.0	806.1	1216.2
		150	(10.3)	52.2	82.2	82.2	70.8	120.2	117.0	82.2	158.1	166.0	94.9	211.9	227.7	131.2	300.4	306.7
		175	(12.1)	97.6	153.8	153.8	132.5	224.8	218.9	153.8	295.8	310.6	177.5	396.4	426.0	245.5	562.0	573.9
150	(10.3)	200	(13.8)	127.8	HI VEL	HI VEL	173.5	HI VEL	HI VEL	201.4	387.3	406.7	232.4	519.0	557.7	321.5	735.9	751.4
		250	(17.2)	HI VEL	HI VEL	HI VEL	234.9	HI VEL	HI VEL	272.7	HI VEL	HI VEL	314.6	702.7	HI VEL	435.3	996.4	1017.3
		300	(20.7)	HI VEL	HI VEL	HI VEL	HI VEL	HI VEL	HI VEL	328.9	HI VEL	HI VEL	379.5	HI VEL	HI VEL	524.9	1201.7	1227.0
		175	(12.1)	89.0	131.0	131.0	122.0	185.0	196.5	140.0	189.5	269.0	162.0	312.5	376.0	221.0	442.5	500.0
200	(13.8)	200	(13.8)	125.9	HI VEL	HI VEL	172.5	261.6	277.9	198.0	268.0	380.4	229.1	441.9	531.7	312.5	625.8	707.1
		250	(17.2)	HI VEL	HI VEL	HI VEL	244.0	HI VEL	HI VEL	280.0	379.0	HI VEL	324.0	625.0	HI VEL	442.0	885.0	1000
		300	(20.7)	HI VEL	HI VEL	HI VEL	HI VEL	HI VEL	HI VEL	342.9	HI VEL	HI VEL	396.8	HI VEL	HI VEL	541.3	1083.9	1224.7
200	(13.8)	250	(17.2)	149.9	HI VEL	HI VEL	205.8	274.4	279.3	248.2	364.2	388.9	284.3	500.6	551.5	389.6	689.4	707.1
		300	(20.7)	HI VEL	HI VEL	HI VEL	HI VEL	HI VEL	HI VEL	351.0	HI VEL	HI VEL	402.0	708.0	HI VEL	551.0	975.0	1000

NOTE: Where “CAV” is indicated within the above capacity tables, the water has reached full cavitation, and flow is choked.
Where “HI VEL” is indicated, the flow has reached or exceeded the velocities to the right based on Schedule 40 pipe.

METRIC CONVERSION FACTOR: GPM x 3.785 = LPM

SIZE		MAX. VEL
in	(DN)	
1-1/2"	(40)	25 fps
2"	(50)	27 fps
2-1/2"	(65)	29 fps
3"	(80)	31 fps
4"	(100)	35 fps

TABLE 15
MODEL 8310 - "LP VARIATION"
AIR CAPACITY - SCFH
S.G. = 1.0 T = 60°F F_L = 0.88

All Sizes - Composition Diaphragm Only

Set Point Pressure - P2		Inlet Pressure		1-1/2" (DN40) Body			2" (DN50) Body			2-1/2" (DN65) Body			3" (DN80) Body			4" (DN100) Body		
				Droop			Droop			Droop			Droop			Droop		
psig	(Barg)	psig	(Barg)	10%	20%	30%	10%	20%	30%	10%	20%	30%	10%	20%	30%	10%	20%	30%
2	(.14)	25	(1.7)	21400	32700	33400	28000	45700	50000	32200	58800	67200	36900	74300	93200	51600	103400	126000
		50	(3.4)	34900	53300	54400	45600	74500	81500	52500	95900	109500	60200	121200	151900	84000	168500	205400
		75	(5.2)	48300	SONIC	SONIC	63300	103300	SONIC	72800	132900	151900	83400	168000	210600	116500	233600	284800
		100	(6.9)	61800	SONIC	SONIC	80900	SONIC	SONIC	93100	SONIC	SONIC	106700	214800	SONIC	149000	298700	364100
		125	(8.6)	SONIC	SONIC	SONIC	98600	SONIC	SONIC	113300	SONIC	SONIC	129900	SONIC	SONIC	181400	363800	SONIC
		150	(10.3)	SONIC	SONIC	SONIC	SONIC	SONIC	133600	SONIC	SONIC	153200	SONIC	SONIC	213900	SONIC	SONIC	
5	(.34)	25	(1.7)	17800	30000	33400	22900	41900	48400	26900	52500	63700	30600	60700	75300	42100	84700	120200
		50	(3.4)	29000	49000	54400	37300	68300	78800	43800	85500	103700	49800	99000	139000	68700	138000	195900
		75	(5.2)	40300	67900	75400	51800	94600	109300	60700	118500	143800	69000	137200	192700	95200	191300	271500
		100	(6.9)	51500	SONIC	SONIC	66200	121000	SONIC	77600	151500	SONIC	88300	175400	246400	121700	244600	347200
		125	(8.6)	62700	SONIC	SONIC	80600	SONIC	SONIC	94500	SONIC	SONIC	107500	213700	SONIC	148300	297900	422900
		150	(10.3)	73900	SONIC	SONIC	95100	SONIC	SONIC	111400	SONIC	SONIC	126800	251900	SONIC	174800	351200	SONIC
10	(.69)	25	(1.7)	7000	13700	19700	8000	16500	25400	9900	19400	28800	11200	34800	33500	15500	30400	46400
		50	(3.4)	11400	22400	32200	13100	27000	41500	16200	31700	47100	18300	56800	54800	25300	49600	75700
		75	(5.2)	15800	31100	44600	18100	37400	57500	22400	44000	65300	25300	78800	75900	35100	68700	105000
		100	(6.9)	20200	39700	57000	23200	47800	73600	28700	56300	83500	32400	100800	97100	44900	87900	134300
		125	(8.6)	24600	48400	69400	28200	58200	89600	34900	68500	101700	39400	122700	118300	54700	107100	163500
		150	(10.3)	29000	57000	81900	33300	68700	105600	41200	80800	119900	46500	144700	139400	64400	126200	192800
15	(1.0)	25	(1.7)	8900	16700	23800	10600	21400	34400	12500	25200	38500	14500	28800	43800	20100	39500	60400
		50	(3.4)	15600	29000	41500	18500	37300	57400	21800	44000	67000	25300	50200	76400	35100	68900	105200
		75	(5.2)	21600	40300	57500	25600	51800	107300	30200	61000	92900	35100	69600	105900	48600	95500	145800
		100	(6.9)	27600	51500	73600	32700	66200	137200	38600	78000	118800	44900	89000	135400	62200	122100	186500
		125	(8.6)	33600	62700	89600	39900	80600	167100	47000	95000	144700	54700	108400	164900	75700	148700	227100
		150	(10.3)	39600	73900	105600	47000	95100	SONIC	55500	112000	170600	64400	127800	194400	89300	175300	267800
20	(1.4)	25	(1.7)	9500	26400	22500	11600	22600	31500	13100	26400	39800	15400	30600	46400	21100	42100	64500
		50	(3.4)	20700	57500	49100	25300	49300	68500	28600	57500	86700	33500	66700	101000	46000	91700	140600
		75	(5.2)	28800	80000	68200	35100	68500	95200	39700	80000	120500	46600	92600	140400	63900	127400	195300
		100	(6.9)	36800	102300	87200	44900	87500	121700	50800	102300	154100	59600	118400	179500	81700	162900	249700
		125	(8.6)	44800	124500	106200	54700	106600	148300	61800	124500	187700	72600	144300	218600	99500	198500	304200
		150	(10.3)	52800	SONIC	125200	64400	125700	174800	72900	146800	221300	85600	170100	257700	117300	234000	358600
25	(1.7)	50	(3.4)	27000	45300	53200	34300	63300	75500	40000	76700	98000	45700	88700	109000	63300	122400	183700
		75	(5.2)	38300	64100	75400	48600	89700	107000	56700	108700	138900	64700	125700	154500	89700	173500	260300
		100	(6.9)	48900	82000	96400	62200	114800	136800	72500	139000	177700	82800	160700	197500	114800	221800	332900
		125	(8.6)	59600	99900	117400	75700	139800	166700	88300	169300	216400	100800	195800	240600	139800	270100	405400
		150	(10.3)	70200	117800	138400	89300	164800	196500	104000	199600	255100	118800	230800	283600	164800	318500	478000
30	(2.1)	50	(3.4)	34000	50100	50800	45600	70800	76300	52800	91800	104000	61500	118900	145500	84000	167100	193600
		75	(5.2)	50200	74000	75200	67400	104700	112800	78100	135700	153800	91000	175900	215200	124300	247100	286400
		100	(6.9)	64400	94900	96400	86400	134300	144600	100000	174000	197200	116600	225500	275900	159300	316700	367100
		125	(8.6)	78400	115600	117400	105300	163500	176100	121900	211900	240100	142000	274600	336000	194000	385700	447100
		150	(10.3)	92400	136300	138400	124100	192800	207600	143700	249800	283100	167400	323800	396100	228700	454700	527100

NOTE: Where "SONIC" is indicated within the above capacity tables, outlet velocity with Schedule 40 pipe has reached sonic velocity of 1118 fps. Additional flow cannot be obtained, and pipeline velocity is in excess of customary pipe velocity design limits. Flow will be approximately the last indicated value in the column above "SONIC".

METRIC CONVERSION FACTORS: SCFH ÷ 35.31 = Sm³/HR
 SCFH ÷ 37.32 = Nm³/HR

TABLE 16
MODEL 8310 - "LP VARIATION"
STEAM CAPACITY - LBS/HR
S.G. = Actual T = Saturated F_L = 0.88
All Sizes - Metal Diaphragm

Set Point Pressure - P2		Inlet Pressure		1-1/2" (DN40) Body			2" (DN50) Body			2-1/2" (DN65) Body			3" (DN80) Body			4" (DN100) Body		
psig	(Barg)	psig	(Barg)	Droop			Droop			Droop			Droop			Droop		
				10%	20%	30%	10%	20%	30%	10%	20%	30%	10%	20%	30%	10%	20%	30%
5	(0.34)	10	(.69)	262	466	694	315	608	922	370	706	1156	429	805	1329	586	1113	1844
		25	(1.7)	539	957	1425	646	1248	1894	760	1451	2376	881	1654	2731	1204	2287	3789
		50	(3.4)	897	HI VEL	HI VEL	1076	2078	HI VEL	1266	2416	HI VEL	1466	2753	4546	2004	3808	6308
		75	(5.2)	1231	HI VEL	HI VEL	1477	HI VEL	HI VEL	1738	3317	HI VEL	2013	3780	HI VEL	2752	5229	8661
		100	(6.9)	HI VEL	HI VEL	HI VEL	1879	HI VEL	HI VEL	2210	HI VEL	HI VEL	2560	4807	HI VEL	3500	6649	HI VEL
		125	(8.6)	HI VEL	HI VEL	HI VEL	2276	HI VEL	HI VEL	2678	HI VEL	HI VEL	3102	HI VEL	HI VEL	4240	8057	HI VEL
		150	(10.3)	HI VEL	HI VEL	HI VEL	HI VEL	HI VEL	HI VEL	3142	HI VEL	HI VEL	3639	HI VEL	HI VEL	4974	9451	HI VEL
		175	(12.1)	HI VEL	HI VEL	HI VEL	HI VEL	HI VEL	HI VEL	HI VEL	HI VEL	HI VEL	4181	HI VEL	HI VEL	5715	HI VEL	HI VEL
		200	(13.8)	HI VEL	HI VEL	HI VEL	HI VEL	HI VEL	HI VEL	HI VEL	HI VEL	HI VEL	4667	HI VEL	HI VEL	6379	HI VEL	HI VEL
		250	(17.2)	HI VEL	HI VEL	HI VEL	HI VEL	HI VEL	HI VEL	HI VEL	HI VEL	HI VEL	HI VEL	HI VEL	HI VEL	7930	HI VEL	HI VEL
300	(20.7)	HI VEL	HI VEL	HI VEL	HI VEL	HI VEL	HI VEL	HI VEL	HI VEL	HI VEL	HI VEL	HI VEL	HI VEL	9411	HI VEL	HI VEL		
10	(0.69)	25	(1.7)	174	336	601	198	402	721	234	451	793	276	523	961	378	721	1304
		50	(3.4)	300	579	1034	341	693	1241	403	776	1365	476	900	1655	652	1241	2244
		75	(5.2)	420	811	1448	478	970	1738	565	1086	1912	666	1260	2317	912	1738	3143
		100	(6.9)	534	1031	1842	608	1234	2210	718	1381	2431	847	1602	2947	1160	2210	3997
		125	(8.6)	647	1250	HI VEL	736	1495	2678	870	1674	2946	1027	1942	3571	1406	2678	4843
		150	(10.3)	759	1466	HI VEL	864	1754	3142	1021	1964	3456	1204	2278	4189	1649	3142	5681
		175	(12.1)	872	1684	HI VEL	993	2015	HI VEL	1173	2256	3970	1384	2617	4813	1895	3609	6527
		200	(13.8)	974	1880	HI VEL	1108	2250	HI VEL	1309	2518	HI VEL	1544	2921	5372	2115	4029	7286
		250	(17.2)	1210	HI VEL	HI VEL	1377	2796	HI VEL	1628	3130	HI VEL	1920	3631	6678	2629	5008	9057
		300	(20.7)	1436	HI VEL	HI VEL	1635	HI VEL	HI VEL	1932	3715	HI VEL	2278	4309	HI VEL	3120	5944	10748
15	(1.0)	25	(1.7)	224	437	666	256	533	853	293	613	959	362	704	1119	432	954	1519
		50	(3.4)	429	838	1278	491	1022	1635	562	1175	1840	695	1349	2146	828	1829	2913
		75	(5.2)	608	1188	1811	695	1448	2317	797	1666	2607	985	1912	3042	1173	2593	4128
		100	(6.9)	774	1510	2302	884	1842	2947	1013	2118	3315	1252	2431	3868	1492	3297	5249
		125	(8.6)	937	1830	HI VEL	1071	2232	3571	1227	2567	4017	1518	2946	4687	1808	3995	6361
		150	(10.3)	1100	2147	HI VEL	1257	2618	HI VEL	1440	3011	4712	1780	3456	5498	2121	4686	7461
		175	(12.1)	1263	HI VEL	HI VEL	1444	3008	HI VEL	1654	3459	HI VEL	2045	3970	6317	2436	5384	8572
		200	(13.8)	1410	HI VEL	HI VEL	1612	3358	HI VEL	1847	3861	HI VEL	2283	4432	7051	2720	6010	9569
		250	(17.2)	1753	HI VEL	HI VEL	2003	HI VEL	HI VEL	2295	4800	HI VEL	2838	5509	HI VEL	3381	7471	11895
		300	(20.7)	2080	HI VEL	HI VEL	2378	HI VEL	HI VEL	2724	HI VEL	HI VEL	3368	6538	HI VEL	4012	8866	14116
20	(1.4)	25	(1.7)	248	468	655	289	574	891	330	671	1038	387	773	1180	533	1074	1656
		50	(3.4)	612	1153	1615	712	1414	2196	812	1655	2557	953	1905	2908	1314	2648	4082
		75	(5.2)	863	1626	2277	1004	1994	3097	1146	2334	3606	1344	2687	4101	1853	3734	5756
		100	(6.9)	1124	2118	HI VEL	1308	2597	4034	1492	3039	4697	1750	3500	5342	2413	4863	7497
		125	(8.6)	1361	2567	HI VEL	1585	3147	HI VEL	1808	3682	5691	2120	4240	6472	2924	5892	9083
		150	(10.3)	1597	HI VEL	HI VEL	1859	3691	HI VEL	2121	4320	HI VEL	2487	4974	7592	3430	6912	10655
		175	(12.1)	1835	HI VEL	HI VEL	2136	4241	HI VEL	2436	4963	HI VEL	2857	5715	8723	3940	7941	12242
		200	(13.8)	2048	HI VEL	HI VEL	2384	HI VEL	HI VEL	2720	5540	HI VEL	3190	6379	HI VEL	4398	8864	13665
		250	(17.2)	2546	HI VEL	HI VEL	2963	HI VEL	HI VEL	3381	HI VEL	HI VEL	3965	7930	HI VEL	5467	11018	HI VEL
		300	(20.7)	HI VEL	HI VEL	HI VEL	3517	HI VEL	HI VEL	4012	HI VEL	HI VEL	4705	9411	HI VEL	6489	13076	HI VEL
25	(1.7)	50	(3.4)	783	1422	2099	948	1809	2911	1122	2128	3482	1277	2418	4101	1741	2902	5561
		75	(5.2)	1139	2067	HI VEL	1378	2630	4233	1631	3094	5063	1856	3516	5963	2531	4219	8087
		100	(6.9)	1492	2708	HI VEL	1805	3444	HI VEL	2137	4052	6631	2431	4605	7810	3315	5526	10591
		125	(8.6)	1808	HI VEL	HI VEL	2187	4173	HI VEL	2589	4910	HI VEL	2946	5580	9463	4017	6695	12833
		150	(10.3)	2121	HI VEL	HI VEL	2566	4896	HI VEL	3037	5760	HI VEL	3456	6545	11101	4712	7854	15054
		175	(12.1)	2436	HI VEL	HI VEL	2948	HI VEL	HI VEL	3489	6617	HI VEL	3970	7520	HI VEL	5414	9024	17295
		200	(13.8)	2720	HI VEL	HI VEL	3290	HI VEL	HI VEL	3895	HI VEL	HI VEL	4432	8394	HI VEL	6044	10073	HI VEL
		250	(17.2)	HI VEL	HI VEL	HI VEL	4090	HI VEL	HI VEL	4841	HI VEL	HI VEL	5509	10434	HI VEL	7512	12521	HI VEL
		300	(20.7)	HI VEL	HI VEL	HI VEL	4854	HI VEL	HI VEL	5746	HI VEL	HI VEL	6538	HI VEL	HI VEL	8916	14859	HI VEL
		30	(2.1)	50	(3.4)	993	1659	2142	1203	2287	2971	1413	2661	3737	1631	3053	4265	2233
75	(5.2)	1518		2534	3273	1838	3495	4540	2158	4066	5710	2493	4665	6517	3412	6392	9052	
100	(6.9)	1956		3266	HI VEL	2368	4504	HI VEL	2781	5239	7357	3212	6011	8397	4396	8236	11663	
125	(8.6)	2433		HI VEL	HI VEL	2946	5602	HI VEL	3459	6517	HI VEL	3995	7477	10445	5468	10244	14507	
150	(10.3)	2854		HI VEL	HI VEL	3456	HI VEL	HI VEL	4058	7645	HI VEL	4686	8770	12252	6414	12017	17017	
175	(12.1)	3279		HI VEL	HI VEL	3970	HI VEL	HI VEL	4662	HI VEL	HI VEL	5384	10076	HI VEL	7369	13806	19551	
200	(13.8)	HI VEL		HI VEL	HI VEL	4432	HI VEL	HI VEL	5204	HI VEL	HI VEL	6010	11248	HI VEL	8226	15411	HI VEL	
250	(17.2)	HI VEL		HI VEL	HI VEL	5509	HI VEL	HI VEL	6469	HI VEL	HI VEL	7471	HI VEL	HI VEL	10225	19157	HI VEL	
300	(20.7)	HI VEL	HI VEL	HI VEL	HI VEL	HI VEL	HI VEL	7677	HI VEL	HI VEL	8866	HI VEL	HI VEL	12135	HI VEL	HI VEL		

NOTE: Where "HI VEL" is indicated, the flow has reached or exceeded a velocity of Mach 0.35, an accepted limit for expanded steam on the downstream side. Use of higher velocities normally generate excessive noise levels.

METRIC CONVERSION FACTOR: LBS/HR x 0.4536 = KG/HR

DIMENSIONS AND WEIGHTS – ENGLISH UNITS

Size Inches	End Conn	Dimensions - inches											Approximate Ship Weight lbs.	
		A	B	C		D	E	F	G	H	I	J	"LP"	"HP"
				"LP"	"HP"									
1-1/2" *	NPT	3.69	8.00	14.00	11.25	4.75	6.89	11.12	20.25	20.50	8.00	9.81	121	100
	125/150# Flgd.	4.06	8.75										127	106
	250/300# Flgd.	4.31	9.25										135	114
2" **	NPT	4.25	9.26	14.00	11.25	6.38	8.44	12.69	21.50	22.00	10.94	12.75	161	140
	125/150# Flgd.	4.62	10.00										173	152
	250/300# Flgd.	4.88	10.50										177	156
2-1/2"	125/150# Flgd.	5.06	10.88	14.00	11.25	6.38	8.44	12.69	21.50	22.00	10.94	12.75	201	180
	250/300# Flgd.	5.38	11.50										206	185
3"	125/150# Flgd.	5.50	11.75	14.00	11.25	7.69	9.74	14.00	22.75	23.50	11.25	13.06	226	205
	250/300# Flgd.	5.88	12.50										234	213
4"	125/150# Flgd.	6.56	13.88	14.00	11.25	7.69	9.74	14.00	22.75	23.50	11.25	13.06	251	230
	250/300# Flgd.	6.88	14.50										269	248

* 1-1/2" Size CS body material with Opt-34: "A" dim. = 7.31" & "B" dim = 14.00"
 ** 2" Size CS body material with Opt-34: "A" dim. = 7.38" & "B" dim = 14.00"

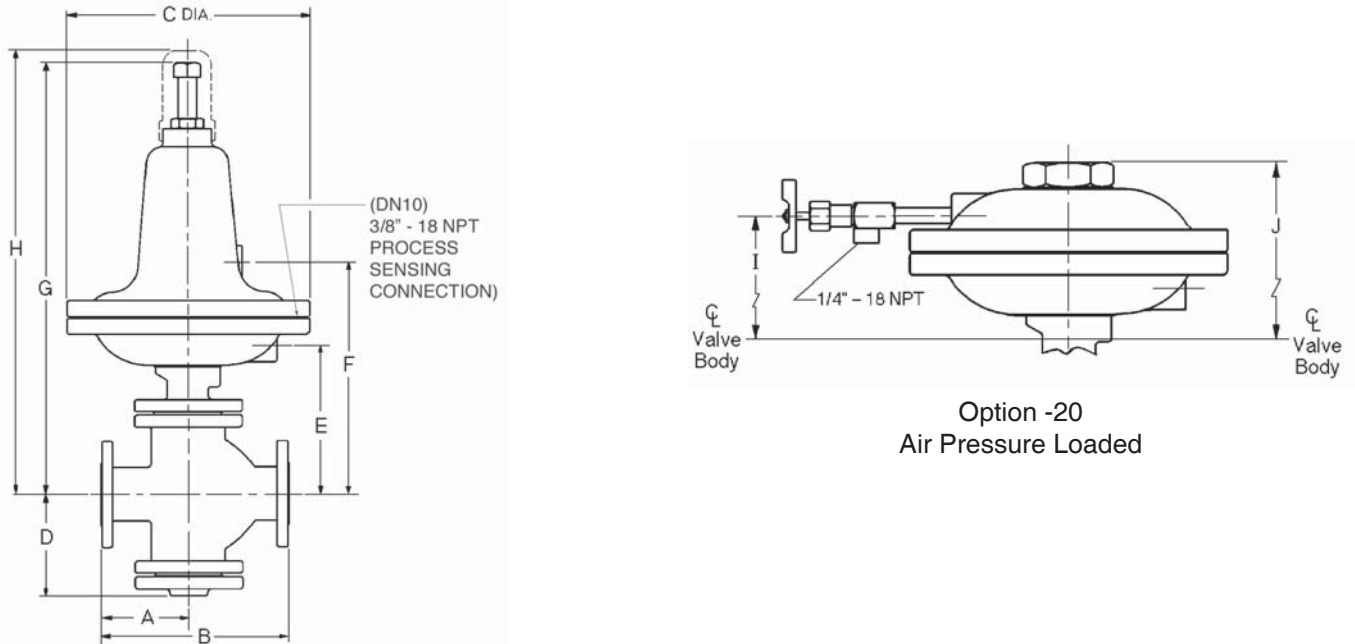

DIMENSIONS AND WEIGHTS – METRIC UNITS

Size (DN)	End Conn	Dimensions (mm)											Approximate Ship Weight (kg)	
		A	B	C		D	E	F	G	H	I	J	"LP"	"HP"
				"LP"	"HP"									
(40) *	NPT	94	203	356	286	121	175	283	514	521	203	249	54.88	45.35
	125/150# Flgd.	103	222										57.60	48.07
	250/300# Flgd.	110	235										61.23	51.70
(50) **	NPT	108	235	356	286	162	214	322	546	559	278	324	73.02	63.49
	125/150# Flgd.	117	254										78.46	58.94
	250/300# Flgd.	124	267										80.27	70.75
(65)	125/150# Flgd.	129	276	356	286	162	214	322	546	559	278	324	91.16	81.63
	250/300# Flgd.	137	292										93.42	83.90
(80)	125/150# Flgd.	140	298	356	286	195	247	356	578	597	286	332	102.50	92.97
	250/300# Flgd.	149	318										106.12	96.60
(100)	125/150# Flgd.	167	352	356	286	195	247	356	578	597	286	332	113.83	104.31
	250/300# Flgd.	175	368										122.00	112.47

* DN40 Size CS body material with Opt-34: "A" dim. = 185mm & "B" dim = 356mm.
 ** DN50 Size CS body material with Opt-34: "A" dim. = 187mm & "B" dim = 356mm.

NOTES

The contents of this publication are presented for informational purposes only, and while every effort has been made to ensure their accuracy, they are not to be construed as warranties or guarantees, express or implied, regarding the products or services described herein or their use or applicability. We reserve the right to modify or improve the designs or specifications of such product at any time without notice. Cashco, Inc. does not assume responsibility for the selection, use or maintenance of any product. Responsibility for proper selection, use and maintenance of any Cashco, Inc. product remains solely with the purchaser.

MODEL 8310LP PRODUCT CODER

An "X" in POS 12 followed by a 5-digit control number overrides remaining selections.



POSITION 3 - SIZE		
Size		CODE
in	(DN)	
1-1/2"	(40)	8
2"	(50)	9
2-1/2" *	(65)	A
3" *	(80)	B
4" *	(100)	C

* Flanged Only.

POSITION 5 - BODY / SPRING CHAMBER MATERIAL	
Body / Sp. Ch.	CODE
CI/CI	1
CS/CS	5

NOTE: See TB Table 2 for material limitations of Design Pressure Ratings.

POSITION 6 & 7 - TRIM	
Desig.	CODE
S1	S1
S5	S5
S40	40

POSITION 8 - Product Classification Under European "Pressure Equipment Directive"		
PRODUCT DESTINATION	HAZARD CATEGORY	CODE
Anywhere except Europe	N/A	7
European Countries *	Sound Engineering Practice (SEP)	S
	CE Marked Hazard Cat I or II	E
	ATEX	A

* For products to be placed in service in Europe - Ref to Directive 97/23/EC. Forward Completed "EU" Application Recorder prior to quotation. (Without Recorder- Processing of Purchase Order will be delayed). Contact Cashco for Assistance.

POSITION 10 - END CONNECTIONS	
Description	CODE
NPT - Screwed	1
-30 Opt. Integral Flanged	
125 LB Flgs CI Only	3
150 LB Flgs CS Only	6
250 LB Flgs CI Only	5
300 LB Flgs CS Only	7
-34 Opt. - 150 LB RF Flgs. 14" F to F Dimension (Sizes 1-1/2" & 2" only) *	V
-34 Opt. - 300 LB RF Flgs. 14" F to F Dimension (Sizes 1-1/2" & 2" only) *	W

* CS body material only. Nipples & flanges of same material as body.

POSITION 11 - RANGE SPRINGS		
Steel Range Spring		CODE
psig	(Barg)	
1 - 4 *	(.07-.27)	5
3 - 10	(.21-.69)	6
8 - 30	(.55-2.1)	7

* Composition Diaphragm Only.

POSITION 12 - TRIM VARIATIONS		
Description	Option	CODE
No Special Trim Variation	--	0
Stellited Seat Surface - S1 and S5 Trim Only.	-15	A
For Special Construction Contact Cashco for Special Product Code.	SPQ	X

POSITION 13 - FEATURE OPTIONS		
Description	Option	CODE
No Option	-	0
Closing Cap.	-1	1
T-Bar & Locking Lever.	-3	3

POSITION 16 - CERTIFICATE OPTIONS		
Description	Option	CODE
No Option	-	0
Special Cleaning: Per Cashco Spec #S-1542.	-56	N

POSITION 17 - PAINT OPTIONS		
Description	Option	CODE
No Option	-	0
Epoxy Painted Per Cashco Spec #S-1547.	-95	W
Epoxy Painted Per Cashco Spec #S-1687 Offshore Applic.	-95OS	Y

MODEL 8310HP PRODUCT CODER 05/31/16

An "X" in POS 12 followed by a 5-digit control number overrides remaining selections.

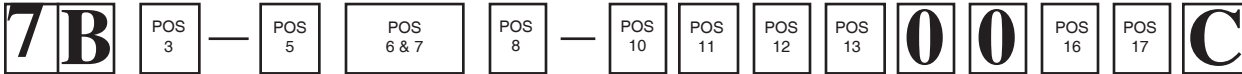

POSITION 3 - SIZE		
Size		CODE
in	(DN)	
1-1/2"	(40)	8
2"	(50)	9
2-1/2" *	(65)	A
3" *	(80)	B
4" *	(100)	C
* Flanged Only.		

POSITION 5 - BODY / SPRING CHAMBER MATERIAL	
Body / Sp. Ch.	CODE
CI/DI	1
CS/CS	5
NOTE: See TB Table 1 for material limitations of Design Pressure Ratings.	

POSITION 6 & 7 - TRIM	
Desig.	CODE
S1	S1
S5	S5
S40	40

POSITION 8 - Product Classification Under European "Pressure Equipment Directive"		
PRODUCT DESTINATION	HAZARD CATEGORY	CODE
Anywhere except Europe	N/A	7
European Countries *	Sound Engineering Practice (SEP)	S
	CE Marked Hazard Cat I or II	E
	ATEX	A
* For products to be placed in service in Europe - Ref to Directive 97/23/EC. Forward Completed "EU" Application Recorder prior to quotation. (Without Recorder- Processing of Purchase Order will be delayed). Contact Cashco for Assistance.		

POSITION 10 - END CONNECTIONS	
Description	CODE
NPT - Screwed	1
-30 Opt. Integral Flanged	
125 LB Flgs CI Only	3
150 LB Flgs CS Only	6
250 LB Flgs CI Only	5
300 LB Flgs CS Only	7
-34 Opt. - 150 LB RF Flgs. 14" F to F Dimension (Sizes 1-1/2" & 2" only) *	V
-34 Opt. - 300 LB RF Flgs. 14" F to F Dimension (Sizes 1-1/2" & 2" only) *	W
* CS body material only. Nipples & flanges of same material as body.	

POSITION 11 - RANGE SPRINGS		
Steel Range Spring		CODE
psig	(Barg)	
10 - 40	(.69-2.8)	1
30 - 100	(2.1-6.9)	8
75 - 145	(5.2-10.0)	9
130 - 200 *	(9.0-13.8)	B
Option-20 Dome Loaded		A
* Includes Opt-80 for High Outlet pressure construction.		

POSITION 12 - TRIM VARIATIONS		
Description	Option	CODE
No Special Trim Variation	--	0
Stellited Seat Surface - S1 and S5 Trim Only.	-15	A
For Special Construction Contact Cashco for Special Product Code.	SPQ	X

POSITION 13 - FEATURE OPTIONS		
Description	Option	CODE
No Option	-	0
Closing Cap.	-1	1
T-Bar & Locking Lever.	-3	3

POSITION 16 - CERTIFICATE OPTIONS		
Description	Option	CODE
No Option	-	0
Special Cleaning: Per Cashco Spec #S-1542.	-56	N

POSITION 17 - PAINT OPTIONS		
Description	Option	CODE
No Option	-	0
Epoxy Painted Per Cashco Spec #S-1547.	-95	W
Epoxy Painted Per Cashco Spec #S-1687 Offshore Applic	-95OS	Y

Cashco, Inc.
P.O. Box 6
Ellsworth, KS 67439-0006
PH (785) 472-4461
Fax. # (785) 472-3539
www.cashco.com
email: sales@cashco.com
Printed in U.S.A. 8310-TB

Cashco GmbH
Handwerkerstrasse 15
15366 Hoppegarten, Germany
PH +49 3342 30968 0
Fax. No. +49 3342 30968 29
www.cashco.com
email: germany@cashco.com

Cashco do Brasil, Ltda.
Al.Venus, 340
Indaiatuba - Sao Paulo, Brazil
PH +55 11 99677 7177
Fax. No.
www.cashco.com
email: brazil@cashco.com