



MODEL ULR-1

DIRECT-ACTING, PRESSURE LOADED, PRESSURE REDUCING REGULATOR with BACK PRESSURE UNLOADER

SECTION I

I. DESCRIPTION AND SCOPE

The Model ULR-1 uses the pressure set point of a back pressure regulator (Unloader) to control the outlet pressure of the reducing regulator. Sizes are 1/2" (DN15), 3/4" (DN20), 1" (DN25), 1-1/4" (DN32), 1-1/2" (DN40), 2" (DN50), 3" (DN80) and 4" (DN100). This model is suitable for gaseous applications.

SECTION II

II. REFERENCES

Refer to Technical Bulletin ULR-1-TB for technical specifications for this regulator.

ABBREVIATIONS

CW	–	Clockwise
CCW	–	Counter Clockwise
ITA	–	Inner Trim Assembly

SECTION III

III. INSTALLATION



CAUTION

For welded installations, all internal trim parts, seals and diaphragm(s) must be removed from regulator body prior to welding into pipeline. The heat of fusion welding will damage non-metallic parts if not removed.



CAUTION

Installation of adequate overpressure protection is recommended to protect the regulator from overpressure and all downstream equipment from damage in the event of regulator failure.

1. This regulator may be rotated around pipe axis 360 degrees. For ease of maintenance, the recommended position is with the cover dome (25) upwards.
2. Provide space below, above, and around regulator for removal of parts during maintenance.
3. Install block valves and pressure gauges to provide means for adjustment, operation, bypass, or removal of the regulator. A pipeline strainer is recommended before inlet to remove typical pipeline debris from entering valve and damaging internal "soft goods", primarily the dynamic seal.
4. Downstream Sensing Installation Considerations – Internal or External Sensing:
 - a. The regulator may be installed with internal or external sensing. Unless otherwise specified, the regulator is supplied by factory with internal sensing. The regulator may be converted in the field to external sensing. (See Section VII Maintenance, Part G – Converting Internal/ External Sensing.
 - b. Reference ULR-1-TB, Table -11 for recommendations when to apply external sensing.
 - c. For internal sensing, no external line is required. For external sensing, use an external control line. The line is connected from the 1/4" (DN8) NPT tap (Port 5 – See Fig. 5) on the side of the body diaphragm flange to a pressure tap downstream of the regulator. Use 1/4" or 3/8" (DN8 or 10) outer diameter tubing or 3/8" (DN10) pipe having an inner diameter equivalent to Schedule 40 pipe.

⚠ CAUTION

DO NOT HYDROSTATIC TEST THROUGH AN INSTALLED UNIT; ISOLATE REGULATOR FROM TEST. The "OUTLET RATING" as printed on the nameplate is the recommended "upper operating limit" for the sensing diaphragm. Higher pressures could cause internal damage. In addition, note on the nameplate that the Inlet and Outlet pressure and temperature ratings are at different levels.

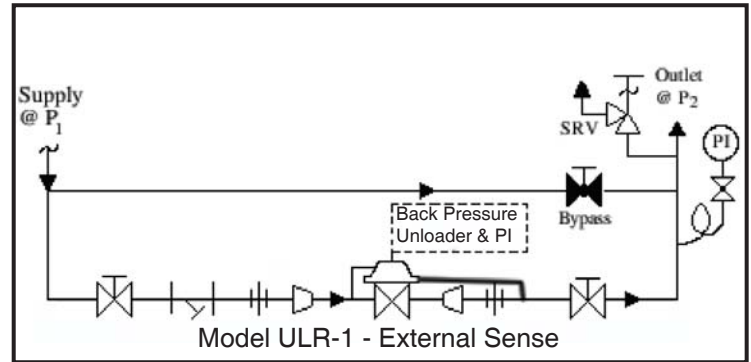

Recommended Piping Schematic
For Pressure Reducing Station

SECTION IV

IV. PRINCIPLE OF OPERATION

1. When a loading pressure – P_{Load} – is applied to the top side of a diaphragm, the outlet controlled pressure – P_2 – will balance at approximately .90 – .98 of the loading pressure - P_L . (**NOTE:** *Fluctuations in P_1 – Inlet Pressure will cause a deviation in P_2 – Outlet Pressure due to inverse sympathetic ratio effect.*) See Section VIII.
2. Movement occurs as pressure variations register on the diaphragm. The registering pressure is the outlet, P_2 , or downstream pressure. The loading

pressure fluid opposes diaphragm movement. As outlet pressure drops, the loading pressure pushes the diaphragm down, opening the port; as outlet pressure increases, the diaphragm pushes up and the port opening closes.

3. A diaphragm failure will tend to cause the regulator to fall below setpoint. A loss of loading pressure while inlet pressure is imposed will cause the regulator to fail close. A complete diaphragm failure will cause the inlet process fluid to mix with the loading fluid.

SECTION V

V. STARTUP

1. Start with the block valves closed.
2. Rotate the adjusting screw of the unloader CCW three revolutions to decrease the set point pressure of the main regulator.
3. If it is a "hot" piping system, and equipped with a bypass valve, slowly open the bypass valve to preheat the system piping and to allow slow expansion of the piping. Closely monitor outlet (downstream) pressure via gauge to ensure not over-pressurizing. **NOTE:** *If no bypass valve is installed, extra caution should be used in starting up a cold system; i.e. do everything slowly.*
4. Crack open the outlet (downstream) block valve to approximately 10% full open.
5. Slowly open the inlet (upstream) block valve to about 25% open. Rotate the adjusting screw on the unloader CW to increase the setpoint pressure if necessary until the main valve is flowing. Observe the outlet pressure gauge to ensure not overpressurizing.
6. Continue to slowly open the inlet (upstream) block valve until fully open.
7. Continue to slowly open the outlet (downstream) block valve, especially when the downstream piping system isn't pressurized. If the outlet (downstream) pressure exceeds the desired pressure, close the inlet block valve and go to Step 2. Close bypass valve approximately 25%, and repeat procedure.

⚠ CAUTION

Do not walk away and leave a bypassed regulator unattended!

8. When flow is established steady enough that the outlet (downstream) block valve is fully open, begin to slowly close the bypass valve if installed.
9. Develop system flow to a level near its expected normal rate, and reset the pressure for the main regulator to the desired outlet pressure by adjusting the unloader pressure setpoint.

10. Reduce system flow to a minimum level and observe pressure set point. Outlet pressure will rise from the set point of Step 9 for a Model ULR-1. The maximum rise in outlet pressure on decreasing flow should not exceed the 10%. If it does, consult factory.

SECTION VI

VI. SHUTDOWN

1. On systems with a bypass valve, and where system pressure is to be maintained as the regulator is shut down, slowly open the bypass valve while closing the inlet (upstream) block valve. Fully close the inlet (upstream) block valve. (When on bypass, the system pressure must be constantly observed and manually regulated. Close the outlet (downstream) block valve.

CAUTION

Do not walk away and leave a bypassed regulator unattended.

2. Rotate the unloader adjusting screw CCW until removed to relieve any trapped upstream loading pressure in the dome.
3. If the regulator and system are to both be shut down, slowly close the inlet (upstream) block valve. Close the outlet (downstream) valve only if regulator removal is required.

SECTION VII

VII. MAINTENANCE

A. General:

WARNING

SYSTEM UNDER PRESSURE. Prior to performing any maintenance, isolate the regulator from the system and relieve all pressure. Failure to do so could result in personal injury.

1. The ULR-1 may be serviced without removing the regulator from pipeline. The regulator is designed with quick-change trim to simplify maintenance.
2. Record the nameplate information to requisition repair parts for the regulator. The information should include: size, Product Code, Serial Number, and internal or external sensing. (**NOTE: Never both types of sensing.**) If external sensing is used, be sure that the external sensing line is dis-connected.
3. Refer to Section X for recommended repair parts. Only use original equipment parts supplied by Cashco for rebuilding or repairing regulators.
4. Owner should refer to owner's procedures for removal, handling, cleaning and disposal of nonreusable parts, i.e. gaskets, etc.

NOTE: On regulators originally supplied as "oxygen clean" – Opt-55, maintenance must include a level of cleanliness equal to Cashco cleaning standard #S-1134.

5. The Inner Trim Assembly (Figure 3) is removed and replaced in the body (23) as an assemblage of parts. The Inner Trim Assembly, hereinafter called **ITA**, consists of the following parts:

Item No.	Dynamic Seal Type	Part Description
13	All	Guide Bearing
14	All	Static Stem Seal
14.1	All	Upper Static Stem Seal
14.2	All	Middle Static Stem Seal
14.3	All	Lower Static Stem Seal
15	All	Cage O-ring Seal
16	CW	Wiper
17.1	CW	Wiper Washer
17.3	UC	Seal Retainer
19	All	Cage
20	All	Valve Plug
21	All	Seat Ring
27	All	Dynamic Side Seal
27.1	CW	TFE Cap Seal
27.2	CW	O-ring Energizer/Seal
27.3	UC	U-Cup Seal w/Metal Energizer
27.4	OR	O-Ring Seal

A detailed view of the dynamic side seal parts is shown in Figure 1 on the next page.

Figure 1: Dynamic Side Seals

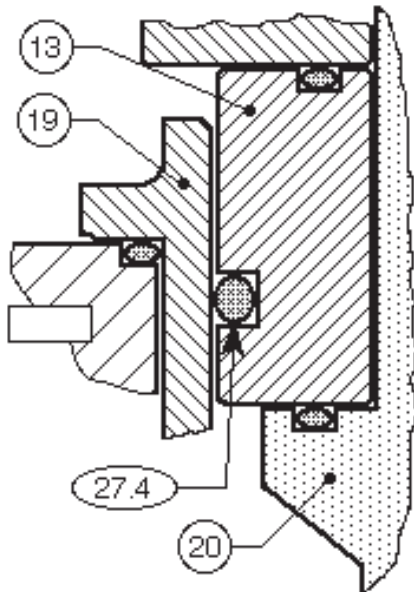

**Type OR — O-Ring
Dynamic Seal**

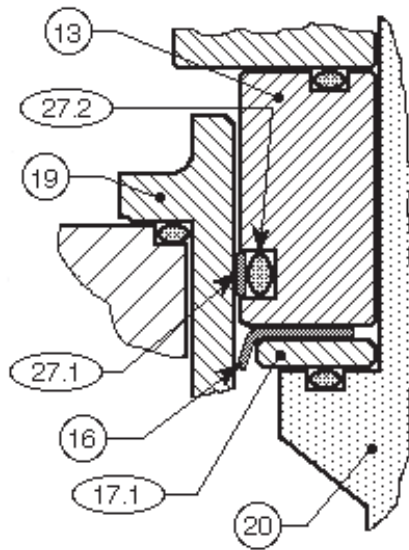

**Type CW — TFE Cap
Dynamic Seal + Wiper**

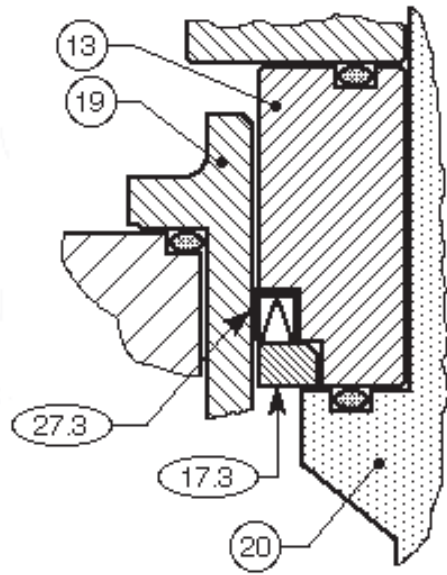

**Type UC — U-Cup
Dynamic Seal**

B. Main Regulator Disassembly:

⚠ WARNING

SYSTEM UNDER PRESSURE. Prior to performing any maintenance, isolate the regulator from the system and relieve all pressure. Failure to do so could result in personal injury.

1. Shut down system in accordance Section VI.
2. Disconnect the external sensing line, if installed. Disconnect tubing at inlet connection of the main regulator body.
3. Though it is possible to disassemble the valve unit while installed in a pipeline, it is recommended that maintenance be done in a shop when possible. The instructions hereafter will assume shop disassembly. Remove valve from pipeline.
4. Place the regulator body in a vise with the cover dome (25) upwards.
5. Loosen the diaphragm flange bolts (11) and nuts (12) uniformly.
6. Place matchmarks on body (23) and cover dome (25) flanges. Remove cover dome (25).

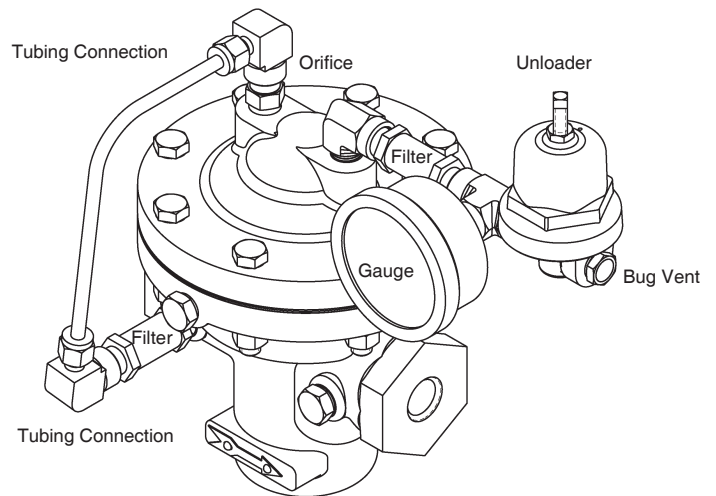

Figure 2

7. Hold the milled “flats” on top of the valve plug (20) stationary, rotate the diaphragm lock nut (7) CCW to remove.
8. Remove upper diaphragm plate (8).
9. Remove diaphragm (9) and o-ring upper stem seal (14.1). Examine diaphragm to determine whether failed; determine if operating conditions are exceeding pressure, pressure drop or temperature limits.

10. Remove lower diaphragm plate (10).
11. Evenly loosen the three cage cap screws (18) in single revolution increments. **NOTE:** *Regulator may contain a lower piston spring (22); the ITA should rise as the cage cap screws (18) are evenly backed out. A downwards holding force should be applied to the top of the piston-guide bearing (13) to prevent the ITA from popping up as the last threads of the cage cap screws (18) are backed out.*
12. Remove the ITA by pulling up on the valve plug (20). Set ITA aside.

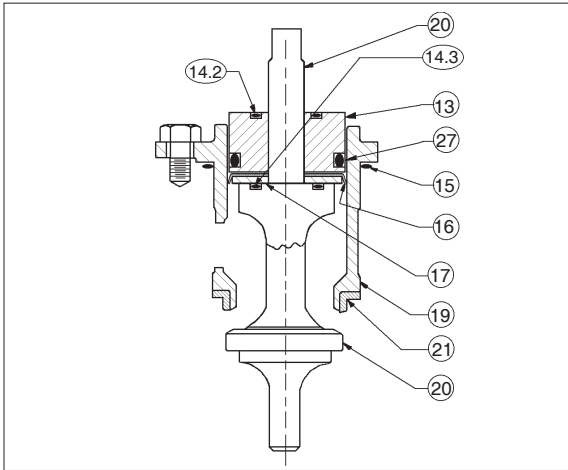

Figure 3: Assembled ITA

13. Remove the lower piston spring (22), as applicable, from within the body (23).
14. Remove o-ring cage seal (15).
15. If supplied, remove internal sensing drilled plug (33) using 5/32" (4 mm) Allen wrench.
16. Remove body (23) from vise. Clean all reusable metal parts according to owner's procedures.

C. Disassembly of the ITA: (See Figure 3)

1. Pull the valve plug (20) downwards and out of the guide bearing (13) and cage (19).
2. Remove the guide bearing (13) from the upper end of the cage (19).
3. Remove o-ring middle stem seal (14.2) from guide bearing (13).
4. Examine the components (27.1, 27.2, 27.3, 27.4) of the dynamic side seal (27) mechanism to determine if significant leakage was occur-

ring. If the dynamic side seal (27) shows signs of significant leakage, determine if operating conditions are exceeding pressure, pressure drop, or temperature limits.

Remove dynamic side seal (27) components. Special care should be taken when using "tools" to remove the components to ensure that no scratches are imparted to any portion of the guide bearing (13) groove.

5. Remove wiper seal (16), if supplied, from within cage (19) I.D.
6. Remove wiper washer (17.1) from within the cage (19) I.D.
7. Remove o-ring lower stem seal (14.3) from plug (20).
8. Remove seat ring (21); examine for signs of leakage. If seat ring shows signs of significant leakage, determine if operating conditions of pressure, pressure drop, or temperature are exceeding limits.
9. Clean all reusable metal parts according to owner's procedures.

D. Inspection of Parts:

1. After inspection remove from the work area and discard the old "soft goods" parts (i.e. o-rings, diaphragms, seals, gaskets, etc.) after inspection. These parts **MUST** be replaced with factory supplied new parts.
2. Inspect metal parts that will be reused. The parts should be free of surface contaminants, burrs, oxides, and scale. Rework and clean parts as necessary. Surface conditions that affect the regulator performance are stated below; replace parts that can not be reworked or cleaned.
3. QC Requirements:
 - a. Valve plug (20);
 1. 16 rms finish on its seating surface for tight shutoff.
 2. No major defects on bottom guide spindle.
 - b. Cage (19);
 1. 16 rms finish on cylinder bore. No "ledges" formed due to wear from moving dynamic side seal (27) or wiper seal (16).
 - c. Lower guide bushing (24) (non-replaceable):

1. 16 rms finish on bore.
 2. Max 0.015 inch (0.38 mm) clearance between valve plug (20) spindle and lower guide bushing (24).
 - d. Internal sensing drilled plug (33);
 1. Ensure that bore is minimum 0.125 inch (3.20 mm). Drill out as required.
4. Staging Material for Reassembly.
- a. Inspect and clean parts, as necessary, from the spare parts kit. (See Article VII .A.4. comments concerning cleaning for oxygen service.)
 - b. Lay out all the regulator parts and check against the bill of material.

E. Reassembly of the ITA:

1. When replacing the optional wiper seal (16), the replacement wiper seal (16) is “pre-formed”. It may, however, require reforming. Under normal circumstances, this step may not be required. If needed, reform the wiper seal (16) by pressing the temporary assembly parts into the cage (19) backwards as shown in Figure 4. The wiper seal (16) is best left in this position overnight (minimum of two (2) hours) prior to reassembly.

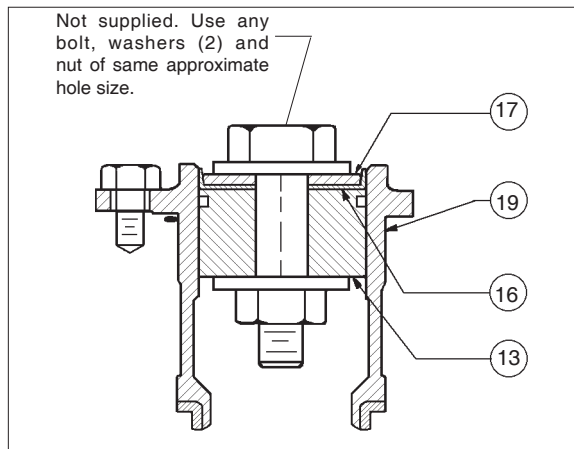

Figure 4: Temporary Assembly Parts

2. After forming the wiper seal, remove parts (13, 16, 17) from cage (19) and disassemble the temporary assembly of Step 1. above.
3. Installation of dynamic side seal (27) (See Figure 1):
 - a. Type OR:
 1. Stretch o-ring seal (27.4) over lower circumference of guide bearing (13), taking care not to “cut” o-ring seal (27.4). Using thumbs, work the o-ring

seal (27.4) up and into the groove of the guide bearing (13). **NOTE:** A very slight amount of fluid and elastomer compatible lubricant is recommended as an installation aid.

2. Position guide bearing (13) over upper end of cage (19) properly oriented. Using thumbs, evenly press guide bearing (13) into the cage (19), ensuring not to “cut” o-ring seal (27.4). Continue pressing guide bearing (13) until in approximate final position.
- b. Type CW:
 1. Stretch o-ring energizer/seal (27.2) over lower circumference of guide bearing (13), taking care not to “cut” o-ring energizer/seal (27.2). Using thumbs, work the o-ring energizer/seal up and into the groove of the bearing (13). **NOTE:** A very slight amount of fluid and elastomer compatible lubricant is recommended as an installation aid.
 2. Place wiper washer (17.1) into “cup” of Wiper Seal (16). Holding these parts (17.1 & 16) between thumb and forefinger, insert into cage (19) at an approximate 45° angled approach with wiper washer (17.1) on bottom, wiper seal (16) on top with turned-down lip of wiper seal (16) entering cage (19) first. Rotate wiper seal (16) and wiper washer (17.1) to a level position approximately half way down into cage (19). Allow wiper washer (17.1) to rest on bottom of cage (19).
 3. Position TFE cap seal (27.1) ring with rectangular cross-section at end of guide bearing (13). Stretch cap seal (27.1) over lower end of guide bearing (13) using thumbs to work the cap seal (27.1) onto the bearing (13). **DO NOT USE A TOOL FOR THIS STEP.** Continue pressing cap seal (27.1) upwards towards the groove until the cap seal (27.1) “snaps” into the groove of the guide bearing (13).
 4. Position guide bearing (13) over and into upper end of cage (19) until the cap seal (27.1) edge touches the upper lip of the cage (19). While gently applying force to press the guide bushing (13) into the cage (19), simultaneously use fingers to lightly press the cap seal (27.1) inwards into the groove of the guide bearing (13)

until the cap seal (27.1) “slips into” the cage (19). **DO NOT USE TOOLS, LUBRICANT, OR HEAVY FORCE TO ENGAGE THE CAP SEAL (27.1) INTO THE CAGE (19).** Do not press inwards on the Cap Seal (27.1) too much or the cap seal (27.1) may slide out of its groove or the cap seal (27.1) can be damaged.

c. Type UC:

1. Stretch u-cup seal (27.3) over lower circumference of guide bearing (13), taking care not to “cut” u-cup seal (27.3) on the protruding shelf that is part of the guide bearing’s (13) groove. Ensure that the u-cup seal (27.3) is oriented with the center-open-downwards as shown in Figure 1, as the u-cup seal (27.3) depends upon the P1-Inlet Pressure to pressure activate the seal for proper sealing action.
2. Position guide bearing (13) over and into upper end of cage (19) until the cap seal (27.1) edge touches the upper lip of the cage. While gently applying force to press the guide bearing (13) into the cage (19), simultaneously use fingers to lightly press the u-cup seal (27.3) inwards into the groove of the guide bearing (13) until the u-cup seal (27.3) “slips into” the cage (19). **DO NOT USE TOOLS, LUBRICANT, OR HEAVY FORCE TO ENGAGE THE U-CUP SEAL (27.3) INTO THE CAGE (19).**
4. Place properly oriented seat ring (21) onto the shoulder at the lower end of cage (19).
5. Place new o-ring lower stem seal (14.3) into groove of valve plug (20).
6. Insert valve plug (20) upwards through lower end of cage (19) and through the center hole in guide bearing (13), also capturing the wiper washer (17.1) and wiper seal (16), if supplied. Hold plug (20) and cage (19) together.
7. Place an oversized nut or stack of washers, the same approximate height of the upper diaphragm plate (8) and the lower diaphragm plate (10), over the upper end of valve plug (20) and temporarily secure with diaphragm lock nut (7), manually tightened. Do **NOT** allow valve plug (20) to rotate against seat ring (21) during tightening.

8. This completes ITA preliminary/partial reassembly.

F. Main Regulator Reassembly:

1. Place body (23) in a vise.
2. Reinstall internal sensing drilled plug (33) with compatible thread sealant.
3. Insert the lower piston spring (22) into the body (23), if supplied.
4. Fit the o-ring cage seal (15) into its body (23) groove.
5. With the ITA held manually in the closed position, insert ITA into body (23).
6. Properly align all three cage bolt (18) holes as there is only one circumferential location possible for this alignment. If a lower piston spring (22) is used, apply downward force to the top of the cage (19) until the ITA is lowered sufficiently to engage the cage bolts (18) into the body (23). Engage all of the cage bolts (18), then evenly screw in the cage bolts in one-half revolution increments to pull down the ITA evenly, taking care **NOT TO “ANGLE”** the ITA in the BODY. Torque the cage bolts (18) to 13-15 ft-lbs (17.6-20.3 N-m).
7. For the following steps a.– g., the upper end of valve plug (20) **MUST** be manually held up if unit is not supplied with lower piston spring (22).
 - a. Remove temporarily installed diaphragm lock nut (7) and spacers of previous Step E.7 this Section.
 - b. Place new o-ring middle stem seal (14.2) into groove of piston-guide bearing (13) upper surface.
 - c. Position lower diaphragm plate (10) over upper end of plug (20) with tongue and groove “groove” on upper side.
 - d. Place new o-ring upper stem seal (14.1) over upper end of valve plug (20).
 - e. Place diaphragm (9) over end of valve plug (20).
 - f. Place upper diaphragm plate (8) over upper end of plug (20) with tongue and groove “ridge” on lower side.
 - g. Place lubricant on valve plug (20) threaded end. Engage diaphragm lock nut (7) with upper end of valve stem (20) as far as possible manually.
 - h. Place a wrench on diaphragm lock nut (7)

and a torque wrench on the upper end of valve plug (20). Hold torque wrench stationary and rotate diaphragm lock nut (7) to the following torque values:

Body Size in (DN)	Torque Value Ft-lbs (N-m)
1/2" - 1" (15 - 25)	60 - 70 (81 - 95)
1 1/4" - 2" (32 - 50)	120 - 130 (163 - 176)
2 1/2" - 4" (65 - 100)	180 - 200 (244 - 271)

DO NOT allow valve plug (20) to rotate against seat ring (21) during tightening.

- i. This completes ITA reassembly.
8. Aligning matchmarks and bolt holes, place cover dome (25) onto body (23).
9. Reinstall all flange bolts (11) and nuts (12) with nameplate (99) located under one bolt head. Hand-tighten nuts (12).
10. Evenly tighten the body bolting (11,12) in an alternating cross pattern in one revolution increments to the following torque values:

Body Size in (Dn)	Torque Value Ft-lbs (N-m)
1/2" - 2" (15 - 50)	30 - 35 (41 - 47)
2 1/2" - 4" (65 - 100)	45 - 50 (61 - 69)

G. Converting Internal/External Sensing:

1. Disassemble the regulator and remove the diaphragm (9) according to Steps 1-12 in Part B – Main Regulator Disassembly.
2. To convert from internal to external sensing, remove the drilled pipe plug (33) and install a solid pipe plug (32). Connect external sensing line to port 5 on side of the body. Reverse this step for converting from external to internal sensing. Disconnect external sensing line.
3. Reassemble the regulator according to Part F – Main Regulator Reassembly.

H. Pressure Testing:

1. If a hydrostatic pressure test is performed, pressure must be applied to all three of cover dome (25), inlet and outlet of body at the same level.
DO NOT HYDROSTATICALLY TEST WITHOUT COVER DOME PRESSURIZED. NOT ADHERING WILL DO PHYSICAL DAMAGE TO INTERNALS THAT COULD RENDER THE UNIT INOPERABLE.

2. Inboard Leakage Test.

- a. Release all loading pressure in cover dome.
- b. Pressurize inlet to 30 psig (2.1 Barg) with air or GN₂.
- c. Tube outlet to a beaker of water to observe number of escaping gas bubbles.

Inboard leakage path may be via plug/seat or dynamic side seal.

3. Pressure Containment Test.

- a. Pressurize inlet to 200 psig (13.8 Barg) and outlet and cover dome to 150 psig (10.3 Barg) with air or GN₂.
- b. Spray liquid lead detector and check all external leak points; i.e. plugged connections, diaphragm flange and diaphragm bolting.

4. Excessive leakage will require disassembly, examination of sealing elements, correction of problem, reassembly and retesting.

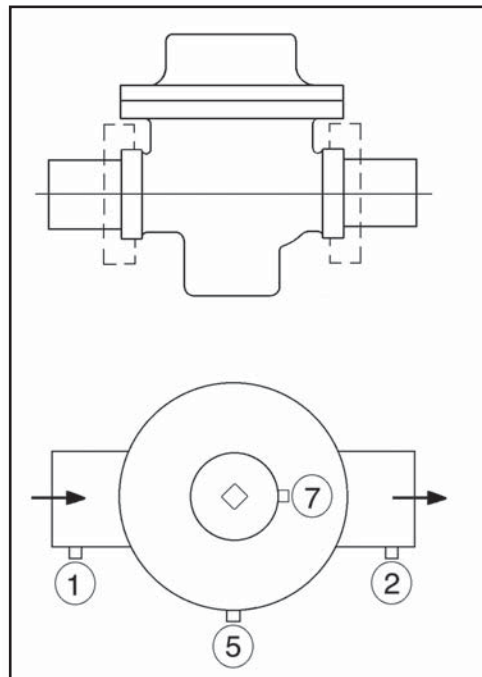

Figure 5: Location of Auxiliary Ports

I. UnLoader Disassembly:



WARNING

SYSTEM UNDER PRESSURE. Prior to performing any maintenance, isolate the regulator from the system and relieve all pressure. Failure to do so could result in personal injury.

J. General:

1. Maintenance procedures hereinafter are based upon removal of the regulator unit from the pipeline where installed.
2. Owner should refer to owner's procedures for removal, handling, cleaning and disposal of non-reuseable parts, i.e. gaskets, etc.
3. Refer to Unloader drawing for item numbers.
4. Remove Unloader from piping.

K. Diaphragm Replacement



CAUTION

To prevent damage to body, use lead jaws when placing body in a vise. Position so that vise closes over inlet and outlet of the body.

1. Securely install the body (1) in a vise with the spring chamber (2) directed upwards.



WARNING

SPRING UNDER COMPRESSION. Prior to removing spring chamber, relieve spring compression by backing out the adjusting screw. Failure to do so may result in flying parts that could cause personal injury.

2. Relax range spring (6) by loosening the lock-nut (4) and turning adjusting screw (3) CCW until removed from spring chamber (2).
3. Loosen spring chamber (2) by placing wrench on "flats" and rotating CCW.
4. Remove spring chamber (2), spring button (5) range spring (6), and travel stop (9).
5. Remove the diaphragm subassembly consisting of the pressure plate nut (7), lock washer (8), pressure plate (10), diaphragm

(11), plug gasket (13) and plug (14). **NOTE:** Refer to the quantity of diaphragms (11) incorporated per the bill of materials listing. Depending on inlet pressure level, multiple metal diaphragms (11) may be "stacked".

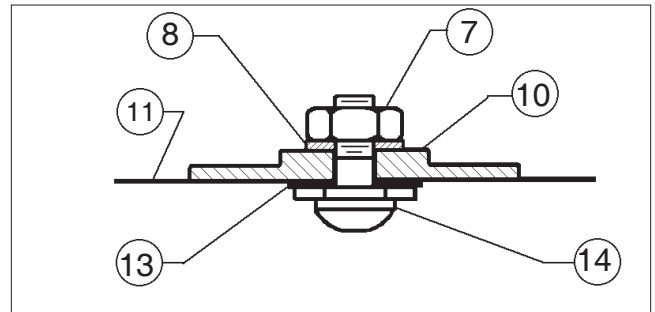

Diaphragm Subassembly

6. Loosen pressure plate nut (7) and separate all parts (7, 8, 10, 11, 13 & 14) of the diaphragm subassembly.
7. Inspect pressure plate (10) to ensure no deformation due to over-pressurization. If deformed, replace.
8. Remove diaphragm gasket (12).
9. Clean body (1) and diaphragm flange. **NOTE:** On regulators originally supplied as "oxygen clean", Option -55, maintenance must include a level of cleanliness equal to Cashco's cleaning standard #S-1134. Contact factory for details.
10. Reassemble diaphragm subassembly by placing plug gasket (13), diaphragm(s) (11), pressure plate (10) and lock washer (8) over threaded post of plug (14). Ensure the pressure plate (10) is placed with curved outer rim down next to the diaphragm (11) surface.

Place a thread sealant compound similar to Loctite #271 on the threads of the plug's (14) post prior to tightening the pressure plate nut (7) to 60 In-lbs. (6.8 N-m).

11. Place diaphragm gasket (12) on body (1), then insert the diaphragm subassembly into the body (1).
12. Place travel stop (9) and range spring (6) over the pressure plate nut (7) of the diaphragm subassembly.
13. Place multi-purpose, high temperature grease into depression of spring button (5) where adjusting screw (3) bears. Set spring

button (5) onto range spring (6); ensure spring button (5) is laying flat.

14. Rotate the spring chamber (2) CW by hand into the threaded portion of the body (1) assuring not to cross thread. Continue hand rotating CW until firmly seated against the diaphragm stop (9). Wrench tighten securely to 20 - 25 Ft-lbs. (27 - 34 N-m)
15. Reinstall adjusting screw (3) with locknut (4) into the spring chamber (2).
16. Pressurize with air and spray liquid leak detector to inspect entire body (1) and spring chamber (2) for leakage. Ensure that an inlet pressure is maintained during this leak test of at least mid-range spring level; i.e. 40-90 psig (2.8-6.2 Barg) range spring, 65 psig (4.5 Barg) test pressure minimum.

L. Trim Replacement

1. Trim inspection requires the diaphragm subassembly be removed. Refer to previous procedure, Section VI.K.
2. Inspect inside surface of seat ring (15) and seating surface of plug (14). If seating surface shows signs of erosion/wear, the seat ring (15) and plug (14) should be replaced.
3. Clean body (1) cavity. Clean all parts to be reused. **NOTE:** *On regulators originally supplied as "oxygen clean", Option -55, maintenance must include a level of cleanliness equal to Cashco's cleaning standard #S-1134. Contact factory for details.*
4. Inspect the surface in the body (1) cavity where seat ring (15) rests. If surface area of either mating part shows signs of erosion/wear, replace with new regulator.
5. Place seat ring (15) in center of body (1) cavity. Ensure that the shoulder on outer edge of seat ring (15) faces up towards the diaphragm (11).
6. Reinstall diaphragm subassembly per Section VI.K steps 10 thru 16.
7. Bench test unit for suitable operation. **NOTE:** *Regulators are not tight shut off devices. Even if pressure falls below set-*

point, a regulator may or may not develop bubble tight shut off.

8. Pressurize with air and spray liquid leak detector to inspect entire body (1) and spring chamber (2) for leakage. Test pressure should be the maximum allowed by the range spring at the inlet.

SECTION VIII

VIII. PRESSURE LOADING

1. The Loading pressure for the ULR-1 is supplied from the inlet (P1) and is regulated by the Back Pressure UnLoader.
2. The Model ULR-1 exhibits a deviation in outlet controlled pressure when the inlet pressure varies; this "effect" is identified as ISR – Inverse Sympathetic Ratio. Its relative pressure effect can be calculated from the following equation.

LOADING PRESSURE FOR Main Regular Assembly APPLIED PRESSURES

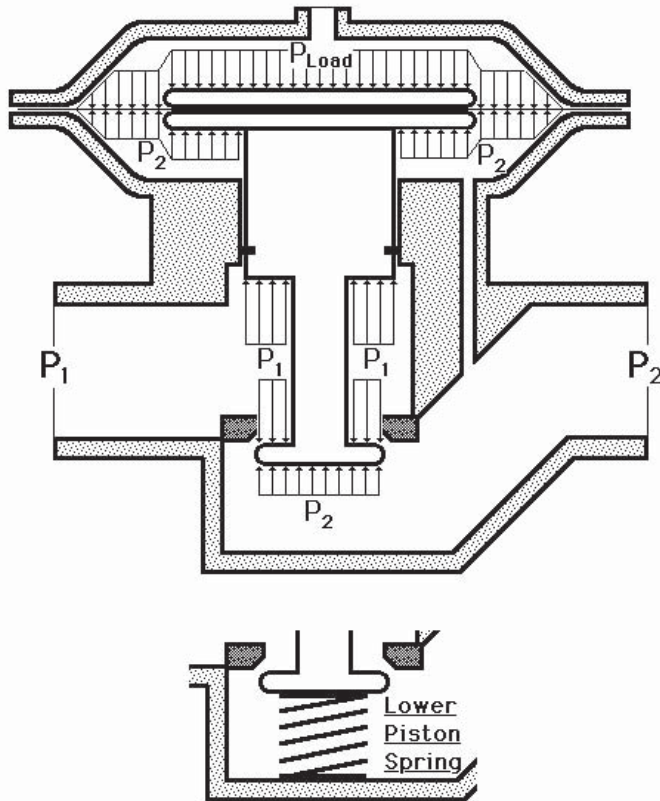

ISR FACTOR	
BODY SIZE in (DN)	ISR - %
1/2" - 1" (15 - 25)	3.0
1 1/4" - 1 1/2" (32 - 40)	4.0
2" (50)	2.0
2 1/2" - 4" (65 - 100)	5.4

PISTON SPRING		
LOWER PISTON SPRING RANGE psig (Barg)	ΔP Piston Spring psig (Barg)	LVPS psig (Barg)
none (none)	0 (0)	0 (0)
2 - 5 (.14 - .34)	3 (.21)	2 (.14)
1 - 2 (.07 - .14)	1 (.07)	1 (.07)
4 - 10 (.28 - 6.9)	6 (.41)	4 (.28)

SIZE / ORIENTATION - S/O Factor		
Body Size in (DN)	Orientation	
	Cover Dome on Top	Cover Dome on Bottom
1/2" - 1" (15 - 25)	1	-1
1 1/4" - 1 1/2" (32 - 40)	2	-2
2" (50)	2.5	-2.5
2 1/2" - 3" (65 - 80)	3	-3
4" (100)	4	-4

$$P_{LOAD} = \text{ISR Effect} + \text{Lower Piston Spring Compression Effect} + \text{Lower Piston Spring Spring Preload} + \text{Body Size Orientation Effect}$$

$$P_{Load} = P_2 + [\text{ISR} \times (P_1 - P_2)] + \left[\frac{C_{v,Req'd}}{C_{v,Max}} \times \Delta P_{Piston Spr.} \right] + LVPS + S/O_{Factor}$$

Figure 6: Loading Pressure Formula

SECTION IX

IX. TROUBLE SHOOTING GUIDE

When trouble shooting this regulator there are many possibilities as to what may be causing problems. Many times, the regulator itself is not defective, but one or more of the accessories may be. Sometimes the process may be causing difficulties.

The key to efficient trouble shooting is information and communication. The customer should try to be as precise as possible in their explanation of the problem, as well as their understanding of the application and operating conditions.

It is imperative the following information be provided by the customer:

- Fluid (with fluid properties)
- Range of flow rate
- Range of inlet pressure
- Range of outlet pressure
- Range of fluid temperature
- Range of ambient temperature

Pressure readings should be taken at every location where pressure plays a role - i.e., regulator inlet (as close as possible to inlet port), regulator outlet (as close as possible to outlet port), etc.

Following are some of the more common complaints along with possible causes and remedies.

1. Erratic regulation, instability or hunting.	
Possible Causes	Remedies
A. Sticking of internal parts.	A. Remove internals, clean, and if necessary, replace.
B. Load changes are too quick for system.	B. Convert to external sensing (if necessary) and install an orifice or needle valve in external sensing line.
C. Oversized regulator.	C. Check actual flow conditions; resize regulator for minimum and maximum flow; if necessary, replace with smaller regulator.
D. Too much variation in Inlet Pressure - P1.	D. Consider use of a pilot for closer Outlet Pressure – P2
2. Erratic regulation, instability or hunting (liquid service).	
Possible Causes	Remedies
A. Air trapped under diaphragm.	A. Install valve on external sensing port and bleed off air. (Install regulator upside down to help prevent reoccurrence.
3. Downstream pressure will not reach desired setting.	
Possible Causes	Remedies
A. Supply pressure is down (confirm on pressure gauge.	A. Increase supply pressure.
B. Undersized regulator.	B. Check actual flow conditions; resize regulator for minimum and maximum flow; if necessary, replace with larger regulator.
C. Pressure loading system pressure restricted.	C1. Clean restriction or bleed orifices. C2. Clean filter(s). C3. Clean loading pressure control device.
D. Faulty loading pressure control device.	D. Replace/repair loading pressure control device.
4. Diaphragm continually breaks (all regulators).	
Possible Causes	Remedies
A. Differential pressure across diaphragm may have exceeded limits. (See Table 1 in ULR-1-TB)	A1. Be aware of limits as well as where the various pressures are acting. Install pressure safety equipment as necessary.
5. Leakage at diaphragm flange.	
Possible Causes	Remedies
A. Body bolts not torqued properly.	A. Torque to proper value (see Section VII, F-10).
B. Pressures at diaphragm may be too high.	B. Consult factory.

6. Leakage across seat.	
Possible Causes	Remedies
A. Contamination (debris) in regulator.	A. Remove internals, clean, and if necessary, replace sealing and seating elements. *
B. Oversized regulator; valve plug operates directly next to seat.	B. Check actual flow conditions; resize regulator for minimum and maximum flow; if necessary, replace with smaller regulator.
* Seat leakage may be diagnosed when a failure of the dynamic side seal has occurred. Inspect both potential internal leak paths.	

SECTION X

X. ORDERING INFORMATION

NEW REPLACEMENT UNIT vs PARTS "KIT" FOR FIELD REPAIR

To obtain a quotation or place an order, please retrieve the Serial Number and Product Code that was stamped on the metal name plate and attached to the unit. This information can also be found on the Bill of Material ("BOM"), a parts list that was provided when unit was originally shipped. (Serial Number typically 6 digits). Product Code typical format as follows: (last digit is alpha character that reflects revision level for the product).

□□□□ - □□□□ 7 - □□□□□□□□□□

NEW REPLACEMENT UNIT:

Contact your local Cashco, Inc., Sales Representative with the Serial Number and Product code. With this information they can provide a quotation for a new unit including a complete description, price and availability.



CAUTION

Do not attempt to alter the original construction of any unit without assistance and approval from the factory. All purposed changes will require a new name plate with appropriate ratings and new product code to accommodate the recommended part(s) changes.

PARTS "KIT" for FIELD REPAIR:

Contact your local Cashco, Inc., Sales Representative with the Serial Number and Product code. Identify the parts and the quantity required to repair the unit from the "BOM" sheet that was provided when unit was originally shipped.

NOTE: *Those part numbers that have a quantity indicated under "Spare Parts" in column "A" reflect minimum parts required for inspection and rebuild, - "Soft Goods Kit". Those in column "B" include minimum trim replacement parts needed plus those "Soft Goods" parts from column "A".*

If the "BOM" is not available, refer to the cross-sectional drawings included in this manual for part identification and selection.

A Local Sales Representative will provide quotation for appropriate Kit Number, Price and Availability.

Main Regulator Assembly

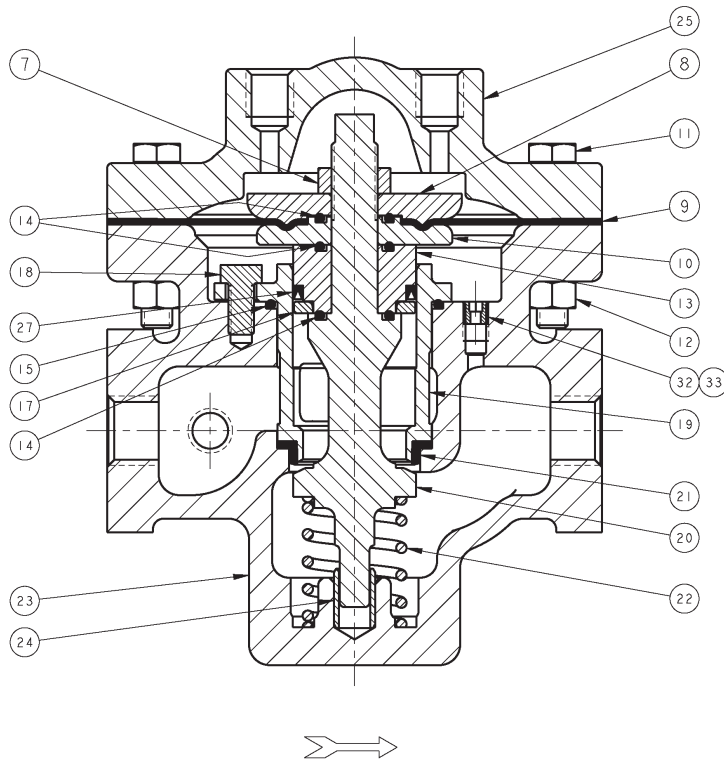

<u>Item No.</u>	<u>Description</u>	<u>Item No.</u>	<u>Description</u>
7	Diaphragm Lock Nut	21**	Seat Ring
8	Upper Diaphragm Plate	22	Lower Piston Spring (if supplied)
9**	Diaphragm	23	Body
10	Lower Diaphragm Plate	24	Lower Guide Bushing
11	Flange Bolts	25	Cover Dome
12 *	Flange Bolt Nuts	26	Plug (Not Shown)
13	Guide Bearing	27**	Dynamic Side Seal (See Figure 1)
14**	Stem Seals	32	Internal Sensing Plug – Solid (External Sensing Only)
14.1	Upper Stem Seal	33	Internal Sensing Plug – Drilled (Internal Sensing Only)
14.2	Middle Stem Seal		
14.3	Lower Stem Seal	99	Nameplate (Not Shown)
15**	Cage Seal		
17	Seal Retainer		
18	Cage Cap Screws		
19	Cage		
20	Valve Plug		

* Not required on 2" CS & SST Body Material.

** Recommended Repair Parts.

The contents of this publication are presented for informational purposes only, and while every effort has been made to ensure their accuracy, they are not to be construed as warranties or guarantees, express or implied, regarding the products or services described herein or their use or applicability. We reserve the right to modify or improve the designs or specifications of such product at any time without notice. Cashco, Inc. does not assume responsibility for the selection, use or maintenance of any product. Responsibility for proper selection, use and maintenance of any Cashco, Inc. product remains solely with the purchaser.

UnLoader

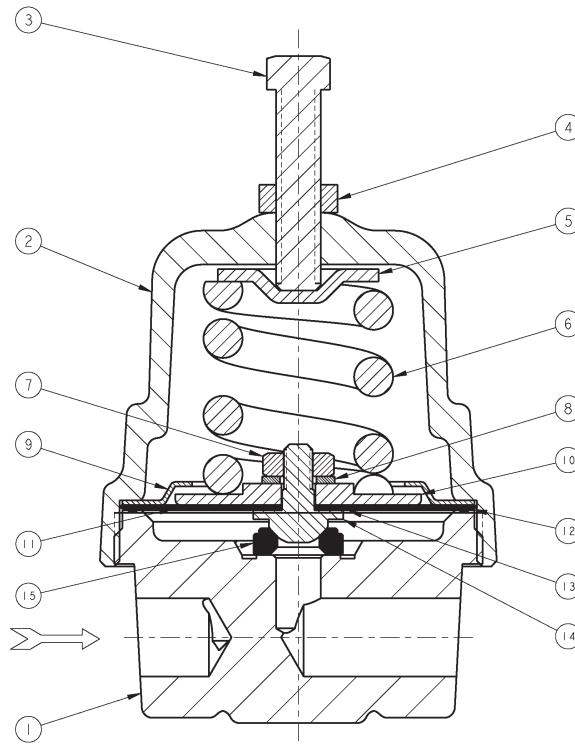

Item No.	Description
1	Body
2	Spring Chamber
3	Adjusting Screw
4	Lock Nut
5	Spring Button
6	Range Spring
7	Pressure Plate Nut
8	Lock Washer
9	Travel Stop
10	Pressure Plate
11 *	Diaphragm
12 *	Diaphragm Gasket
13 *	Plug Gasket
14 *	Plug
15 *	Seat Ring

* Recommended Repair Parts.

Cashco, Inc.
P.O. Box 6
Ellsworth, KS 67439-0006
PH (785) 472-4461
Fax. # (785) 472-3539
www.cashco.com
email: sales@cashco.com
Printed in U.S.A. ULR-1-IOM

Cashco GmbH
Handwerkerstrasse 15
15366 Hoppegarten, Germany
PH +49 3342 30968 0
Fax. No. +49 3342 30968 29
www.cashco.com
email: germany@cashco.com

Cashco do Brasil, Ltda.
Al.Venus, 340
Indaiatuba - Sao Paulo, Brazil
PH +55 11 99677 7177
Fax. No.
www.cashco.com
email: brazil@cashco.com