

MODEL 5381 PRESSURE REDUCING REGULATOR



MODEL 5381

NOTE: This valve is not self-draining, and should not be applied for applications requiring clean-in-place (CIP) or steam-in-place (SIP) capability.

The Model 5381 is a stainless steel pressure reducing regulator designed to handle small to mid-capacity flow rates in sanitary biotechnical process piping systems. This unit is capable of controlling outlet pressure to a level between 5 and 200 psig (.34 and 13.8 Barg).

FEATURES

- High Stability:** High mass plug allows dampening of high frequency disturbances from inlet or outlet side of regulator.
- Trim Removal:** Easily removable trim from regulator while in-line.
- Adjustment Ease:** Adjusting knob for frequent set point changes.
- Wetted Materials Construction:** All metallic parts are SST. Unit is cleaned to Cashco Spec. #S-1576.
- Surface Finish:** Interior of body surface electro-polished to 32 micro-inch R_a finish with electro-polished exterior.

APPLICATIONS

Used in pharmaceutical industry in production of many health care products for both human and animal consumption. Widely applied for processed food production — candy, beverages, nutritional supplements and artificial sweeteners. May also be used in cosmetics production and specialty chemicals.

Would be found supporting fermenters, batching tanks, cookers, dryers and other similar equipment.

STANDARD/GENERAL SPECIFICATIONS

Body Size and Material: 1/2" (DN15)
Wrought Barstock; ASTM A479, Type 316L SST.

Body Connection: Standard - Sanitary "Tri-Clamp®".
Designed to seal against weld-type clamp liners per ISO 2852.

Spring Chamber Materials: Standard - Cast SST; ASTM A351, Grade CF3M.

Trim:

| PART | S1L | SET |
|---------------------------|---------------------------|---------------------------|
| Diaphragm | 302 SST | EPDM |
| Diaphragm Cover | - | TFE |
| Piston | 316L SST | 316L SST |
| Seat ¹ | 316L SST | TFE |
| Spring | 302 SST | 302 SST |
| Pusher Plate | 316L SST | 316L SST |
| Body Cap | 316L SST | 316L SST |
| Temperature Range °F (°C) | -20 to +400 (-29 to +205) | -20 to +300 (-29 to +149) |

¹The fixed portion of the seat is integral to the body. Indicated seat is the moving portion and is attached or integral with the piston.

NOTE: Cashco, Inc. does not recommend metal seated trim on any service where the flow will be dead ended down stream of the pressure reducing regulator. Use composition seat for dead end service.

Gasket/Seal: TFE diaphragm gasket; TFE O-ring at pusher plate location.

Operating Temperature: -20 to +400°F (-29° to +205°C)

Inlet Pressure: 600 psig (41.3 Barg) maximum

Range Springs & Maximum Pressure Drop: Standard: SST

| Range Spring | | Recommended Max. Pressure Drop | |
|--------------|------------|--------------------------------|--------|
| psig | (Barg) | psig | (Barg) |
| 5-30 | (.34-2.1) | 400 | (27.6) |
| 20-80 | (1.4-5.5) | 400 | (27.6) |
| 70-140 | (4.8-9.6) | 400 | (27.6) |
| 130-200 | (9.0-13.8) | 400 | (27.6) |

Cv's/Capacities: See Tables 1, 2, 3, and 4.

Cleaning: All units cleaned per Cashco Spec. #S-1576.

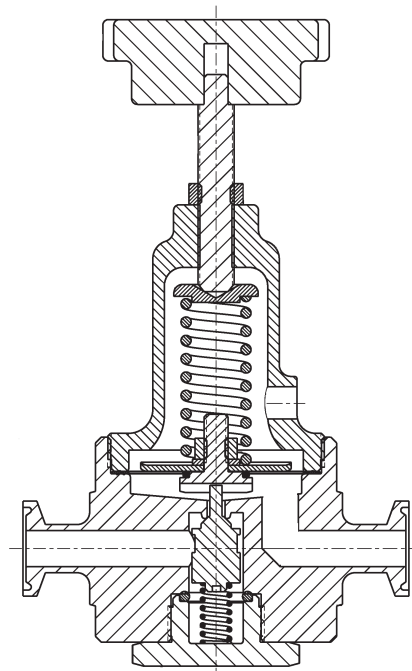

Figure 1: Metal Seat Design

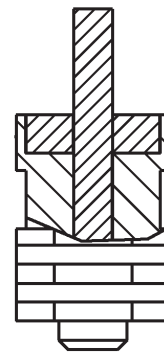

Figure 2: Composition Seat Design

TECHNICAL SPECIFICATIONS

TABLE 1
CAPACITY - Cv
(FL = 0.95)

| OUTLET (P2) PRESSURE (psig) | METAL DIAPHRAGM | | | COMPOSITION DIAPHRAGM | | |
|-----------------------------------|-----------------|-----|-----|-----------------------|-----|-----|
| | % DROOP | | | % DROOP | | |
| | 10% | 20% | 30% | 10% | 20% | 30% |
| 10 | .05 | .09 | .15 | .13 | .22 | .35 |
| 25 | .13 | .24 | .33 | .35 | .47 | .50 |
| 50 | .07 | .15 | .22 | .35 | .47 | .50 |
| 75 | .12 | .23 | .32 | .45 | .50 | .50 |
| 100 | .11 | .21 | .30 | .39 | .49 | .50 |
| 125 | .13 | .24 | .33 | .42 | .50 | .50 |
| 150 | .10 | .19 | .28 | .38 | .48 | .50 |
| 200 | .11 | .21 | .30 | .35 | .47 | .50 |

TABLE 2
WATER CAPACITY - GPM
S.G. = 1.0 T - 60°F FL = 0.95
Composition Diaphragm Only

| OUTLET FLOWING PRESSURE (psig) | INLET PRESSURE (psig) | 10% Droop | 20% Droop | 30% Droop | OUTLET FLOWING PRESSURE (psig) | INLET PRESSURE (psig) | 10% Droop | 20% Droop | 30% Droop |
|--------------------------------|-----------------------|-----------|-----------|-----------|--------------------------------|-----------------------|-----------|-----------|-----------|
| 5 | 50 | 0.9 | 1.5 | 2.3 | 35 | 50 | 1.5 | 1.9 | 1.9 |
| | 75 | 1.1 | 1.8 | 2.9 | | 75 | 2.5 | 3.1 | 3.2 |
| | 100 | 1.3 | 2.1 | 3.4 | | 100 | 3.1 | 4.0 | 4.0 |
| | 125 | 1.4 | 2.4 | 3.8 | | 125 | 3.7 | 4.6 | 4.7 |
| | 150 | 1.6 | 2.6 | 4.2 | | 150 | 4.2 | 5.3 | 5.4 |
| | 175 | 1.7 | 2.9 | 4.6 | | 175 | 4.6 | 5.8 | 5.9 |
| | 200 | 1.8 | 3.1 | 4.9 | | 200 | 5.0 | 6.3 | 6.4 |
| 10 | 50 | 2.2 | 3.0 | 3.2 | 50 | 75 | 1.9 | 2.4 | 2.5 |
| | 75 | 2.8 | 3.8 | 4.0 | | 100 | 2.7 | 3.4 | 3.5 |
| | 100 | 3.3 | 4.5 | 4.7 | | 125 | 3.3 | 4.2 | 4.3 |
| | 125 | 3.8 | 5.0 | 5.4 | | 150 | 3.8 | 4.8 | 5.0 |
| | 150 | 4.1 | 5.6 | 5.9 | | 175 | 4.2 | 5.4 | 5.6 |
| | 175 | 4.5 | 6.0 | 6.4 | | 200 | 4.7 | 5.9 | 6.1 |
| | 200 | 4.8 | 6.5 | 6.9 | | 100 | 1.8 | 2.4 | 2.5 |
| 15 | 50 | 2.1 | 2.8 | 3.0 | 75 | 125 | 2.5 | 3.3 | 3.5 |
| | 75 | 2.7 | 3.6 | 3.9 | | 150 | 3.0 | 4.1 | 4.3 |
| | 100 | 3.2 | 4.3 | 4.6 | | 175 | 3.5 | 4.7 | 5.0 |
| | 125 | 3.7 | 4.9 | 5.2 | | 200 | 3.9 | 5.3 | 5.6 |
| | 150 | 4.1 | 5.5 | 5.8 | 100 | 125 | 2.0 | 2.5 | 2.5 |
| | 175 | 4.4 | 5.9 | 6.3 | | 150 | 2.8 | 3.5 | 3.5 |
| | 200 | 4.8 | 6.4 | 6.8 | | 175 | 3.5 | 4.2 | 4.3 |
| 25 | 50 | 2.3 | 2.5 | 2.5 | 200 | 200 | 4.0 | 4.9 | 5.0 |
| | 75 | 3.2 | 3.5 | 3.5 | | 125 | 150 | 2.1 | 2.5 |
| | 100 | 3.9 | 4.3 | 4.3 | 175 | | 3.0 | 3.5 | 3.5 |
| | 125 | 4.5 | 5.0 | 5.0 | 200 | | 3.6 | 4.3 | 4.3 |
| | 150 | 5.0 | 5.6 | 5.6 | | | | | |
| | 175 | 5.5 | 6.1 | 6.1 | | | | | |
| | 200 | 6.0 | 6.6 | 6.6 | | | | | |

TABLE 3
AIR CAPACITY - SCFH
S.G. = 1.0 T - 60°F FL - 0.95
1/2" Size - Composition Diaphragm Only

| OUTLET FLOWING PRESSURE (psig) | INLET PRESSURE (psig) | 10% Droop | 20% Droop | 30% Droop | OUTLET FLOWING PRESSURE (psig) | INLET PRESSURE (psig) | 10% Droop | 20% Droop | 30% Droop |
|--------------------------------|-----------------------|-----------|-----------|-----------|--------------------------------|-----------------------|-----------|-----------|-----------|
| 5 | 25 | 200 | 300 | 500 | 35 | 50 | 700 | 900 | 900 |
| | 50 | 300 | 500 | 800 | | 75 | 1200 | 1500 | 1500 |
| | 75 | 400 | 700 | 1100 | | 100 | 1600 | 2000 | 2000 |
| | 100 | 500 | 900 | 1400 | | 150 | 2300 | 2900 | 2900 |
| | 150 | 800 | 1300 | 2000 | | 200 | 3000 | 3700 | 3800 |
| | 200 | 1000 | 1700 | 2700 | | 300 | 4400 | 5500 | 5600 |
| | 300 | 1500 | 2500 | 3900 | | 400 | 5800 | 7200 | 7400 |
| | 400 | 1900 | 3200 | 5200 | | 75 | 1000 | 1300 | 1300 |
| 10 | 25 | 500 | 600 | 700 | 50 | 100 | 1500 | 1800 | 1900 |
| | 50 | 800 | 1100 | 1100 | | 150 | 2200 | 2800 | 2900 |
| | 75 | 1100 | 1500 | 1600 | | 200 | 2900 | 3600 | 3800 |
| | 100 | 1400 | 1900 | 2000 | | 300 | 4200 | 5400 | 5600 |
| | 150 | 2000 | 2700 | 2900 | | 400 | 5600 | 7100 | 7400 |
| | 200 | 2700 | 3600 | 3800 | | 100 | 1100 | 1400 | 1500 |
| | 300 | 3900 | 5300 | 5600 | | 150 | 1900 | 2600 | 2700 |
| | 400 | 5200 | 6900 | 7400 | | 200 | 2600 | 3500 | 3700 |
| 15 | 25 | 400 | 600 | 600 | 75 | 300 | 3600 | 5200 | 5600 |
| | 50 | 800 | 1100 | 1100 | | 400 | 5200 | 6900 | 7400 |
| | 75 | 1100 | 1500 | 1600 | | 150 | 2000 | 2400 | 2400 |
| | 100 | 1400 | 1900 | 2000 | | 200 | 2900 | 3500 | 3600 |
| | 150 | 2000 | 2700 | 2900 | | 300 | 4400 | 5400 | 5500 |
| | 200 | 2700 | 3600 | 3800 | | 400 | 5900 | 7200 | 7400 |
| | 300 | 3900 | 5300 | 5600 | | 500 | 7300 | 9000 | 9200 |
| | 400 | 5200 | 6900 | 7400 | | 200 | 2400 | 2900 | 2900 |
| 25 | 50 | 1100 | 1100 | 1100 | 150 | 300 | 4400 | 5300 | 5300 |
| | 75 | 1400 | 1600 | 1600 | | 400 | 6100 | 7200 | 7200 |
| | 100 | 1800 | 2000 | 2000 | | 500 | 7700 | 9100 | 9100 |
| | 150 | 2600 | 2900 | 2900 | | 300 | 3300 | 4400 | 4700 |
| | 200 | 3400 | 3800 | 3800 | | 400 | 4900 | 6600 | 6900 |
| | 300 | 5000 | 5600 | 5600 | | 500 | 6300 | 8500 | 9000 |
| | 400 | 6600 | 7400 | 7400 | | | | | |

TABLE 4
STEAM - LBS/HR
S.G. = Actual T = Saturated FL = 0.95
1/2" Size - Metal Diaphragm Only

| OUTLET FLOWING PRESSURE (psig) | INLET PRESSURE (psig) | 10% Droop | 20% Droop | 30% Droop | OUTLET FLOWING PRESSURE (psig) | INLET PRESSURE (psig) | 10% Droop | 20% Droop | 30% Droop | |
|--------------------------------|-----------------------|-----------|-----------|-----------|--------------------------------|-----------------------|-----------|-----------|-----------|-----|
| 5 | 25 | 2 | 3 | 5 | 35 | 50 | 6 | 10 | 15 | |
| | 50 | 3 | 6 | 9 | | 75 | 10 | 17 | 26 | |
| | 75 | 5 | 8 | 13 | | 100 | 14 | 23 | 35 | |
| | 100 | 6 | 10 | 16 | | 125 | 17 | 29 | 43 | |
| | 125 | 7 | 12 | 20 | | 150 | 20 | 34 | 51 | |
| | 150 | 9 | 15 | 23 | | 175 | 23 | 39 | 58 | |
| | 175 | 10 | 17 | 27 | | 200 | 26 | 45 | 67 | |
| | 200 | 11 | 19 | 30 | | 240 | 31 | 53 | 80 | |
| | 240 | 13 | 22 | 36 | | 50 | 75 | 10 | 21 | 30 |
| 10 | 25 | 4 | 5 | 8 | 100 | | 15 | 31 | 44 | |
| | 50 | 7 | 8 | 14 | 125 | | 19 | 40 | 56 | |
| | 75 | 9 | 12 | 20 | 150 | | 22 | 47 | 67 | |
| | 100 | 12 | 15 | 25 | 175 | | 26 | 55 | 77 | |
| | 125 | 15 | 19 | 31 | 200 | | 29 | 62 | 88 | |
| | 150 | 17 | 22 | 36 | 240 | | 35 | 74 | 104 | |
| | 175 | 20 | 25 | 42 | 75 | | 100 | 17 | 32 | 45 |
| | 200 | 23 | 28 | 47 | | | 125 | 24 | 46 | 65 |
| | 240 | 27 | 33 | 56 | | 150 | 30 | 58 | 82 | |
| 15 | 25 | 4 | 10 | 14 | | 175 | 36 | 69 | 97 | |
| | 50 | 8 | 19 | 28 | | 200 | 41 | 79 | 111 | |
| | 75 | 12 | 27 | 39 | | 240 | 50 | 95 | 133 | |
| | 100 | 15 | 35 | 50 | | 100 | 125 | 16 | 36 | 50 |
| | 125 | 19 | 43 | 62 | | | 150 | 23 | 51 | 72 |
| | 150 | 22 | 51 | 73 | | | 175 | 29 | 64 | 90 |
| | 175 | 25 | 58 | 83 | 200 | | 34 | 76 | 107 | |
| | 200 | 28 | 66 | 94 | 240 | | 42 | 93 | 130 | |
| | 240 | 33 | 78 | 111 | 150 | | 175 | 19 | 37 | 53 |
| 25 | 50 | 13 | 25 | 30 | | | 200 | 27 | 52 | 76 |
| | 75 | 20 | 38 | 46 | | | 240 | 38 | 72 | 104 |
| | 100 | 26 | 49 | 59 | 200 | | 240 | 33 | 60 | 83 |
| | 125 | 31 | 60 | 72 | | | | | | |
| | 150 | 37 | 71 | 85 | | | | | | |
| | 175 | 43 | 83 | 100 | | | | | | |
| | 200 | 49 | 94 | 113 | | | | | | |
| | 240 | 58 | 111 | 134 | | | | | | |

**TABLE 5
OUTLET PRESSURE LIMIT-
SAFETY RELIEF VALVE SIZING & SETPOINT**

| RANGE SPRING (psig) | DIAPHRAGM MATERIAL | EMERGENCY ¹ OVER-PRESSURE (psig) | MAXIMUM Cv WITH VALVE PLUG WIDE OPEN |
|--------------------------------------------------------------------------------------------------------------------------------------------------------------------------------------------------------------------------------------------------------------------------------|--------------------|---------------------------------------------|--------------------------------------|
| 5-30, 20-80, 70-140, 130-200 | ALL | 1.5 x UVRS ² | 0.5 |
| ¹ "Emergency Over-Pressure" is defined as the level of pressure, which if exceeded, may cause internal mechanical damage. ² UVRS - "Upper Value of Range Spring"; i.e. 130-200 psig (9 -13.8 Barg) range spring, value would be 200 psig (13.8 Barg). | | | |

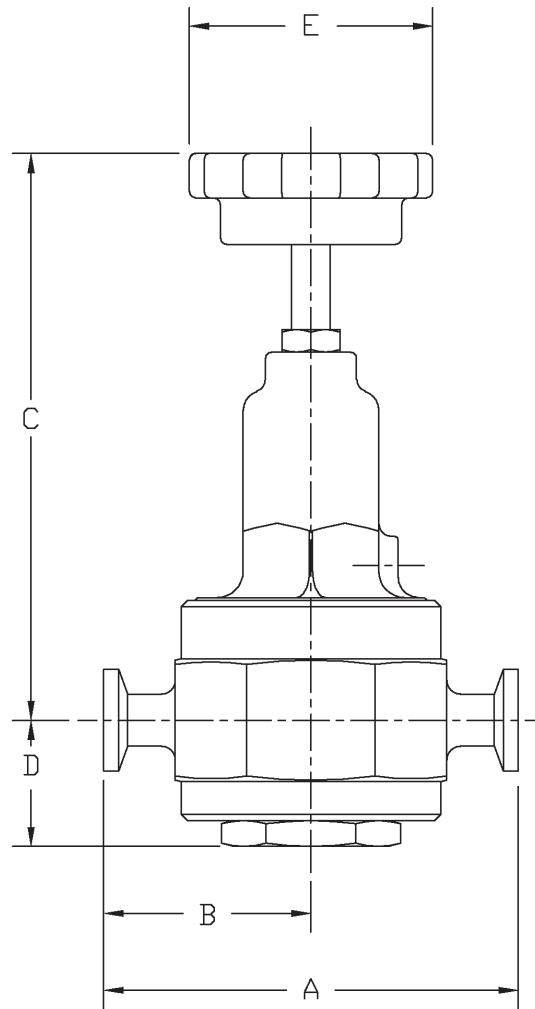

Weight = 4 Lbs.
(1.82 kgs)

DIMENSIONS AND WEIGHTS

| Units in. (mm) | | | | |
|----------------|-----------|------------|-----------|-----------|
| A | B | C | D | E |
| 4.00 (102) | 2.00 (51) | 5.47 (139) | 1.22 (31) | 2.35 (60) |

NOTES

The contents of this publication are presented for informational purposes only, and while every effort has been made to ensure their accuracy, they are not to be construed as warranties or guarantees, express or implied, regarding the products or services described herein or their use or applicability. We reserve the right to modify or improve the designs or specifications of such product at any time without notice. Cashco, Inc. does not assume responsibility for the selection, use or maintenance of any product. Responsibility for proper selection, use and maintenance of any Cashco, Inc. product remains solely with the purchaser.

MODEL 5381 PRODUCT CODE 03/08/16

FOR THE FOOD AND PHARMACEUTICAL INDUSTRY

An "X" in POS 12 followed by a 5-digit control number overrides remaining selections.

MS **4** - **A** POS 6 & 7 **7** - **1** POS 11 POS 12 POS 13 **0000C**

| POSITION 6 & 7 – TRIM DESIGNATION NUMBERS | |
|-------------------------------------------|------|
| Desig. | CODE |
| S1L* | L1 |
| SET | ST |

* Trim utilized on steam service only.

| POSITION 11 – RANGE SPRINGS | | |
|-----------------------------|------------|------|
| SST Range Spring | | CODE |
| psig | (Barg) | |
| 5-30 | (.34-2.1) | A |
| 20-80 | (1.4-5.5) | B |
| 70-140 | (4.8-9.7) | C |
| 130-200 | (9.0-13.8) | D |

| POSITION 12 - OPTIONS | | |
|----------------------------------------------------------------------|--------|------|
| Description | Option | CODE |
| Wetted Parts Cert 'U' (USP). | Std | 6 |
| For Special Construction Contact Cashco for Special Product Code. | SPQ | X |

| POSITION 13 - OPTIONS | | |
|-----------------------------------|--------|------|
| Description | Option | CODE |
| #32Ra Micro-inch Internal finish. | Std | 0 |
| #20Ra Micro-inch Internal Finish. | | P |

Cashco, Inc.
P.O. Box 6
Ellisworth, KS 67439-0006
PH (785) 472-4461
Fax. # (785) 472-3539
www.cashco.com
email: sales@cashco.com
Printed in U.S.A. 5381-TB

Cashco GmbH
Handwerkerstrasse 15
15366 Hoppegarten, Germany
PH +49 3342 30968 0
Fax. No. +49 3342 30968 29
www.cashco.com
email: germany@cashco.com

Cashco do Brasil, Ltda.
Al.Venus, 340
Indaiatuba - Sao Paulo, Brazil
PH +55 11 99677 7177
Fax. No.
www.cashco.com
email: brazil@cashco.com