



ISO Registered Company

MODELS C27 - C53

SPRING/DIAPHRAGM LINEAR PNEUMATIC ACTUATORS

SECTION I

I. DESCRIPTION AND SCOPE

Actuator models C27 and C53 are multi-spring, single acting, spring opposed, linear actuators used with Cashco sliding stem (linear), globe-style control valves. The "R" denotes "reverse" acting arrangement; the "D" denotes "direct" acting arrangement and are reversible in the field.

"D" = Direct action; on increasing air loading pressure, the actuator stem extends. Fail-safe position is with the stem retracted.

"R" = Reverse action; on increasing air loading pressure, the actuator stem retracts. Fail-safe position is with the stem extended.

When coupled with a globe-style control valve with pushdown to close action, a "D"- direct acting actuator will provide valve "fail open" action; "D" = ATC-FO. When coupled with an "R" - reverse acting actuator, will provide valve "fail closed" action; "R" = ATO-FC.

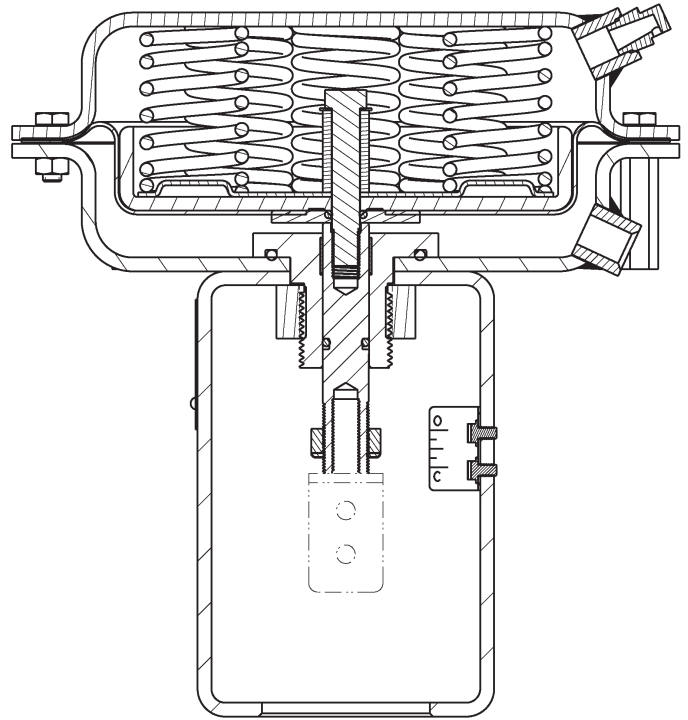

Shown w/ATO-FC Action

SECTION II

II. REFERENCES

Refer to the Control Valve Technical Bulletin this actuator is unitized with for complete technical specifications.

Refer to following Installation, Operation & Maintenance Manuals (IOM's) for other devices that maybe mounted to C27-C53 actuators:

Positioners: P/P: P5 or I/P: D20 or D3 go to <http://www.pmv.nu/products.aspx?pathlocator>
PS2 I/P: http://www.automation.siemens.com/sc-static/catalogs/catalog/pi/fi01/en/fi01_en_kap05.pdf

ABBREVIATIONS

- ATO-FC Air-to-Open, Fail Close
- ATC-FO Air-to-Close, Fail Open
- CCW Counter Clockwise
- CW Clockwise
- D or DIR Direct Acting
- R or REV.. Reverse Acting
- IAS Instrument Air Supply
- SIG Output Signal from Instrument
- LOAD Positioner Output Air Pressure
- V Vent

SECTION III

III. INSTALLATION

A. Orientation:

1. Recommended actuator major axis orientation with any model of Cashco control valve body, is upwards in a horizontal pipe.
2. Actuator axis may be horizontal when valve is in a vertical pipe.
3. Outdoors, all installations must be oriented any angle from horizontal-to-vertical.
4. Models C27 and C53 actuators are not recommended for installation oriented downwards in either "D" or "R" action.
5. In no case is additional weight to be applied to the actuator when installed in an orientation other than vertical; i.e. the valve is unsafe as a "step" to support personnel.

B. Air Supply:

1. Recommendation is that a desiccant dried, instrument quality air supply be used. Such a supply is recommended for outdoors installations, and is required in areas of freezing weather conditions.
2. If air supply contains moisture and/or lubricating oil, the air should be filtered with a coalescing type of filter prior to use in stroking the actuator.
3. Failure to remove moisture will cause corrosion to internals of casings (1,2).
4. Connections for the air supply are 1/4" female NPT. A suitable pipe thread sealant is recommended to be used when installing the pipe or tube fitting. Exhibit care to prevent the sealant from getting inside the tube/pipe.

SECTION IV

IV. MAINTENANCE

A. General:

1. Hereafter, all maintenance, disassembly, etc., is assumed to be done in an indoor shop.
2. An actuator assembly (AA) is unitized with a body assembly (BA). Reference should be made to the body IOM for instructions about the specified body assembly (BA) utilized with the actuator.
3. Where the body is not being removed from the actuator, special care **MUST** be exhibited to prevent valve stem rotation during any disassembly or reassemble for all valve models. Following this procedure will ensure not damaging seating surfaces.
4. Remove instrument tubing, airset, positioner, and any other accessory that maybe mounted on the control valve unit (AA, BA).
5. All indicated Item Numbers that are with respect to body (BA) IOM will be in parenthesis and underscored; i.e. (20); the same is true for positioner parts. All Item Numbers that are with respect to this manual are not underscored; i.e. (19).

B. Diaphragm Removal/Replacement:

NOTE: Actuator (AA) must be separated from the body (BA) in order to replace O-rings (15, 16 & 17) and diaphragm (7). Refer to specified body (BA) IOM for instructions to remove actuator (AA).

NOTE: If actuator (AA) has Handwheel refer to Step E and remove.

1. Secure the yoke (3) in a vise. Orient with the (AA) upwards.
2. All air pressure must be released from the actuator casings (1,2).
3. Take note of alignment of supply ports on top and bottom cases (1,2); used to assist with orientation when actuator is re-assembled.



WARNING

SPRINGS UNDER COMPRESSION! To relax spring compression remove case bolting equally in an alternating pattern. Ensure that all "short" bolting is removed first.

4. Loosen all flange bolting (18,19,20,21) two revolutions. Pry apart the casings (1,2) if “stuck” together.
5. In one revolution increments loosen all opposing nuts (20, 21) until the short bolting (18, 20) disengages and can be removed. Continue loosening long nuts (21) in the alternating, one revolution pattern ensuring that the casings (1,2) are being “pushed apart”, until the long bolting (19, 21) is disengaged and removed.

For Air-to-Close Construction:

6. Remove top case (1). Secure the flats on the lower end of the actuator stem (6) with a wrench. With a second wrench rotate the upstop flex nut (52) CCW and remove. **Note:** *Item (52) not used if actuator has handwheel.*
7. Re-secure the flats on stem and with a 9/16” socket wrench rotate bolt (12) CCW to remove.
8. Lift out lock washer (22), diaphragm washer (14) and O-ring (15). Remove diaphragm (7).

NOTE: *To replace stem bushing (39) and o-ring (17) refer to Step F.*

9. Install new diaphragm (7) over the diaphragm plate (8), convoluted side down. Align bolt holes in diaphragm with holes in lower case.
10. Install new o-ring (15) and reposition washers (14 & 22) on top of diaphragm.
11. Apply Loc-tite #242 or equal to stem bolt (12) threads, tighten stem bolt (12) to actuator stem (6) with 35 ft-lbs. torque.
12. Place upper case on lower case align top and bottom cases (1,2) per B.3 previous. Install long bolting (19) and nuts (21) equally spaced around the bolt circle - finger tighten.
13. Install remaining short bolts (18) and nuts (20). Torque all bolting to 75 in-lbs.
14. Thread upstop flex nut (52) [coupling assembly (33) for handwheel option] onto the actuator stem (6) and engage until just past stem flats. **NOTE:** *Upstop position cannot be set until actuator is mounted on the body and the bench range is set.*

For Air-to-Open Construction:

15. Remove top case (1). Place matchmarks on spring plate (9) to mark location of the springs (10). Remove springs (10).
16. Rotate upstop flex nut (52) CCW and remove. **Note:** *Item (52) not used if actuator has handwheel assembly.*
17. Secure the flats on stem (6) and with a 9/16” socket wrench rotate bolt (12) CCW to remove.
18. Remove lock washer (22) and spacer (5).
19. Remove spring plate (9) diaphragm plate (8), diaphragm (7), o-ring (15) and diaphragm washer (14).
20. Grasp stem (6) with hand and pull down thru the attachment hub (4). Remove o-ring (17) from stem (6). Lubricate new o-ring (17) with Lubri-plate or equivalent and install on stem (6).
21. From the top of the attachment hub (4) extract the stem bushing (39). Install new bushing.
22. Grasp stem (6) with hand and from below the lower case (2) push the stem up thru the attachment hub (4) until the bottom end of the stem aligns with the “C” close mark on the indicator plate (23).
23. Reposition diaphragm washer (14) “o-ring side up” and new o-ring (15) on top of attachment hub (4).
24. Place the diaphragm plate (8) inside the diaphragm (7) and carefully place both on the diaphragm washer (14). Align bolt holes in diaphragm with holes in lower case.
25. Align the spring plate (9) and stem spacer (5) over the center hole of the diaphragm plate (8).
26. Apply Loc-tite #242 to stem bolt (12) threads and insert down through stacked parts and rotate CW to engage threaded end of stem (6). Tighten stem bolt (12) to actuator stem (6) with 35 ft-lbs. torque.
27. Place springs (10) equally spaced around the spring plate (9). See Step 15 previous for matchmarks.

28. Refer to B.3 previous, align top and bottom cases (1,2). Install long bolting (19) and nuts (21) equally spaced around the bolt circle - finger tight.
29. Install remaining short bolts (18) and nuts (20). Torque all bolting to 75 in-lbs.
30. Thread upstop flex nut (52) [coupling assembly (33) for handwheel option] CW onto the actuator stem (6) and engage until just past stem flats. **NOTE:** *Upstop position cannot be set until actuator is mounted on the body and the bench range is set.*

C. Changing Action from Direct to Reverse; i.e. From ATC to ATO.

NOTE: *Not necessary to remove actuator assembly from body assembly, unless supplied with Handwheel Assembly.*

1. Follow steps from B.1 thru B.5 then continue as follows.

NOTE: DO NOT *rotate actuator stem (6) or body stem.*

2. Secure both stem jam nuts with wrenches and rotate the lower nut first down to thread base of the stem, followed by the upper nut.
3. Secure the flats on the lower end of the actuator stem (6) with a wrench. With a second wrench rotate the upstop flex nut (52) CCW 5 revolutions. (Required to help release spring preload when stem bolt (12) is removed.)
4. Remove top case (1). Re-secure the flats on stem and with a 9/16" socket wrench rotate bolt (12) CCW and remove.
5. Lift out lock washer (22), diaphragm washer (14) and O-ring (15). Remove diaphragm (7).
6. Remove diaphragm plate (8), spring plate (9), stem spacer (5) and springs (10).
7. With hand pressure - push stem (6) down to where bottom of stem (6) aligns with the "C" close mark on the indicator plate (23).

NOTE: DO NOT *rotate actuator stem (6) or body stem while plug is touching the seat surface.*

8. Re-assemble by placing diaphragm washer (14) "o-ring side up" and new o-ring (15) on attachment hub (4).

9. Place the diaphragm plate (8) inside the diaphragm (7) and carefully center both on the diaphragm washer (14). Align bolt holes in diaphragm with holes in lower case.
10. Align center holes in the spring plate (9) and stem spacer (5) with the center hole of the diaphragm plate (8).
11. Apply Loc-tite #242 to stem bolt (12) threads and insert down through stacked parts. Rotate CW to engage threaded end of stem (6). Secure the flats on the lower end of the actuator stem (6) with a wrench. Tighten stem bolt (12) to actuator stem (6) with 35 ft-lbs. torque.

NOTE: DO NOT *rotate actuator stem (6) or body stem while plug is touching the seat surface.*

12. Place springs (10) equally spaced around the spring plate (9).
13. Refer to B.3 previous, align top and bottom cases (1,2). Install long bolting (19) and nuts (21) equally spaced around the bolt circle - finger tight.
14. Install remaining short bolts (18) and nuts (20). Torque all bolting to 75 in-lbs.
15. Rotate upstop flex nut (52) CW up the actuator stem (6) until just past stem flats. **NOTE:** *Upstop position cannot be set until the bench range is set.*
16. Lift indicating washer up to bottom of stem (6) and thread both jam nuts up secure underneath the indicating washer.

D. Changing Action from Reverse to Direct; i.e. From ATO to ATC.

NOTE: *Not necessary to remove actuator assembly from body assembly, unless supplied with Handwheel Assembly.*

1. Follow steps from B.1 thru B.5, then continue as follows.
2. Remove top case (1) and springs (10).
3. Secure the flats on stem (6) and with a 9/16" socket wrench rotate bolt (12) CCW to remove.

NOTE: DO NOT *rotate actuator stem(6) or body stem while plug is touching the seat surface.*

4. Remove lock washer (22) and stem spacer (5).
5. Remove spring plate (9) diaphragm plate (8), diaphragm (7), o-ring (15) and diaphragm washer (14).
6. Grasp stem (6) with hand and push upwards to where indicating washer aligns with the "O" open mark on the indicator plate (23).
7. Place springs (10) equally spaced in bottom case (2) around the attachment hub (4).
8. Place stem spacer (5) on top of stem (6). Carefully position spring plate (9) over top the tops of the springs and spacer. Ensure the springs, spacer and spring plate are properly engaged.
9. Carefully set the diaphragm plate (8) on top of the spring plate (9).
10. Install diaphragm (7) over the diaphragm plate (8) and align with bolt holes in case (2). Insert new o-ring (15) into groove in the diaphragm washer (14).
11. Position diaphragm washer (14) "o-ring side down" and lock washer (22) on top of diaphragm (7).
12. Apply Loc-tite #242 to stem bolt (12) threads and insert down through stacked parts, rotate CW to engage threaded end of stem (6). Secure the flats on the lower end of the actuator stem (6) with a wrench. Tighten stem bolt (12) to actuator stem (6) with 35 ft-lbs. torque.

NOTE: DO NOT rotate actuator stem (6) or body stem while plug is touching the seat surface.

13. Refer to B.3 previous, align top and bottom cases (1,2). Install long bolting (19) and nuts (21) equally spaced around the bolt circle - finger tight.
14. Install remaining short bolts (18) and nuts (20). Torque all bolting to 75 in-lbs.
15. Rotate upstop flex nut (52) to align just past the flats on the stem (6). ***NOTE: Upstop position cannot be set until the bench range is set.***

E. To Remove Handwheel Assembly.

For Air to Close Construction:

1. Rotate locknut (36) CCW two revolutions. Rotate handwheel (31.2) CCW until it spins freely.
2. With hammer and pointed punch, tap the spring pin (35) out of the handwheel and remove handwheel.
3. Remove nuts (38) and lock washer (48) from cap screws (37). **DO NOT** let bracket assembly fall as cap screws are removed. Lift bracket assembly up such that the opening of the pivot brackets (26) slip over the posts on the coupling assembly (33). Set bracket assembly aside.
4. Provide a temporary air supply with an in-line adjustable airset regulator to the actuator connection.
5. Pressurize the actuator to a pressure level 2-3 psig (0.1-0.2 Barg) above the lower pressure level of the bench setting; i.e. for a 5-15 psig (.34 -1.0 Barg) range, set pressure at 7-8 psig (0.48-0.55 Barg).
6. Rotate the coupling assembly (33) CCW to remove and release all air pressure from actuator.

Return to Section IV. B. Step 1.

For Air to Open Construction:

1. Rotate locknut (36) CCW up to base of handwheel. Rotate handwheel (31.2) CW until it spins freely.
2. With hammer and pointed punch, tap the spring pin (35) out of the handwheel and remove handwheel.
3. Remove nuts (38) and lock washer (48) from cap screws (37). **DO NOT** let bracket assembly fall as cap screws are removed. Lift bracket assembly up such that the opening of the pivot brackets (26) slip over the posts on the coupling assembly (33). Set bracket assembly aside.
4. Rotate coupling assembly (33) CCW to remove.

Return to Section IV. B. Step 1.

**F. Bushing & O-ring Replacement ATC only.
(Extension of IV. B. Steps 1 - 8.)**

1. Remove diaphragm plate (8), spring plate (9) and stem spacer (5).
2. Place matchmarks on lower case (2) to mark location of the springs (10). Remove springs (10).
3. Grasp stem (6) with hand and pull down thru attachment hub (4). Remove o-ring (17) from stem (6). Lubricate new o-ring (17) with Lubri-plate or equivalent and install on stem (6).
4. From the top of the attachment hub (4) extract the stem bushing (39). Install new bushing.
5. Grasp stem (6) with hand and from below the lower case (2) push the stem back up thru the attachment hub (4) until the bottom end of the stem aligns with the "O" open mark on the indicator plate (23).
6. Reset springs (10) equally spaced around the lower case (2). See Step 2 previous for matchmarks.
7. Place stem spacer (5) on top of stem (6). Carefully position the spring plate (9) over the tops of the springs and spacer. Make sure the springs, spacer and spring plate are properly engaged.
8. Carefully set the diaphragm plate (8) on top of the spring plate (9).
9. Return to Section IV. B. Step 9.

SECTION V

V. TROUBLE SHOOTING GUIDE

NOTE: Cashco, Inc. recommends that if the casings are unbolted, the diaphragm, o-ring and TFE tape guide bushing should always be replaced.

1. Air Leakage; Reverse action units. Diaphragm removal/replacement per Section IV. MAINTENANCE in its entirety.

Symptom	Cause-Remedy
A. Leakage at diaphragm-to-lower casing flange or thru vent plug.	A1. Overpressure. Check source of air supply and determine if pressure is greater than indicated in Technical Bulletin; reset airset pressure as required. A2. Tighten flange bolting. A3. Faulty seal at stem-diaphragm-seal joint. Remove upper case - diaphragm. Install new o-ring (15).
B. Leakage from around stem and attachment hub.	B. Replace O-ring (17).

2. Air Leakage; Direct action units. Diaphragm removal/replacement per Section IV. MAINTENANCE in its entirety.

Symptom	Cause-Remedy
A. Leakage at diaphragm-to-upper casing joint or thru vent plug.	A1. Overpressure. Check source of air supply and determine if pressure is greater than indicated in Technical Bulletin; reset airset pressure as required. A2. Tighten flange bolting. A3. Faulty seal at stem-diaphragm-seal joint. Remove upper case - diaphragm washer. Install new o-ring (15).

3. Unstable stroking.

Symptom	Cause-Remedy
A. Intermittent screeching noise, jumpy motion; positioner/controller loading stable	A1. Excessive valve packing friction. Maintain valve packing per valve instructions. A2. Misalignment of valve stem-to-actuator stem; realign per valve instructions. A3. Excessive valve guide wear. Maintain valve per valve instructions. A4. Flow induced instability thru valve. Stabilize A5. Install high range spring in actuator; i.e. increase bench setting level.
B. Positioner output unstable; positioner input signal stable.	B1. Refer to the positioner IOM B2. Reduce positioner gain. B3. Re-calibrate positioner.
C. Controller output signal unstable.	C1. Stabilize controller by increasing proportional band, adding reset, adding rate, or combinations of all. C2. Unstable process. Snub process if able. Stabilize process.

4. Actuator can not deliver full stroke.

Symptom	Cause-Remedy
<p>A. Valve can not fully close for "Direct Action-ATC-FO" arrangement; or valve can not fully open for "Reverse Action-ATO-FC" arrangement.</p>	<p>A1. Insufficient air supply pressure. Check Technical Bulletin for proper air supply pressure. A2. Manual handwheel out of "neutral" position. A3. If equipped with a pneumatic positioner, positioner maybe in "bypass" mode. A4. Excessive pressure drop. Check technical bulletin of control valve for maximum allowable ΔP. A5. Bench range not properly calibrated. Check calibration or stem overall length and re-calibrate per valve instructions. Restriction in air supply line limiting volume available A6. Restriction in valve. Gain access to the valve's internals A7. for any debris.</p>
<p>B. Valve can not fully open for "Direct Action-ATC-FO" arrangement; or valve can not fully close for "Reverse Action-ATO-FC" arrangement.</p>	<p>B1. Insufficient air supply pressure. Check Technical Bulletin for proper air supply pressure. B2. Manual handwheel out of "neutral" position. B3. If equipped with a pneumatic positioner, positioner maybe in "bypass" mode. B4. Excessive pressure drop. Check technical bulletin of control valve for maximum allowable ΔP. B5. Bench range not properly calibrated. Check calibration or stem overall length and re-calibrate per valve instructions. Restriction in air supply line limiting volume available B6. Restriction in valve. Gain access to the valve's internals B7. for any debris.</p>

SECTION VI

VI. ORDERING INFORMATION NEW REPLACEMENT UNIT vs PARTS "KIT" FOR FIELD REPAIR

To obtain a quotation or place an order, please retrieve the Serial Number and Product Code that was stamped on the metal name plate and attached to the unit. This information can also be found on the Bill of Material ("BOM"), a parts list that was provided when unit was originally shipped. (Serial Number typically 6 digits). Product Code typical format as follows: (last digit is alpha character that reflects revision level for the product).

□□□□ - □□□□ 7 - □□□□□□□□□□□□

NEW REPLACEMENT UNIT:

Contact your local Cashco, Inc., Sales Representative with the Serial Number and Product code. With this information they can provide a quotation for a new unit including a complete description, price and availability.

PARTS "KIT" for FIELD REPAIR:

Contact your local Cashco, Inc., Sales Representative with the Serial Number and Product code. Identify the parts and the quantity required to repair the unit from the "BOM" sheet that was provided when unit was originally shipped.



CAUTION

Do not attempt to alter the original construction of any unit without assistance and approval from the factory. All purposed changes will require a new name plate with appropriate ratings and new product code to accommodate the recommended part(s) changes.

NOTE: *Those part numbers that have a quantity indicated under "Spare Parts" in column "A" reflect minimum parts required for inspection and rebuild, - "Soft Goods Kit". Those in column "B" include minimum trim replacement parts needed plus those "Soft Goods" parts from column "A".*

If the "BOM" is not available, refer to the cross-sectional drawings included in this manual for part identification and selection.

A Local Sales Representative will provide quotation for appropriate Kit Number, Price and Availability.

The contents of this publication are presented for informational purposes only, and while every effort has been made to ensure their accuracy, they are not to be construed as warranties or guarantees, express or implied, regarding the products or services described herein or their use or applicability. We reserve the right to modify or improve the designs or specifications of such product at any time without notice. Cashco, Inc. does not assume responsibility for the selection, use or maintenance of any product. Responsibility for proper selection, use and maintenance of any Cashco, Inc. product remains solely with the purchaser.

C27 Actuator ATC - FO Action

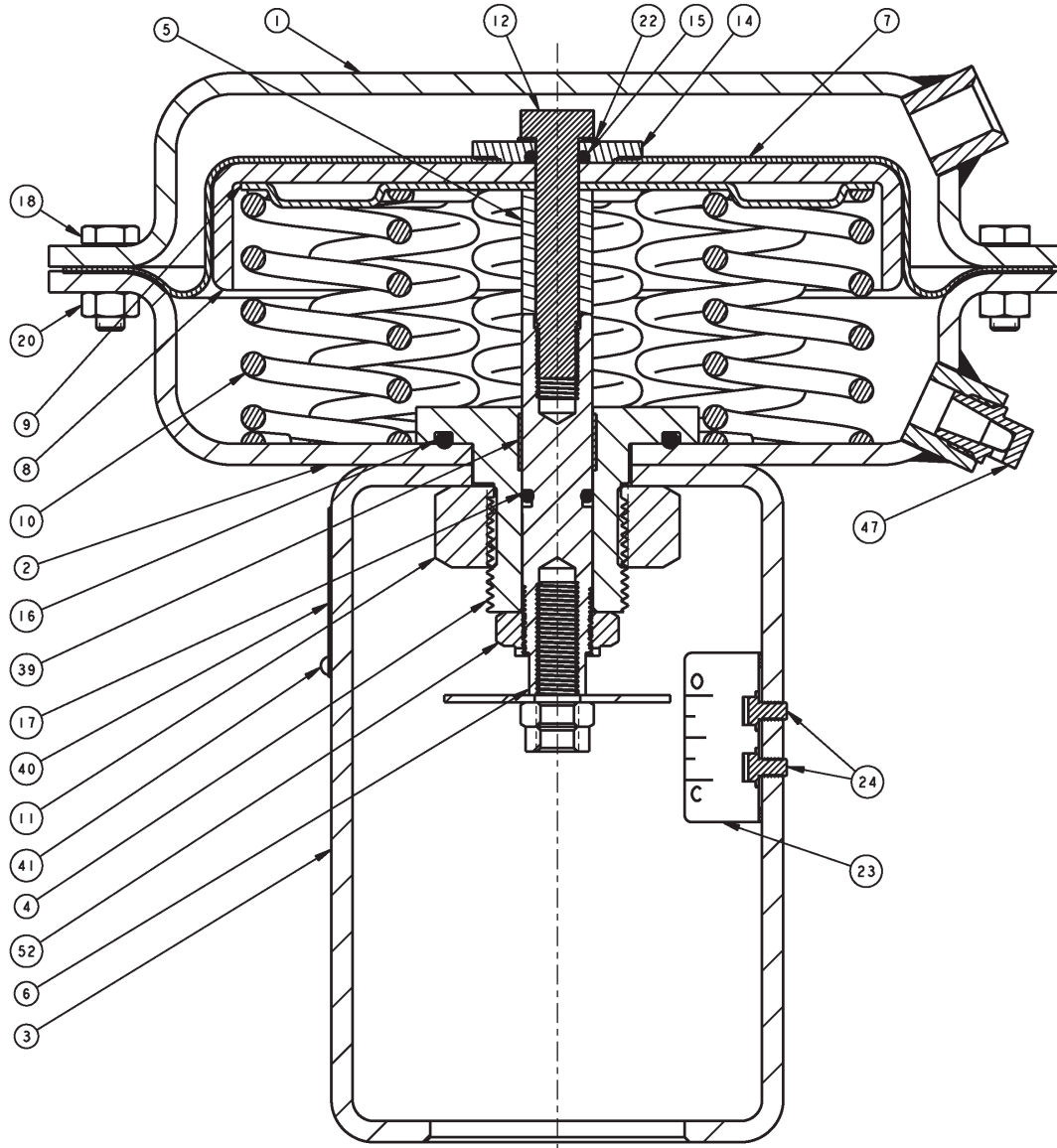

<u>Item No.</u>	<u>Description</u>
-----------------	--------------------

1	Case - Top
2	Case - Bottom
3	Yoke
4	Attachment Hub
5	Stem Spacer
6	Stem
7	Diaphragm ‡
8	Diaphragm Plate
9	Spring Plate
10	Spring
11	Hub Nut
12	Stem Bolt
14	Diaphragm Washer
15	Diaphragm Washer O-ring ‡
16	Attachment Hub O-ring ‡
17	Stem O-ring ‡

<u>Item No.</u>	<u>Description</u>
-----------------	--------------------

18	Case Bolts - Short
20	Case Nut - Short
22	Stem Lock Washer
23	Indicator Plate
24	Indicator Plate Screw
39	Stem Teflon Bushing ‡
40	Name Plate
41	Drive Screw
47	Vent Plug
52	Stem Stop Nut

Not Shown

19	Case Bolts - Long
21	Case Nuts - Long
49	Warning Plate (Item number for Indicating Washer is unique to Model)
‡	Recommended replacement parts.

C27 Actuator ATO - FC Action

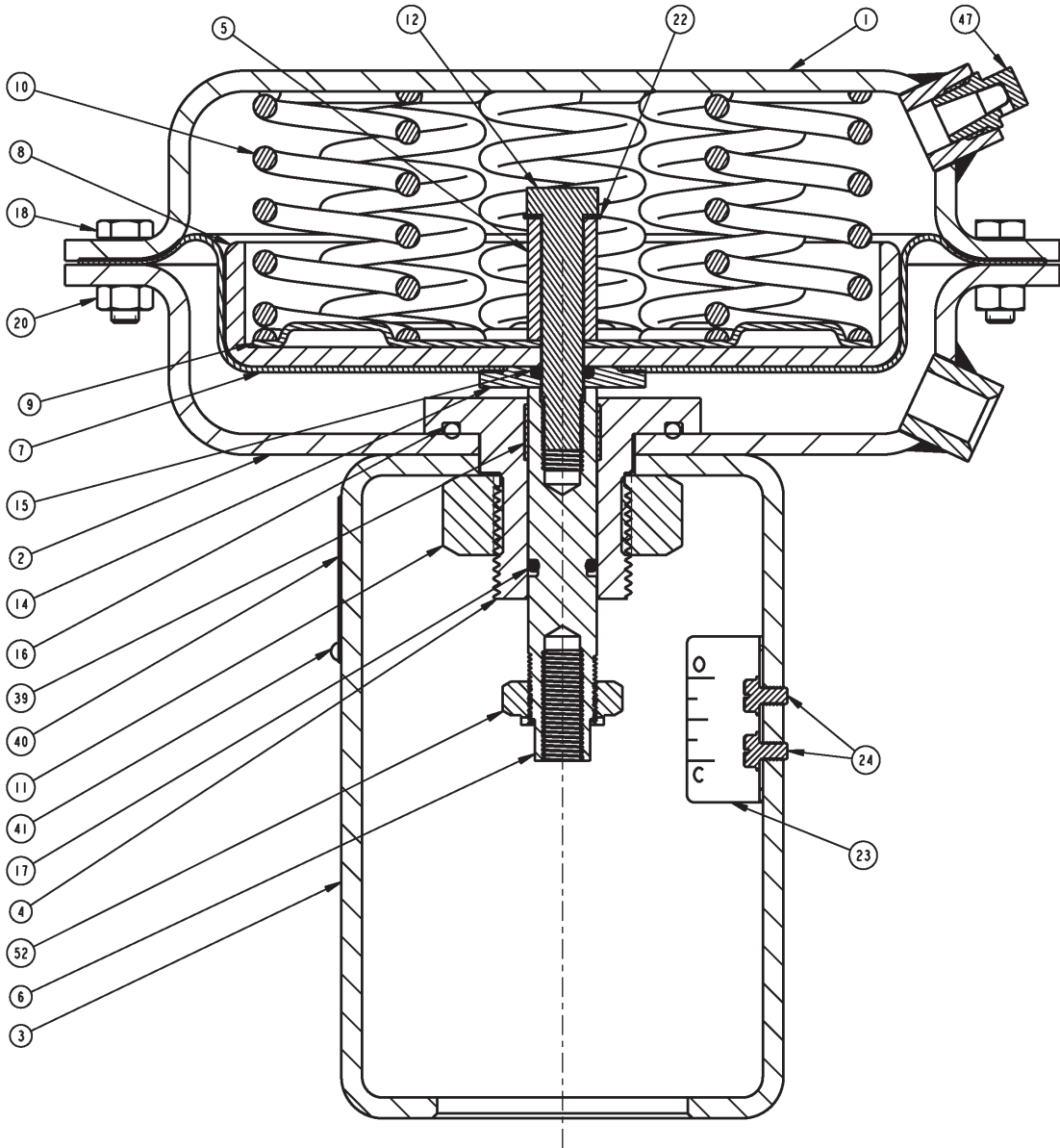

<u>Item No.</u>	<u>Description</u>	<u>Item No.</u>	<u>Description</u>
1	Case - Top	18	Case Bolts - Short
2	Case - Bottom	20	Case Nut - Short
3	Yoke	22	Stem Lock Washer
4	Attachment Hub	23	Indicator Plate
5	Stem Spacer	24	Indicator Plate Screw
6	Stem	39	Stem Teflon Bushing ‡
7	Diaphragm ‡	40	Name Plate
8	Diaphragm Plate	41	Drive Screw
9	Spring Plate	47	Vent Plug
10	Spring	52	Stem Stop Nut
11	Hub Nut	Not Shown	
12	Stem Bolt	19	Case Bolts - Long
14	Diaphragm Washer	21	Case Nuts - Long
15	Diaphragm Washer O-ring ‡	49	Warning Plate
16	Attachment Hub O-ring ‡	‡	Recommended replacement parts.
17	Stem O-ring ‡		

C53 Actuator ATC - FO Action

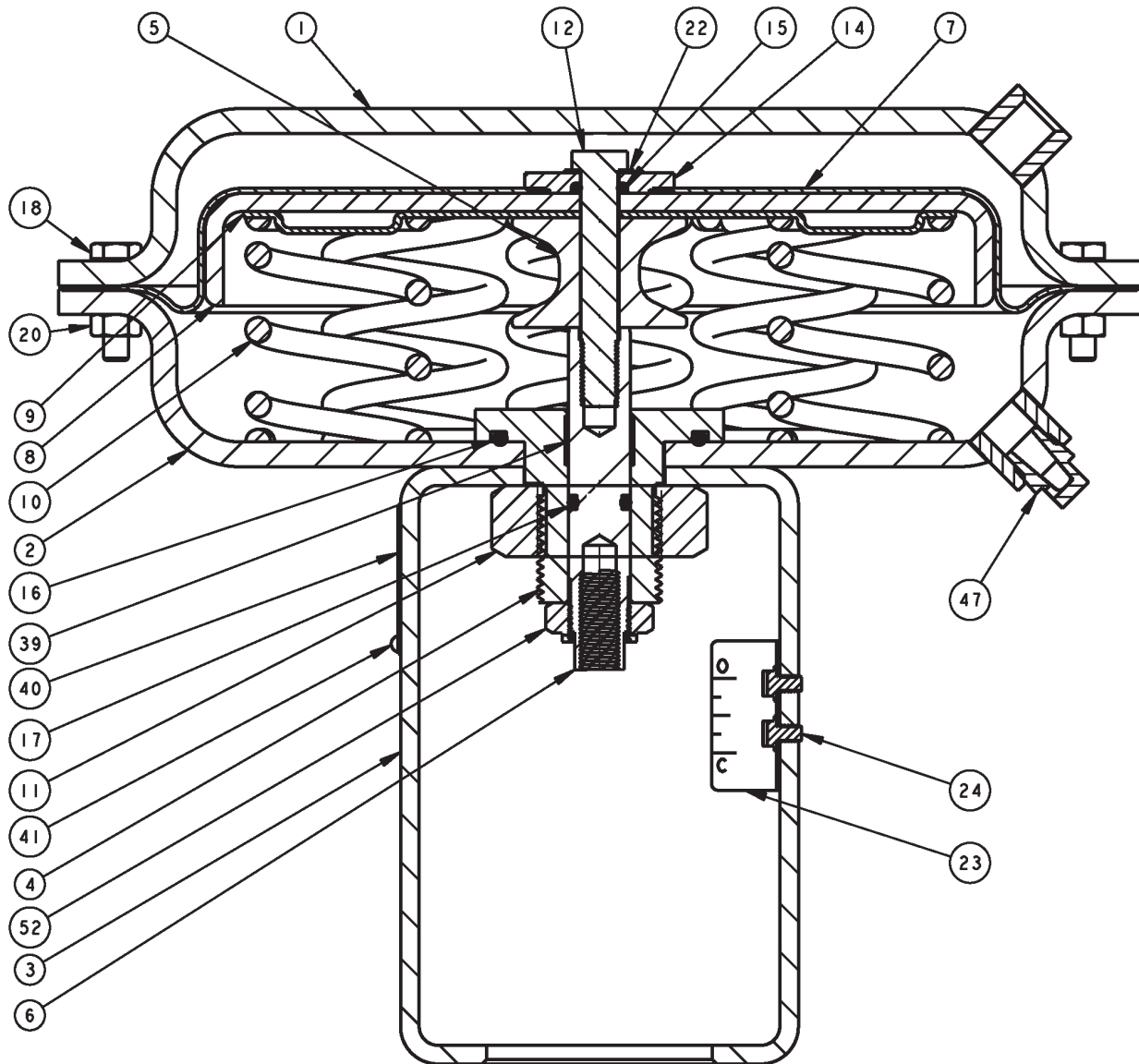

<u>Item No.</u>	<u>Description</u>
1	Case - Top
2	Case - Bottom
3	Yoke
4	Attachment Hub
5	Stem Spacer
6	Stem
7	Diaphragm ‡
8	Diaphragm Plate ‡
9	Spring Plate
10	Spring
11	Hub Nut
12	Stem Bolt
14	Diaphragm Washer
15	Diaphragm Washer O-ring ‡
16	Attachment Hub O-ring ‡
17	Stem O-ring ‡
18	Case Bolts - Short
20	Case Nut - Short
22	Stem Lock Washer
23	Indicator Plate
24	Indicator Plate Screw
39	Stem Teflon Bushing ‡
40	Name Plate
41	Drive Screw
47	Vent Plug
52	Stem Stop Nut
Not shown	
19	Case Bolts - Long
21	Case Nuts - Long
49	Warning Plate
‡	Recommended replacement parts.

C53 Actuator ATO - FC Action

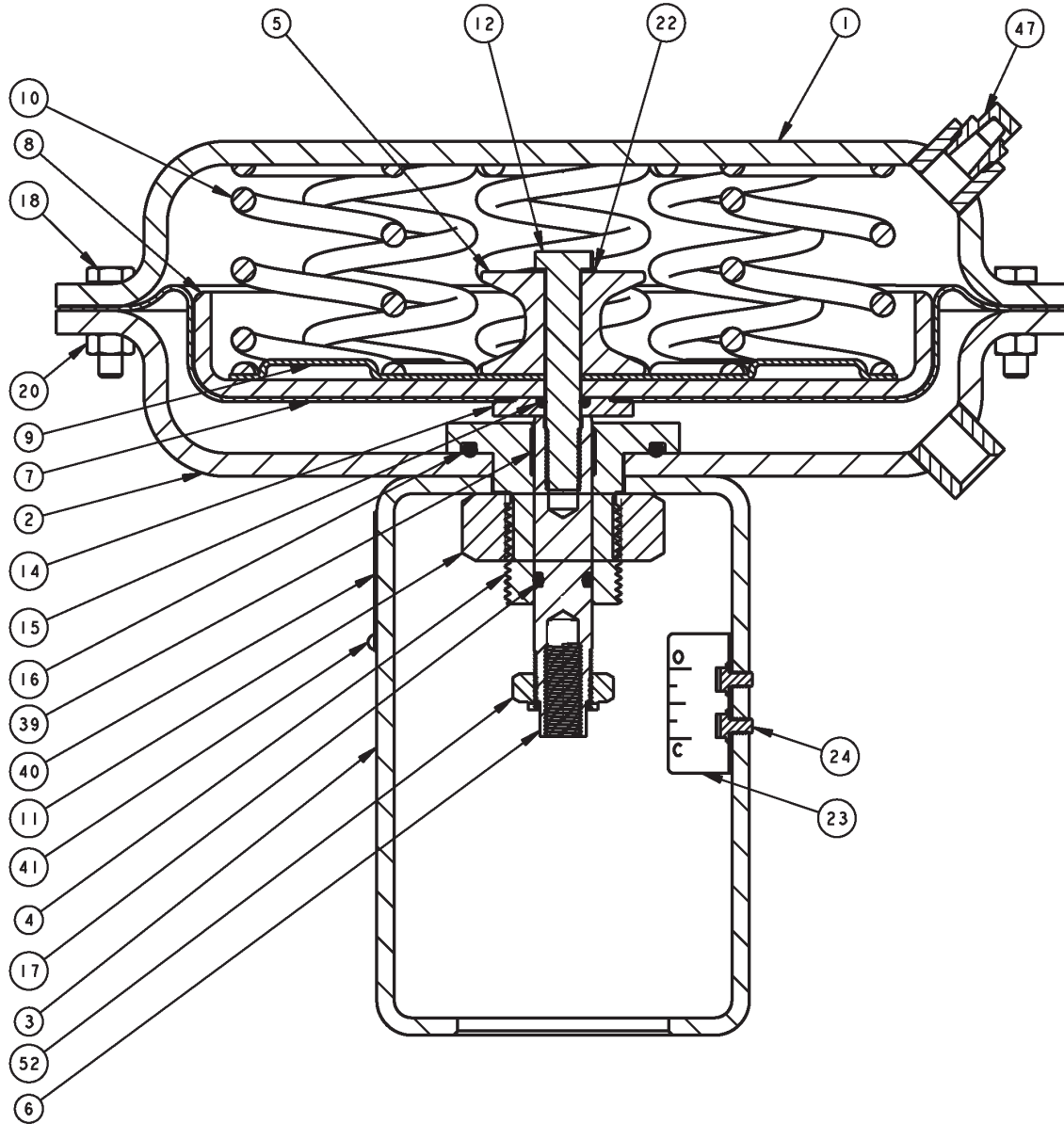

<u>Item No.</u>	<u>Description</u>		<u>Item No.</u>	<u>Description</u>
1	Case - Top		18	Case Bolts - Short
2	Case - Bottom		20	Case Nut - Short
3	Yoke		22	Stem Lock Washer
4	Attachment Hub		23	Indicator Plate
5	Stem Spacer		24	Indicator Plate Screw
6	Stem		39	Stem Teflon Bushing ‡
7	Diaphragm	‡	40	Name Plate
8	Diaphragm Plate		41	Drive Screw
9	Spring Plate		47	Vent Plug
10	Spring		52	Stem Stop Nut
11	Hub Nut		Not shown	
12	Stem Bolt		19	Case Bolts - Long
14	Diaphragm Washer		21	Case Nuts - Long
15	Diaphragm Washer O-ring ‡		49	Warning Plate
16	Attachment Hub O-ring ‡		‡	Recommended replacement parts.
17	Stem O-ring ‡			

Handwheel Assembly

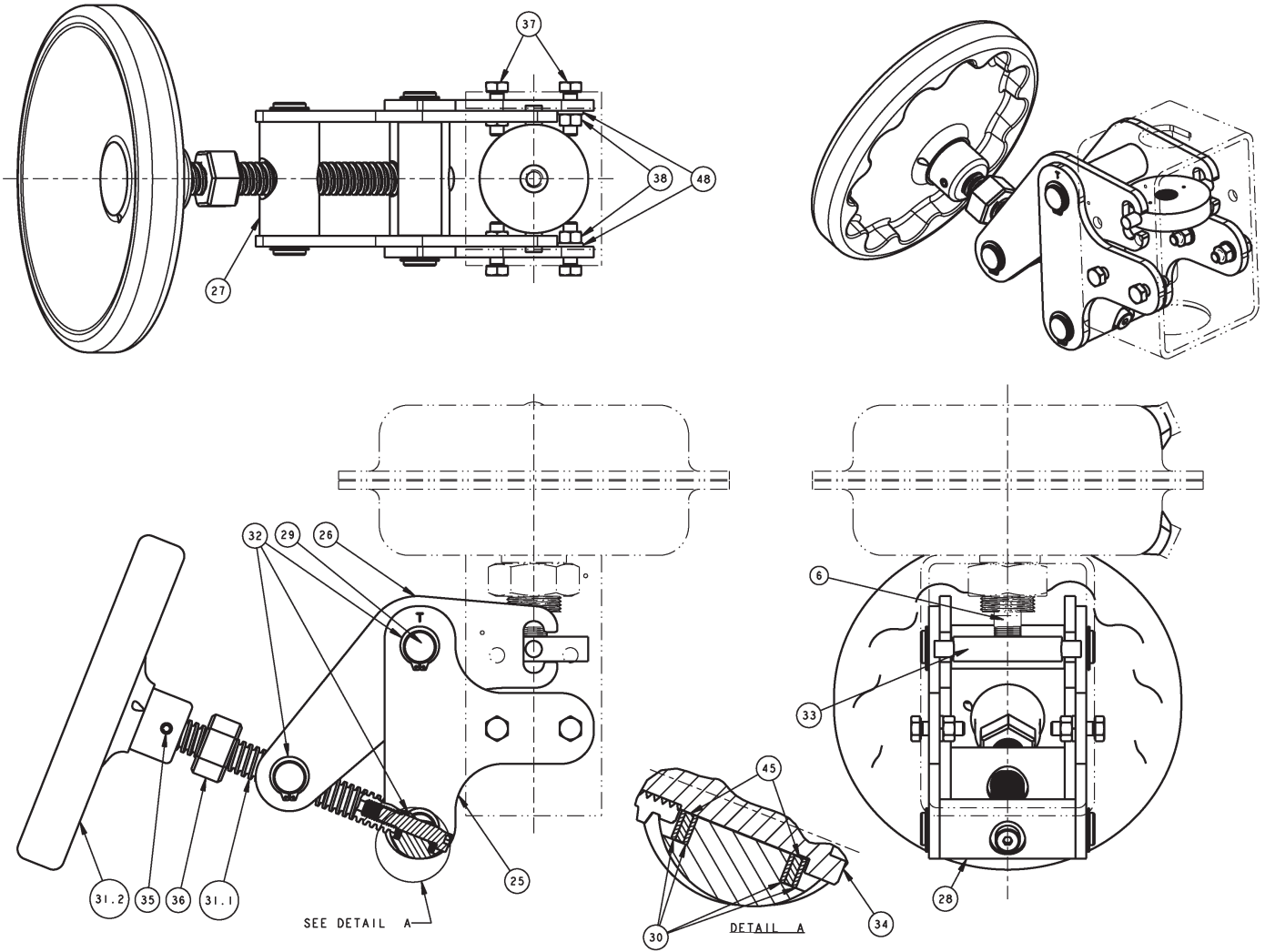

<u>Item No.</u>	<u>Description</u>
25	Fixed Bracket
26	Pivot Bracket
27	Threaded Pin
28	Thrust Pin
29	Rocker Pin
30	Thrust Washer
31	Handwheel Assy
32	Retaining Ring
33	Coupling Assy

<u>Item No.</u>	<u>Description</u>
34	Shoulder Bolt
35	Pin (Spring)
36	Lock Nut
37	Cap Screw
38	Nut
45	Handwheel Washer
48	Lock Washer

NOTES

Cashco, Inc.
P.O. Box 6
Ellsworth, KS 67439-0006
PH (785) 472-4461
Fax. # (785) 472-3539
www.cashco.com
email: sales@cashco.com

Cashco GmbH
Handwerkerstrasse 15
15366 Hoppegarten, Germany
PH +49 3342 30968 0
Fax. No. +49 3342 30968 29
www.cashco.com
email: germany@cashco.com

Cashco do Brasil, Ltda.
Al.Venus, 340
Indaiatuba - Sao Paulo, Brazil
PH +55 11 99677 7177
Fax. No.
www.cashco.com
email: brazil@cashco.com