



## TG-300 Installation and Operation Manual

### High Output Ozone Generator



Ozone Solutions  
451 Black Forest Road  
Hull, IA 51239  
Phone: (712) 439-6889  
Fax: (712) 439-6733

# Table of Contents

Safety Precautions _____	3
Introduction _____	4
Theory of Operation _____	4
Specifications _____	5
Ozone output _____	5
Feed gas requirements _____	5
Cell pressure _____	5
Electrical Input _____	5
TG-300 Component Diagram _____	6
TG-300 Component Description _____	6
Performance Chart _____	8
Setting up the TG-300 _____	9
Installation Guidelines _____	9
Wall Mounting _____	9
Ozone/Oxygen Hookup _____	9
Starting up the TG-300 _____	9
Operation Guidelines _____	10
Indicator Light _____	10
Remote Operation or Control _____	11
Cooling Water _____	12
Optimal Environment _____	13
Maintenance and Service Parts _____	13
Contact Information _____	13
Warranty _____	14

# Safety Precautions

Ozone is a powerful oxidizing agent. Observe strict operating procedures while using ozone equipment. **It is imperative that only ozone compatible materials are used in conjunction with the ozone system.**

Ensure that the Ozone Generator is in a well-ventilated area. Do not allow rain or condensation to contact the Ozone Generator. The Ozone Generator is not weather proof. The unit must be operator indoors or in an enclosure in a non-condensing environment.

**Note:** If the operator has asthma, he or she must not enter an airspace that has a significant ozone concentration. Ozone can induce an asthma attack.

Carefully review and familiarize yourself with the following important safety information concerning the Ozone Generator:

1. Ozone is an extremely aggressive and powerful oxidizer. The Occupational Safety and Health Administration (OSHA) 8-hour exposure limit is 0.10-PPM. The OSHA 15-minute exposure limit for ozone is 0.3 PPM. Above 0.3 PPM, there is the risk of damage to respiratory tissues.
2. People who have no sense of smell should not operate this equipment.
3. Never attempt to verify ozone production by directly breathing or smelling the ozone outlet or the ozone-tubing outlet.
4. The Ozone Generator contains high voltages. Unauthorized entry can result in serious injury or death. For service instructions, contact Ozone Solutions.
5. Make sure all tubing connections between the Ozone Generator and the injection point are secure and in good working condition. Failure to do so could result in the discharge of ozone into an undesired space.

## Introduction

The TG-300 Ozone Generator produces ozone from oxygen via corona discharge. The TG-300 is capable of generating 300 g/hr of ozone with a feed gas of 90% oxygen at 60 LPM, and 140 g/hr of ozone with a feed gas of 90% oxygen at 30 LPM. Ozone has many uses including pathogen inactivation and destruction of odorous gases.

### Ozone Generation from Corona Discharge

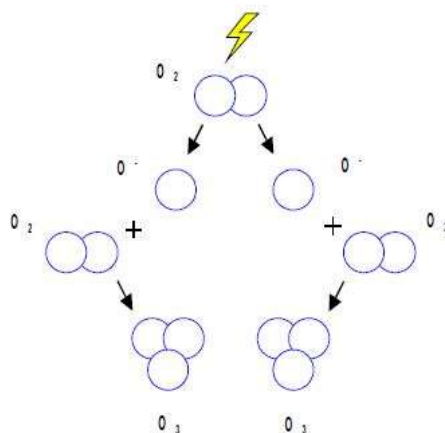

## Theory of Operation

The TG-300 Ozone Generator produces ozone via corona discharge. This process uses an electrical spark to split the molecular bond of natural diatomic oxygen to form the atomic  $O^{\cdot}$  form of oxygen. These  $O^{\cdot}$  atoms then bond to other  $O_2$  molecules to form  $O_3$  (ozone).

The spark inside the TG-300 is a controlled corona. This spark, an intense corona, is produced by forcing a high voltage source through a dielectric and a small air gap. These actions take place in a chamber called the corona cell. The spark occurs at a higher-than-line voltage and much higher-than-line frequencies. These changes in voltage and frequency are accomplished with the circuit board and transformer inside the TG-300. The oxygen feed is forced through the small air gap along the dielectric and intense corona. This process splits the oxygen molecule and generates ozone.

The basic fundamentals of flow and velocity of gas through the corona cell allow for more ozone production (g/hr) as oxygen flow increases. As the flow increases, the concentration of ozone (% by weight) decreases. Conversely, as the flow decreases, the concentration of ozone increases. At very low oxygen flow rates, the oxygen remains in the corona cell for a longer period of time. The contact time allows for higher percentage of oxygen to be converted into ozone. The proper ozone production and

concentration for the necessary application can be determined and achieved using the TG-300 performance charts included in this manual.

While flow and pressure of the oxygen feed gas affect the ozone output the most, the pressure of the feed gas into the corona cell also has an effect on the production of ozone. With higher pressures of oxygen, there is more oxygen in a given space. This increased concentration allows for more molecular  $O_2$  to be present in the corona cell and to be converted into  $O_3$ . The increased concentration also increases the contact time given the gas flow remains constant. The effect on the ozone generation process allows for the production of ozone to increase with higher pressures. Also, with higher pressures, the TG-300 will consume more electrical power as it takes more energy to create a spark in an environment with a high concentration of oxygen. The TG-300 automatically compensates for the varying pressures and maximizes the ozone output for every pressure level. There is a point where pressures will begin to have a negative effect on ozone production. Higher pressures will increase the reaction rate of ozone, causing the decomposition of ozone back into molecular oxygen in less time than at ambient pressures.

The TG-300 is a water-cooled Ozone Generator. The corona cell does create a substantial amount of heat that must be removed. This heat is created by the high voltage and high frequency corona that is contained inside the TG-300. The heat is removed by the vent on the side of the Ozone Generator.

## Specifications

### Ozone output

340 g/hr ozone at 5% and 80 LPM oxygen  
300 g/hr ozone at 5.8% and 60 LPM oxygen  
140 g/hr ozone at 8.2% and 30 LPM oxygen

These are estimates; see your specific performance chart for more information.

### Feed gas requirements

Oxygen must be dried to a minimum of  $-70$  °F dewpoint. No minimum oxygen flow for intermittent, short periods of time. Maximum oxygen flow of 30 L/min (60 SCFH).

### Cell pressure

Pressure on the corona cells must not exceed a maximum of 80 PSI, or go below 0.1 PSI.

### Electrical Input

220 VAC, single phase, 50/60 Hz, 11 Amps



# TG-300 Component Diagram

LEGEND	
1.	Mounting tabs for wall mounting
2.	ON/OFF Switch
3.	Oxygen Pressure Gauge
4.	Ozone ON Light
5.	Ozone Output Control
6.	Oxygen Flow Meter
7.	Oxygen Flow Control
8.	Enclosure latch
9.	Power Cord
10.	Main Disconnect
11.	Ozone Outlet
12.	Oxygen Inlet
13.	Cooling Water Out
14.	Cooling Water IN
15.	Cooling Water Flow Meter
16.	Cooling Water Flow Control



## TG-300 Component Description

- 1. Mounting tabs for wall mounting** – The TG-300 can be mounted to a wall or rack using the stainless steel mounting tabs.
- 2. ON/OFF Switch** – The TG-300 is turned ON and OFF using the main ON/OFF switch on the front panel.
- 3. Oxygen Pressure Gauge** – shows the oxygen pressure on the ozone generator cell.
- 4. Ozone ON Light** – illuminates when ozone is ON and being produced. The ozone generator can be ON and not produce ozone if the ozone output control is turned to 0, this can be indicated by this light.

5. **Ozone Output Control** – will control ozone output from 0-100% electronically by changing the electrical power delivered to the cell.
6. **Oxygen Flow Meter** – measuring and indicates oxygen flow through the ozone generator.
7. **Oxygen Flow Control** – adjusts oxygen flow through the ozone generator.
8. **Enclosure Latch** – will latch and lock door of enclosure, a common flat blade screw-driver can be used to open the enclosure.
9. **Power Cord** – 220V power cord will supply power to the ozone generator.
10. **Main Disconnect** – Unlatches all power.
11. **Ozone Outlet** – 1/2" Stainless Steel Compression ozone outlet fitting.
12. **Oxygen Inlet** – 1/2" Stainless Steel Compression oxygen inlet fitting.
13. **Cooling Water Out** – 1/2" Brass Female NPT for cooling water.
14. **Cooling Water In** – 1/2" Brass Female NPT for cooling water.
15. **Cooling Water Flow Meter** – measures and indicates cooling water flow through the ozone generator cell.
16. **Cooling Water Flow Control** – adjusts cooling water flow through the ozone generator cell.

# Performance Chart

TG-300 Ozone Generator – Water Cooled Ozone Generator

#1

# #	Oxygen Flow in LPM	Ozone Concentration, % by weight	Ozone Production in g/hr	PSI	COMMENTS
1	20.00	8.20	140.71	20	
2	40.00	6.90	236.81	20	
3	60.00	5.80	298.58	20	
4	80.00	5.00	343.20	20	
5	100.00	4.20	360.36	20	

Ozone Concentration

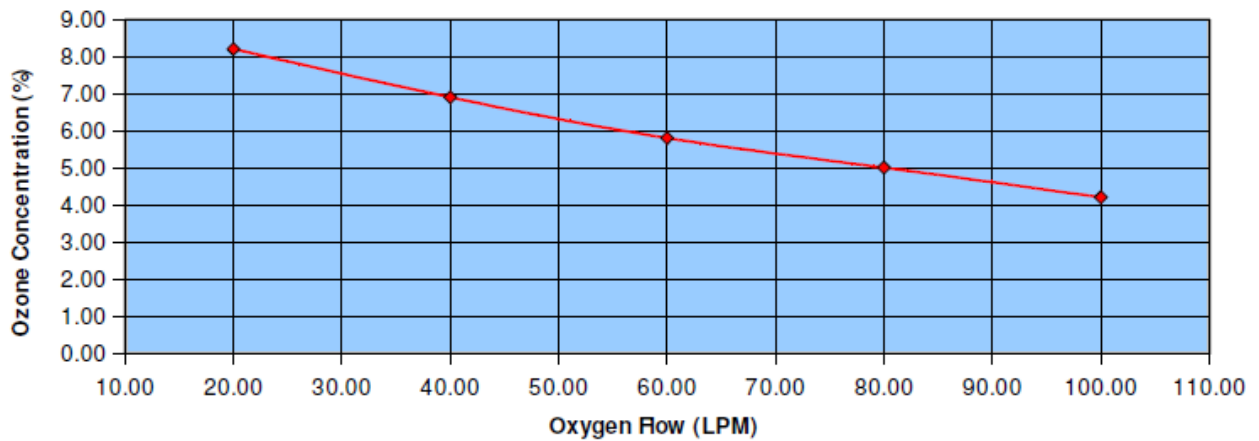

Ozone Production

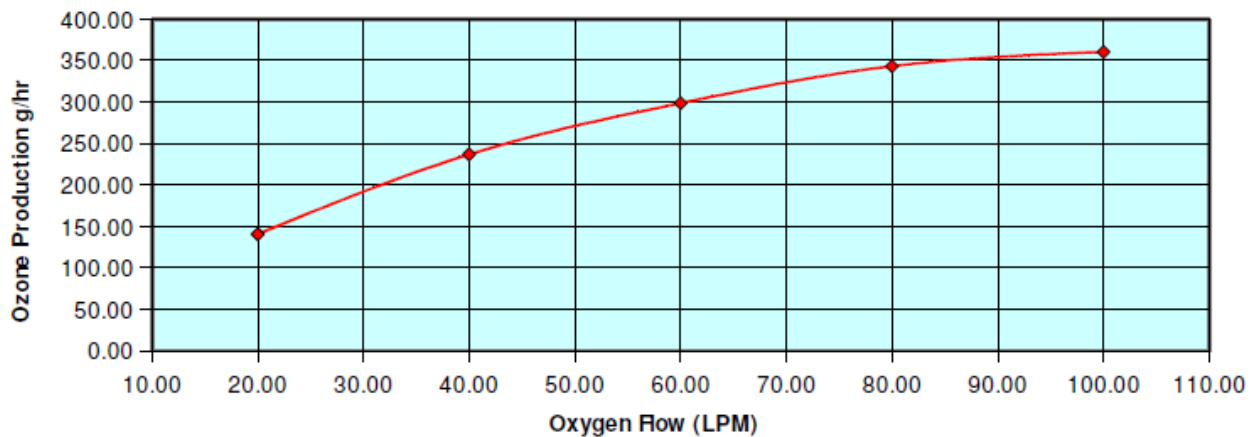

Test was performed at 72°F, Generator was ON for more than 1 hour.

Ozone Analyzer API 460H



# Setting up the TG-300

## Installation Guidelines

- Sufficient access space. There must be at least a foot or two of space around the TG-300 in order to provide room for maintenance service and to allow a free flow of cool air around the unit.
- Adequate power source. Make sure to connect the unit to a grounded power source that is rated for the required electric current and voltage.
- Proper ventilation. The location of the Ozone Generator must be well ventilated with a recommended 6 air changes per hour.

## Wall Mounting

If mounting the TG-300:

1. Use the wall mount tabs on the top of the unit to secure to a wall.
2. Ensure that wall can support the weight of the system.

## Ozone/Oxygen Hookup

1. Using a stainless steel, Teflon, or other high-quality ozone-resistant tubing, connect to the oxygen inlet and ozone outlet fittings on the backside of the TG-300. These connections are 1/2 inch Stainless Steel Compression connections.
2. With an open-ended wrench, tighten the compression-fitting nuts that hold the tubing in place and seal it to the TG-300. See the image below for guidance.  
Note: Keep in mind that the ferrule is not reusable and will be permanently secured to the tubing you have tightened into this fitting.
3. When the oxygen is flowing, spray the fitting with soapy water and watch for air bubbles. If none appear, the seal is secure.

## Starting up the TG-300

Here are tips for ensuring performance for the TG-300:

1. Make sure oxygen is flowing through the unit before beginning the initial start-up process.
2. Set the flow and pressure to that which is expected for future operation.
3. Ensure that there are no leaks at the backside input and output connections by spraying soapy water and watching for air bubbles.
4. Check the downstream systems where the ozone is to be used. Make sure that there are no leaks or other open lines that may cause excess ozone to escape. It is very hazardous to have exposed ozone in areas where personnel are located.



5. Ensure that the oxygen flow is measure and controlled to rates that do not exceed rated capacity of the Ozone Generator.

To start the Ozone Generator, turn the 10-position dial to the 0-position, then switch the main power on. The on light will illuminate indicating the Ozone Generator is powered up and ready for operation. Turn the 10-position dial up slowly. Once the setting is above 2, the green ozone light will turn on. This indicates the unit is producing ozone.

## Operation Guidelines

### Indicator Light

While the Ozone Generator is in operation, the green light will remain lit to indicate that the inverter is on, power is being sent to the transformer, and ozone is being generated. Additionally, fans will run in order to cool the unit throughout the time that it is on.

This light is also responsible for indicating proper operation of the inverter:

- When the green light is on, the inverter is active and operating normally.
- When the green light is off, the inverter is malfunctioning and must be repaired.
- When the green light is flashing, the inverter is off due to a normal condition that could be caused by the potentiometer being adjusted to the lower limits.

Adjust the oxygen feed, gas flow, and pressure to the necessary values for continued ozone production and concentrations to remain without issue and do not exceed capacity of the Ozone Generator. Use the attached Ozone Generator performance charts in order to evaluate the necessary oxygen flow required for proper function.

If installing more than one generator, set all of the flow rates to an identical setting so that each generator has the same flow rate passing through the unit.

## Remote Operation or Control

Refer to the diagram below for details on remote contacts on the TG-300 Ozone Generator.

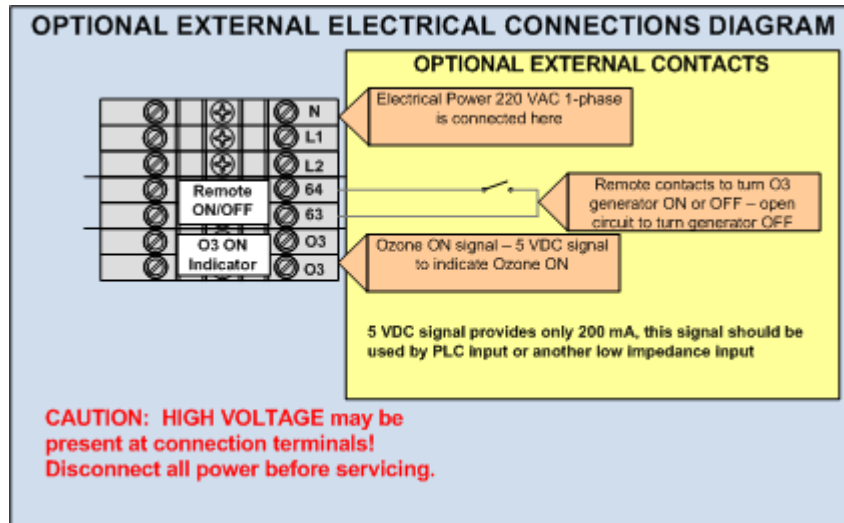

The TG-300 can be turned ON or OFF remotely by removing the jumper in terminals 63 & 64. By placing a remote switch in this circuit the ozone generator inverter will turn ON and OFF to start and stop ozone production from a remote location or an automation system.

When the Inverter is ON and producing ozone there is a 5 VDC reference signal that can be wired to remote location. This can be wired in the O3 terminals. This wiring is in series with the green light on the front panel of the TG-300.

There, also the output of the unit can be adjusted from 0-100% via a 0-10 volt or 4-20 mA input.

**Note:** The use and type of the remote control must be qualified prior to implementation, so please contact Ozone Solutions for more information before installing a remote for your unit.

Maximum ozone production is realized at 10-20 PSI of pressure. Pressures up to 100 PSI are sufficient but will not produce the maximum ozone production. If pressures will reach higher than 30 PSI, the generator must be tuned properly to maximize the efficiency of the machine. Please contact Ozone Solutions for information regarding this process.

The Ozone Generator will not operate under a vacuum and must have at least 1 PSI of pressure for ozone production. Below 1 PSI the cell will shut down and produce no ozone.

**IMPORTANT:** When setting the flow and pressure of the Ozone Generator it is important to know that pressure will have a factor on the flow displayed on most flow meters. If the actual discharge pressure is substantially above atmospheric pressure, the reading can be adjusted to determine the precise flow rate, according to the following formula (using PSIG):

$$(adjusted\ flow) = (measured\ flow) \times \sqrt{\frac{oxygen\ -\ pressure + 14.7}{14.7}}$$

Please contact Ozone Solutions if additional assistance is required.

Do **not** allow the oxygen or ozone to vent freely.

Do **not** exceed rated capacity.

The ozone output can be adjusted using 10-position dial installed on the unit. The dial on the potentiometer can adjust the ozone from 0-100%. This reading is not perfectly linear; the actual output should be measured with an ozone analyzer. The dial adjusts the voltage to the cell from 1-100%. At the lower limits when ozone is not being produced, the inverter will turn off. When the inverter is off without a current, the green light will flash.

The TG-300 Ozone Generator has a flow meter and a pressure gauge installed, they may be used to evaluate the flow and pressure on the corona cell. The pressure gauge on the unit can be used to calculate the actual adjusted flow of the TG-300. The pressure gauge and flow meter have been installed before the corona cell and may not be 100% ozone resistant. It is important not to allow ozone to flow in the reverse direction when the oxygen flow is turned off. After running the Ozone Generator, a check of the valves is strongly recommended to prevent back flow

Ensure that the Oxygen Generator is in a well-ventilated area. If the space is occupied, sufficient ventilation must be provided to prevent the accumulation of low oxygen concentration waste gas in the space.

## Cooling Water

Cooling Water is necessary through the TG-300 Ozone Generator to remove heat from the Ozone Generator cell. Cooling water supplied should be 70° F or cooler. Cooling water flow must be 1-2 gallons per minute with at least 9,000 BTU. Water connections on the TG-300 are ½ inch Brass Female NPT and are located on the side of the unit.

To ensure proper cooling, disconnect all power sources and open the door to access the cells. The Ozone Generator cells must be cool to the touch. This will verify that the cooling water flow is sufficient for proper cooling and ozone generation.



## Optimal Environment

The Ozone Generator is not weather proof; therefore, it must be operated indoors in a non-condensing, dust-free environment. Sufficient ventilation must be provided to prevent the accumulation of ozone in the event of a leak. Approximately three air changes per hour are recommended.

The operating temperature should be 40°F to 95°F, and the storage temperature should be -20°F to 170°F. No dust or debris may be in the area; it must be clean and dry environment.

## Maintenance and Service Parts

As long as the feed gas is kept dry, dust free, and pure, the Ozone Generator will not need maintenance. Ensure strict maintenance procedures of the oxygen generator as specified in the oxygen generator manual.

There are no serviceable parts inside the TG-300. If any part fails to operate or other problems arise call Ozone Solutions for service and repair.

The mechanical specifications are as follows:

Dimensions: 36-in height x 30-in width x 20-in depth  
(91.4-cm height x 76.2-cm width x 50.8-cm depth)  
Weight: 180 lbs  
(81.65 kg)

## Contact Information

Ozone Solutions, Inc.  
451 Black Forest Road  
Hull, IA 51239 USA

Phone: (712) 439-6880  
Fax: (712) 439-6733  
Email: [sales@ozonesolutions.com](mailto:sales@ozonesolutions.com)  
Website: [www.ozonesolutions.com](http://www.ozonesolutions.com)



# Warranty

Ozone Solutions warrants all equipment assembled, manufactured, and sold to be free from defects in material and workmanship under normal use and service for a period of one (1) year after date of sale to the original purchaser.

Some products may have a specific warranty period other than what is outlined in this document. For such products, the manufacturer warranty will supersede this warranty. Ozone Solutions will honor the manufacturer's warranty, but if and when advised by the manufacturer, may have the customer deal directly with the manufacture.

This warranty covers all parts that are not outlined in a product maintenance schedule. This warranty will be void if any piece of the equipment is used in a manner other than what is explicitly outlined in the product manuals.

If any part of the equipment manufactured by Ozone Solutions proves to be defective during the warranty period, please contact Ozone Solutions at 1-888-892-0303, or [tech@ozonesolutions.com](mailto:tech@ozonesolutions.com). Prior authorization is required before working on or shipping a product back to us. Failure to get prior authorization may result in denial of your claim. Once authorized, you may return the defective equipment to Ozone Solutions with the transportation charges prepaid. If Ozone Solutions finds the equipment to be defective, it will be repaired or replaced at our discretion, free of charge, to the original purchaser (F.O.B. factory). This warranty shall not place any liability on Ozone Solutions for any transportation charges, labor, or cost for, or during the replacement of any parts. The replaced part(s) or product will then continue the original warranty duration. The replaced parts will not start a new one (1) year coverage period.

The purchaser by acceptance of the equipment will assume all liability for the consequences of its use or misuse by the purchaser, employees, or others. This warranty shall not apply to any piece of equipment, or part thereof sold by this company which has been subject to any accident caused in transit, alterations by unauthorized service, negligence, abuse, or damage by flood, fire, or act of God.

This warranty shall constitute the entire warranty and/or agreement between Ozone Solutions and the original purchaser, and in lieu of all other warranties, expressed or implied, either oral or written, including the warranty of merchantability and fitness for a particular use and of all other obligations or liabilities on our part. Ozone Solutions neither assumes nor authorizes any other person or entity to assume for us any liability associated with the sale of its products or equipment.

The term "original purchaser," as used in this warranty, means whom the product was originally sold to by Ozone Solutions or by an authorized dealer.

Ozone Solutions reserves the right to make changes in its products without notice. Because of this, Ozone Solutions is not obligated to replace warranty defective part(s) and/or product with the same original part or product.

