



2/2-way valve with isolating diaphragm for medium up to +100°C

- Normally closed or open
- Body material: Brass, Stainless steel
- Double spindle seal
- Compact design

Type 0263 can be combined with...



Type 6012/6014P

Pilot valve

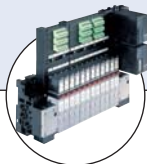

Type 8640/8644

Valve Block



Type 8645

Valve Block



Type 8311

Pressure Sensor/Switch

The externally controlled valve is pneumatically operated. It consists of a diaphragm actuator and a 2-way valve body. Between the valve housing and the drive, there is a hermetically sealed membrane.

The diaphragm actuator moves a spindle with valve disc against a spring and switches the valve. The spindle is designed glandless with double seal. The actuator body is made out of epoxy resin.

Circuit function A

2/2-way valve, externally controlled, normally closed by spring operation with pilot valve

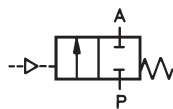

Circuit Function B

2/2-way valve, externally controlled, normally opened by spring, operation with pilot valve

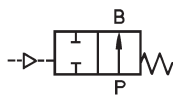

Technical data

Body material	Brass, stainless steel
Inner part valve	Stainless steel
Actuator	Epoxy resin
Seal material	NBR, FKM, EPDM,
Medium	
NBR	neutral medium (e.g. compressed air, town gas, water, hydraulic oil)
FKM	per-solution, oxygen, hot air
EPDM	oil and fat-free medium e.g. hot water, alkaline washing and bleaching lyes
Viscosity	max. 100 mm ² /s
Medium temperature	
NBR	-10 up to +90 °C
FKM	-10 up to +100 °C
EPDM	-10 up to +100 °C
Control medium	neutral gases and liquids, in particular air, water, hydraulic liquids up to max. +90 °C
Pilot pressure	see diagram
Ambient temperature	-10 up to +90 °C
Installation	As required, preferably with actuator upright
Flow rate	measured at +20°C, 1 bar pressure at valve inlet and free outlet
Kv value water [m ³ /h]:	
Pressure values [bar]	Measured as overpressure to the atmospheric pressure

Technical data *continued*

Orifice [mm]	Kv value water [m³/h]	Port connection	Pressure range of circuit function			Weight [kg]
			A normal spring [bar]	A reinforced spring [bar]	B and I normal spring [bar]	
10	1.0	G 3/8	0 - 2.5	0 - 5	0 - 10	0.5
12	2.1	G 1/2	0 - 2	0 - 4.5	0 - 10	0.6

Operating pressure chart - pilot pressure

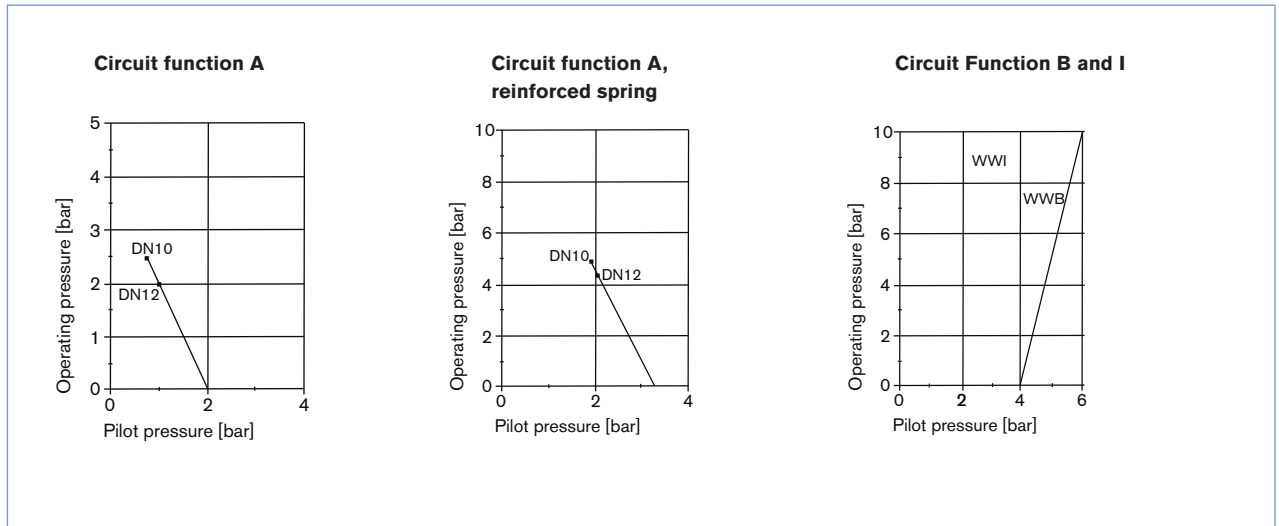

Material

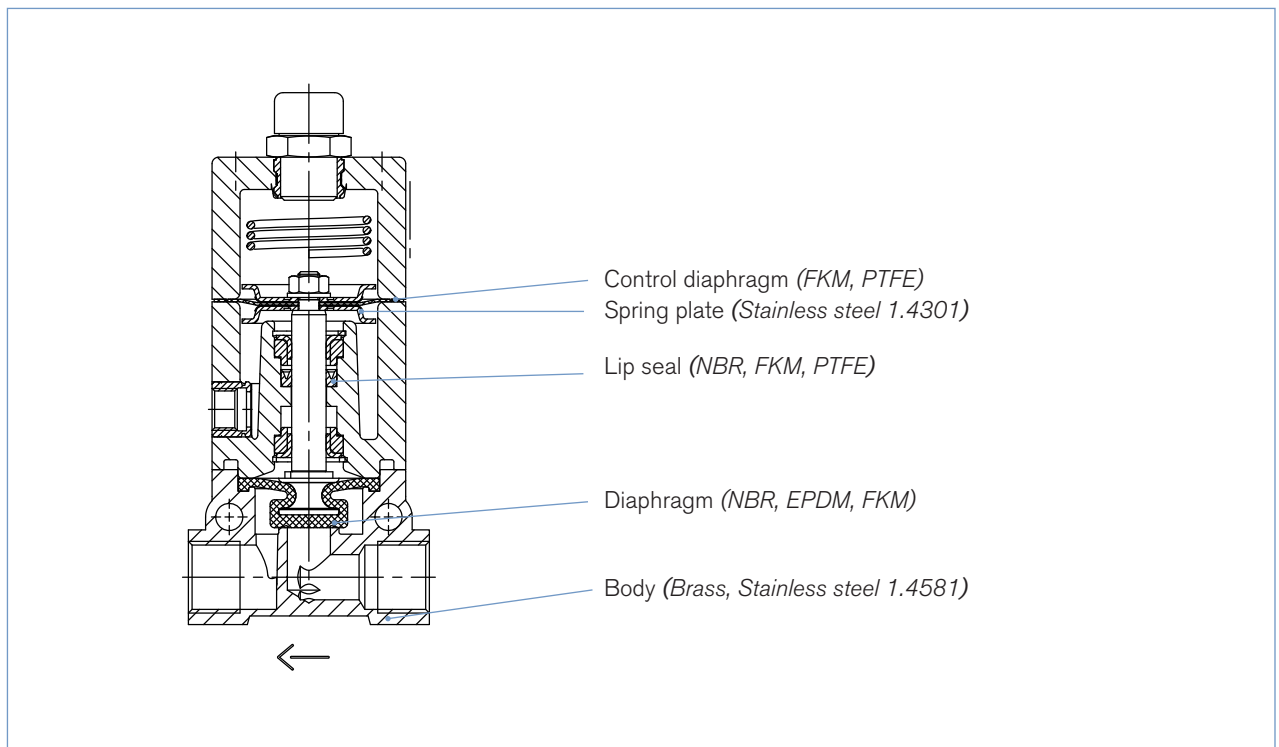

Ordering chart for valves (other versions on request)

Valves with threaded port connection

Circuit function	Orifice [mm]	Port connection	Kv value water [m ³ /h]	Spring	Pressure range [bar]	Seal material	Item no.
Brass body							
A	10	G 3/8	1.0	normal	0-2.5	FKM	027 963
						NBR	027 342
				reinforced	0-5	EPDM	027 929
						FKM	026 903
	12	G 1/2	2.1	normal	0-2	NBR	026 065
						EPDM	026 094
				reinforced	0-4.5	FKM	026 246
						NBR	026 207
B	10	G 3/8	1.0	normal	0-10	EPDM	028 023
						FKM	027 695
				reinforced	0-4.5	NBR	027 881
						EPDM	028 980
	12	G 1/2	2.1	normal	0-10	FKM	028 037
						NBR	026 455
				reinforced	0-4.5	EPDM	027 987
						FKM	028 827
						NBR	027 962
Stainless steel body							
A	12	G 1/2	2.1	reinforced	0-4.5	EPDM	027 428
						FKM	026 944
						NBR	027 328

Dimensions [mm]

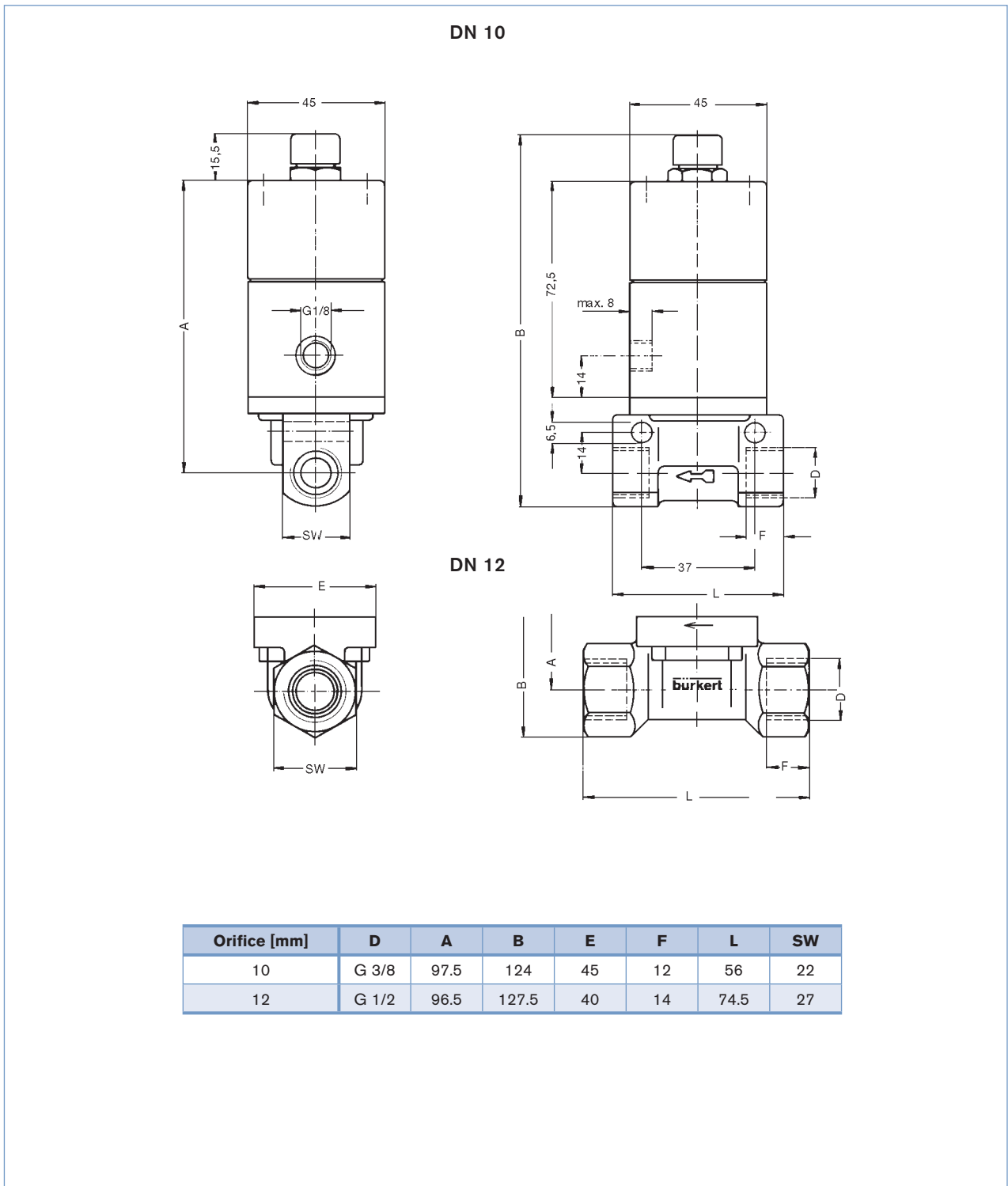

To find your nearest Bürkert facility, click on the orange box →

www.burkert.com