



2/2-way Diaphragm Valve with plastic body, pneumatically operated, DN 12 and 15

- Can be used for aggressive medium
- Body versions: threaded port and true union connection
- Compact design

Type 3230 can be combined with...



Type 6012/6014 P

Pilot valve

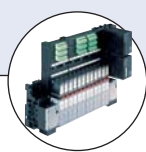

Type 8640/8644

Valve block

2/2-way plastic diaphragm valve, pilot operated with pneumatic actuator and spring return. Used for polluted medium in process and water technology.

Special features (as standard)

- Stroke limitation
- Optical position indicator
- Polluted medium

Technical data	
Orifice	DN 12 and 15
Body material	PVC-U, PP
Seal material	EPDM
Actuator material	PP, glass-fibre reinforced
Medium	Neutral or aggressive medium that do not attack the body and seal materials
Medium temperature	See chart next page
Ambient temperature	0 to +60 °C
Control medium	Lubricated/unlubricated compressed air and other neutral medium (e.g., water)
Pilot pressure	Max. 7 bar, please see chart next page
Port connections	True union Ø16, threaded port G 3/8 True union Ø20 radially expandable
Installation	As required, preferably with actuator in upright position

Ordering chart for valves (other versions on request)

All valves with EPDM diaphragm

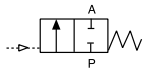
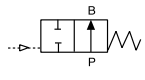
Control function	Orifice [mm]	Kv value water [m ³ /h]	Pressure range +20°C [bar]	Body material	Port connections	Item no.	
A 2/2-way valve NC 	12	2.8	0 - 6	PVC-U	True union Ø 16	784 822	
					G 3/8	784 824	
					PP	True union Ø 16	784 828
						G 3/8	784 830
B 2/2-way valve NO 	12	2.8	0 - 6	PVC-U	True union Ø 16	784 823	
					G 3/8	784 825	
					PP	True union Ø 16	784 829
						G 3/8	784 831
		15	3.5	0 - 6	PVC-U	True union Ø 20	784 827
					PP	True union Ø 20	784 833

The permissible nominal pressure decreases with increasing medium temperature (please see Pressure-temperature chart below).

Pressure-temperature chart

depending on the body materials

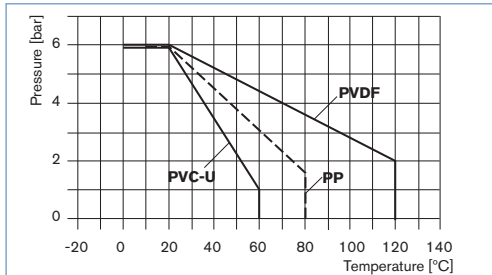

Pilot-pressure chart

NC = Control function A NO = Control function B DA = Control function I

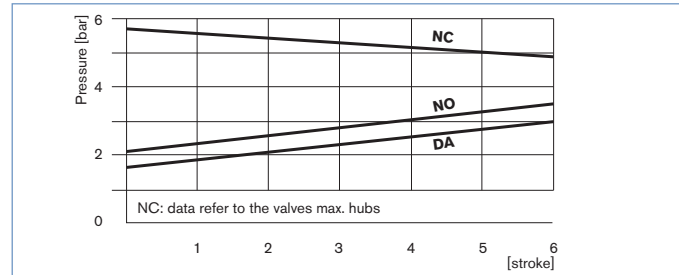

Ordering chart for accessories

3/2-way pilot valves with banjo bolts

Seal material valve FKM, seal material banjo bolt NBR

Type	Pressure inlet P (valve body)	Service port A (banjo bolt)	Orifice [mm]	Q _N value air [l/min]	Pressure range [bar]	Electrical coil connection Ind. Std.	Power consumption [W]	Item no. voltage/frequency [V/Hz]	
								024/DC	230/50
6012P	Tube fitting ø6 mm	G 1/4	1.2	48	0-10	Form B	4	552 283	552 286

Cable plug for Type 2507, Form B

	Item no.
Type 2507, Form B Industrial standard, 0 to 250 V without circuitry (Type 6012 P)	423 845

Dimensions [mm]

True union Ø 20

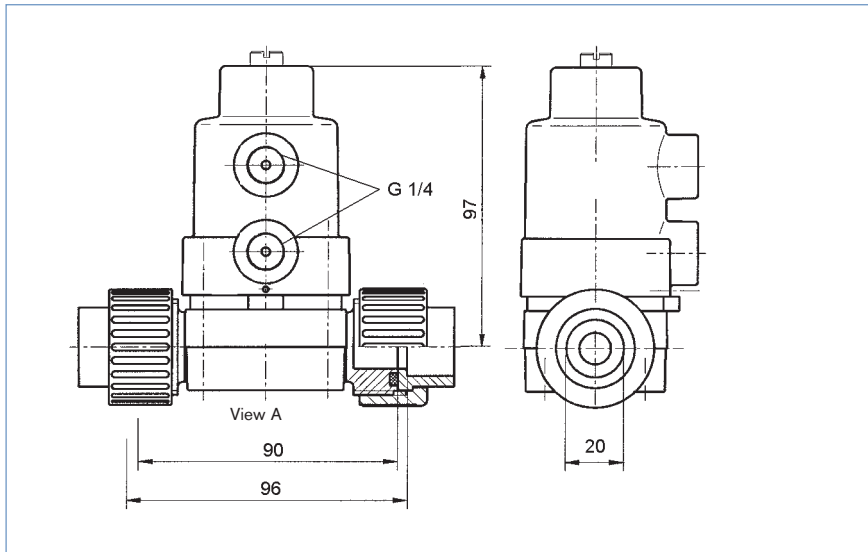

Threaded G 3/8, true union Ø 16

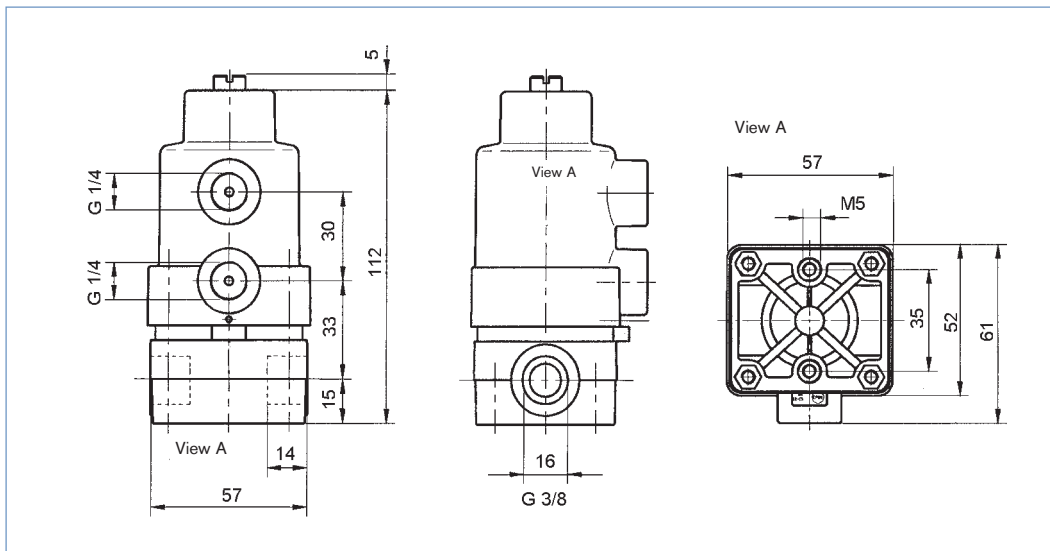

DTS 1000020595 EN Version: C Status: RL (released | freigegeben | valide) printed: 09.05.2016

To find your nearest Bürkert facility, click on the orange box →

www.burkert.com

In case of special application conditions, please consult for advice. Subject to alteration. © Christian Bürkert GmbH & Co. KG 1603/3_EU-en_00891918