

SPECS: OG-750

OXYGEN OUTPUT.....750 scf*/hr @ 45 psig
 19.70 Nm³**/hr @ 310 kPa
 DEWPOINT.....-100°F (-73°C)
 OXYGEN PURITY.....93% ± 3%
 AIR FLOW REQ.....133.0 scf*/min. (avg. flow) @ 90 psig
 3.50 Nm³**/min (avg. flow) @ 621 kPa
 AIR QUALITY REQ.....ISO 8573.1 CLASS 1.4.1 MINIMUM (see below)
 SOUND LEVELS.....70dba @ 1 meter
 DIMENSIONS.....55" x 48" x 88" (WxDxH)
 140cm x 122cm x 224cm
 WEIGHT.....4000 lbs. (1814 Kg.)
 POWER.....120 VAC, 60 Hz, 50 Watts (STD.) or
 220 VAC, 50 Hz, 50 Watts (OPTIONAL)
 AIR INLET.....1" JIC MNPT BULKHEAD
 OXYGEN OUTLET.....1/2" FNPT BULKHEAD
 (WITH 1/2" NPT OXYGEN COUPLING)

RECOMMENDED MINIMUM AIR STORAGE TANK (AST)
 SIZE...200 GALLONS
 RECOMMENDED MINIMUM OXYGEN STORAGE TANK (OST)
 SIZE...200 GALLONS

SPECS: ISO 8573.1 CLASS 1.4.1
 DIRT PARTICLES 1-5 MICRON.....0
 WATER PRESSURE DEWPOINT.....+37°F (940)
 (ppm. vol.) AT 100 psig
 OIL ppm (including vapor).....0.01

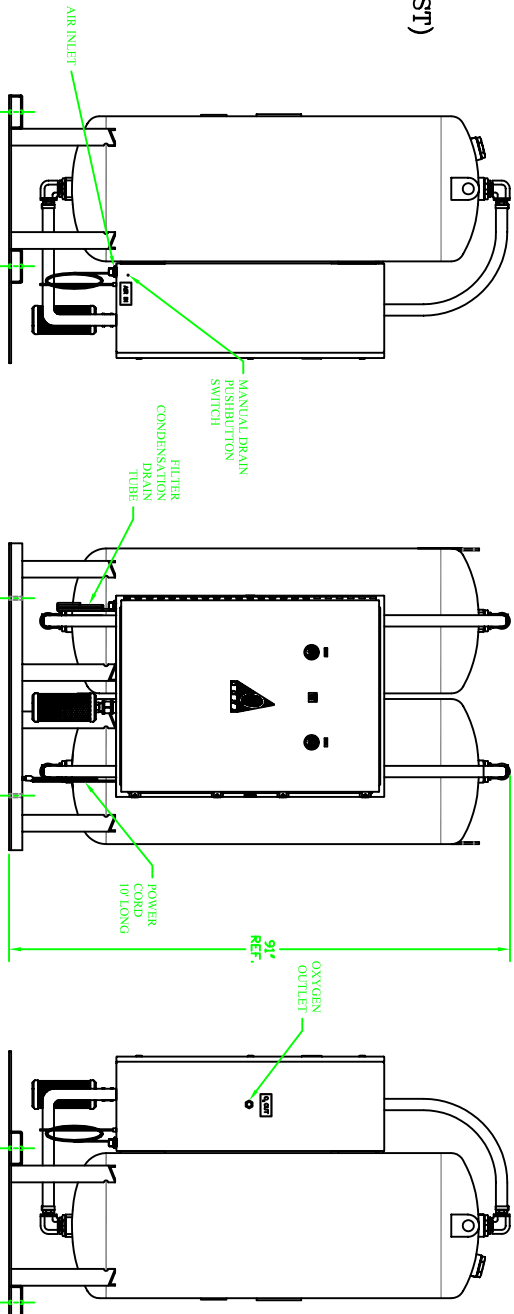
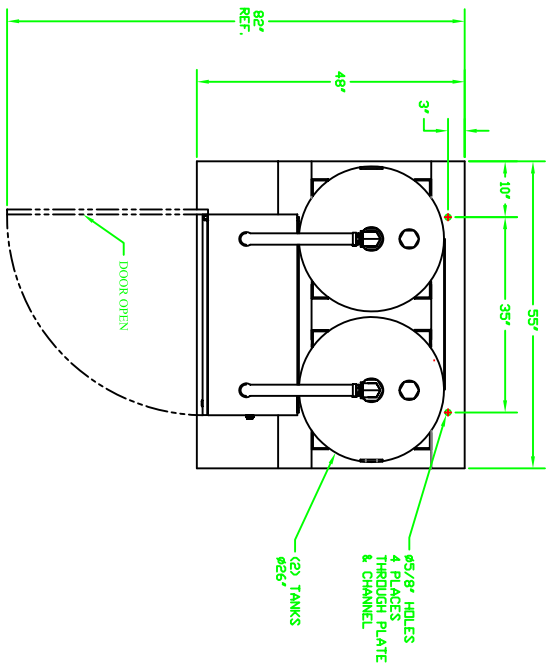

*A Standard Cubic Foot (SCF) is a cubic foot of gas at 14.7 psia (sea level atmospheric pressure) and 60 degrees Fahrenheit
 **A Normal Cubic Meter (Nm³) is a cubic meter of gas at 760mm Hg (sea level atmospheric pressure) and 0 degrees Celsius

REV	DESCRIPTION	DATE	CHK	EDN #
A	CHANGED AIR QUALITY REQUIRED SPEC	10/25/05	JCP	05-10-035

OGSI
 814 Murkisser Drive
 N. Tonawanda, NY 14120
 Phone: (716) 664-5165
 Fax: (716) 664-5173

FILE NAME
 DG-750
 GEN ARR
 REV A

PLOT SCALE
 NTS
 ENGINEER
 J. M. McMAHON

EFFECTIVITY OR SERIAL NO.
 DATE
 10/30/03

DRAWN BY
 J.C. PALDINE
 PAGE
 1 OF 1

TITLE
 GENERAL ARRANGEMENT
 DG-750