

**HIGHER COMPRESSED AIR QUALITY**  
**GREATER RELIABILITY**  
**LONGER LIFETIME**

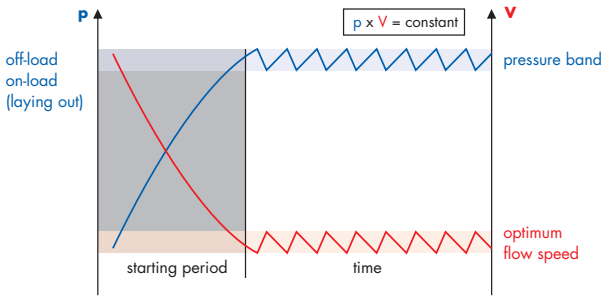

Compressed air treatment systems are always designed for specific flow rates. They can only function at their best within a certain range.



If the compressor startup takes place without any pressure, there is a danger that oil and water droplets will overrun the filter/dryer barrier. This "overrunning" of compressed air treatment systems can create serious problems.

**Oil in the network**

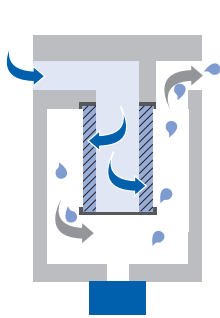

**Coalescence filter:**  
separated droplets are entrained

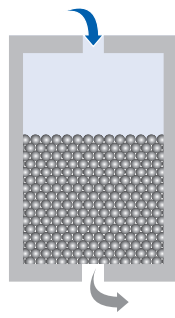

**Activated carbon adsorber:**  
contact time for oil vapour adsorption too short

**Water in the network**

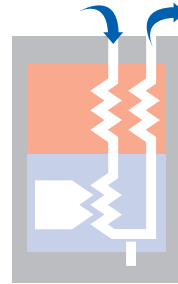

**Refrigeration dryer:**  
contact time in heat exchanger too short

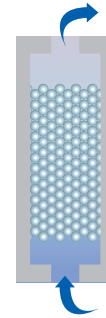

**Membrane dryer:**  
insufficient expansion gradient

**Water separator and filter:**  
Condensate in the quiet zone is entrained

**Adsorption dryer:**  
contact time in desiccant bed too short

**The solution:**

**MINIMUM PRESSURE VALVES**



**Operational reliability**

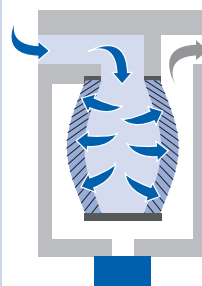

**Filter:**  
Tensile stress on the drainage layer can lead to tearing or complete loss of drainage function

**Adsorption dryer:**  
increased abrasion/loss of desiccant reduces dryer efficiency. Higher cost due to dust filter clogging up quickly.

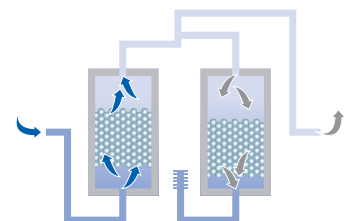

# HIGHER COMPRESSED AIR QUALITY

## GREATER RELIABILITY

## LONGER LIFETIME

### TECHNICAL DATA

Filter	Max. flow rate m <sup>3</sup> /h	Weight
MPVL15B	78	0.35
MPVL20B	102	0.45
MPVL25B	240	0.8
MPVL40B	414	1.5
MPVL50B	690	3.3
MPVL50F	690	5.7
MPVL65F	1080	9.5
MPVL80F	1620	13

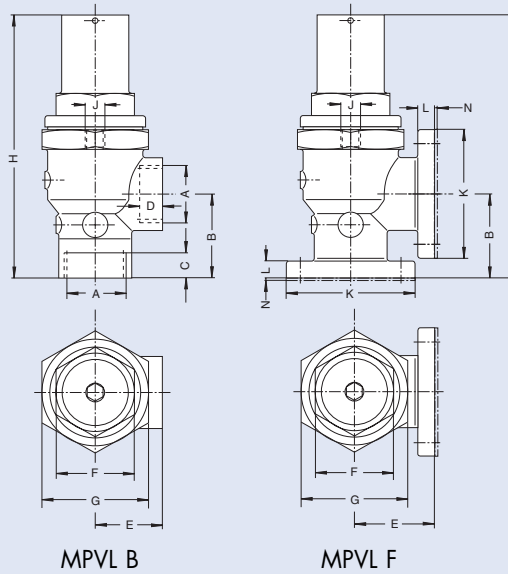

max. operating pressure	16 bar
operating temperature	0 to 100 °C
max. flow resistance	0.03 – 0.2 bar
start of opening	4.75 bar +/-0.25 bar
valve fully open	1.5 to 2 bar above opening pressure
valve fully closed	0.5 to 1 bar below opening pressure
flow rate related to	20 °C and 1 bar

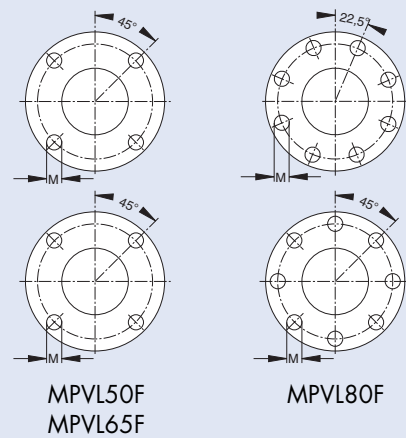

### DIMENSIONS

Filter	A	B	C	D	E	F	G	H	J	K	L	M	N*
MPVL15B	G 1/2	43	13	13	31	36	46	110					
MPVL20B	G 3/4	50.5	15	15	36	46	55	124	M5				
MPVL25B	G 1	56.5	15	15	42,5	55	65	138	M5				
MPVL32B	G 1 1/4	67.5	20	20	48	50	70	175	M8				
MPVL40B	G 1 1/2	67.5	20	20	55	65	85	214	M8				
MPVL50B	G 2	78	24	24	66	85	100	240	M10				
MPVL50F	DN 50	100			120	85	100	262	M10	165	22	4x Ø18 TK Ø125	
MPVL65F	DN 65	103			150	95	130	321	M10	185	24	4x Ø18 TK Ø145	
MPVL80F	DN 80	125			125	115	145	389	M12	190,5	24	4x Ø18 TK Ø160	2

Valve type supplied with BEKO flange seals for installation between plain flanges.

Subject to technical changes without prior notice; the information and data do not represent product characteristics within the meaning of the German Civil Code (BGB)

© Registered trademarks of BEKO TECHNOLOGIES GmbH, Neuss



**BEKO TECHNOLOGIES GMBH**

Im Taubental 7  
41468 Neuss  
Germany

Phone +49 2131 988-0  
Fax +49 2131 988-900  
beko@beko.de

[www.beko.de](http://www.beko.de)