

LANCER®

ICD 2400 Free Standing Dispenser



The ICD 2400 is designed using the highest quality materials and state-of-the-art technology providing our customers with consistent drink quality.

- Available with six or eight valves
- Stainless steel construction with sealed-in cold plate
- 3/4" drain with strainer to prevent ice blockage
- Stainless steel flooded soda manifold and multiple plain water configuration
- Ice bin insulated with CFC free structural foam
- Tower designed with removable splash plate and drip tray for easy cleaning
- Dispenser can accommodate any number of non-carbonated drinks
- Optional top merchandiser and back marquee feature lighted graphics for maximum impact
- Cabinet supplied with 6" leg kit or optional casters
- Splash guards optional



ETL CERTIFIED TO UL STD 471 AND
CAN/CSA STD 22.2 NO. 120

LANCER®

ICD 2400 Free Standing

OPTIONS

Marquee



Merchandiser



Splash Guards



Casters

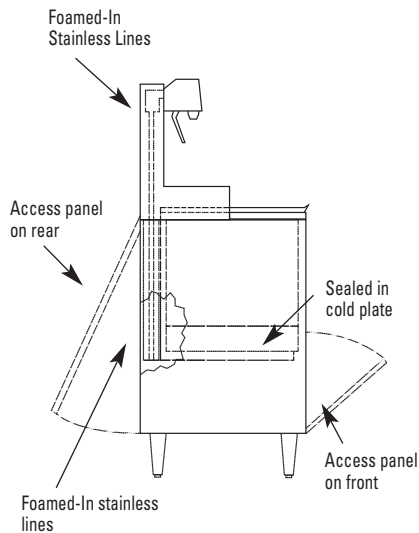

SPECIFICATIONS

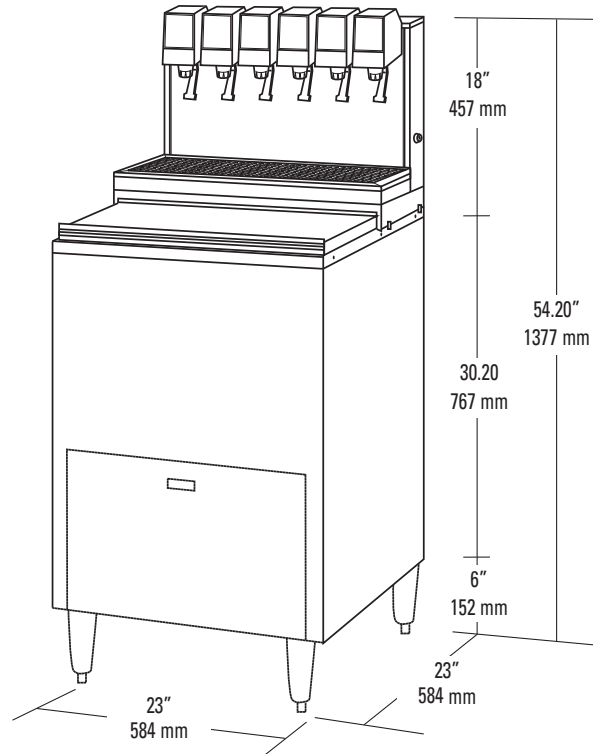

DIMENSIONS

Width: 23 in (584 mm)
 Depth: 23 in (584 mm)
 Height: 54.20 in (1377 mm)

COUNTER CUT-OUT

Width: 23.25 in (591mm)
 Deep: 24 in (603mm)

ELECTRICAL

24VAC/60Hz

WEIGHT

Operating: 290 lbs (132 kg)
 Shipping: 196 lbs (89 kg)

ICE

Capacity: 100 lbs (45 kg)

FITTINGS

Soda inlets: 3/8" male barb
 Syrup inlets: 3/8" male barb

VALVES

LEV® and other valves available upon request

FLEX MANIFOLD CONFIGURATION

6 valve 3-2-1
 8 valve 3-1-1-3

KEY LOCK SWITCH

DRAW PERFORMANCE

Number of Drinks Below 40°F

75°F (24°C) Ambient Temperature

12 oz./12 drinks per minute
 24 oz./7 drinks per minute

90°F (32°C) Ambient Temperature

12 oz./8 drinks per minute
 24 oz./5 drinks per minute

Units can supply drinks under 40°F at rated draw performance continuously as long as ice is kept on cold plate.

Warranty: For warranty specifics by product, contact your Lancer Sales Representatives.

Equipment design and/or specifications may change without notice.

CORPORATE OFFICE 6655 Lancer Blvd - San Antonio, TX 78219
 210-310-7000 - 1-800-729-1500 - FAX 210-310-7250 - www.lancercorp.com

"Lancer" is the registered trademark of Lancer Corporation © 2010 Lancer, all rights reserved.

ICD 2400 CC Spec Sheet 07/10