



Positive displacement low volume flowmeter for continuous measurement

- For highly viscous fluids
- Available for indication, monitoring, transmitting, On/Off control together with 8025 or 8619 and/or batch control together with 8025

Type 8071 can be combined with...



Type 8025

Universal flow transmitter



Type 8619

multiCELL transmitter/controller



Type 2101 (8692)

Continuous TopControl system

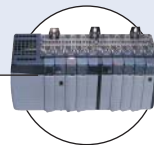

PLC

This positive displacement flowmeter is specially designed for measurement or batch control (if combined with 8025/8619) of highly viscous fluids like glue, honey or oil.

The design of this low flowmeter is based on the oval rotor principle. This has proven to be a reliable and highly accurate volumetric method of measuring flow. Exceptional repeatability and high accuracy over a wide range of viscosities and flowrates are features of that design. The low pressure drop and high pressure rating make it suitable for both gravity and pump (in-line) applications.

All 8071 devices provide Open Collector NPN frequency output and frequency output on Reed contact via 1 meter 5-wire cable with open ends.

General data

Compatibility

with Type 8025 Universal transmitter/batch controller or Typ 8619 multiCELL transmitter/Controller (see corresponding data sheet)

Materials

Body: Aluminium, PPS, stainless steel 316F (1.4401)
 Rotor: PPS, stainless steel 316F (1.4401)
 Shaft: Hastalloy C, PPS, stainless steel 316F (1.4401)
 Seal: FKM or FFKM

Electrical connections

5-wire cable, 1 m length

Environment

Ambient temperature

(operating and storage)
 Aluminium or PPS body: +80°C (176°F) max.
 Stainless steel body: +120°C (248°F) max.

Relative humidity

≤ 85%, without condensation

Complete device data	
Process connection	Thread 1/8"; 1/4" (G or NPT)
Measuring range	0.5 to 500 l/h (0.13 to 132 gph)
Medium temperature max.	Aluminium or PPS body: 80°C (176°F) Stainless steel body: 120°C (248°F)
Medium pressure max.	Aluminium or PPS body: 5 bar (72 PSI) Stainless steel body: 55 bar (798 PSI) (550 bar (7980 PSI) on request)
Viscosity	1 Pa.s. max. (higher on request)
Max. particle size	75 µm - To prevent damage from dirt or foreign matter, we strongly recommend the installation of a 75 µm (200 mesh) strainer as close as possible to the inlet side of the meter.
Accuracy	≤ ± 1% of Reading
Repeatability	≤ 0.03% of Reading
Electrical data	
Sensor type	Hall effect sensor or Reed contact
Current consumption	≤ 9 mA (Hall effect sensor)
Output frequency	Open collector, NPN, max. 25 mA, 4.5 to 24 V DC switching voltage 30 V DC max. current, 0.5 A
Hall effect sensor	
Reed contact	
K-factor	1000 pulses/l 400 pulses/l
0.5-100 l/h	
15-500 l/h	
Standards, directives and approvals	
Protection class	IP54 (NEMA 13)

Dimensions [mm]

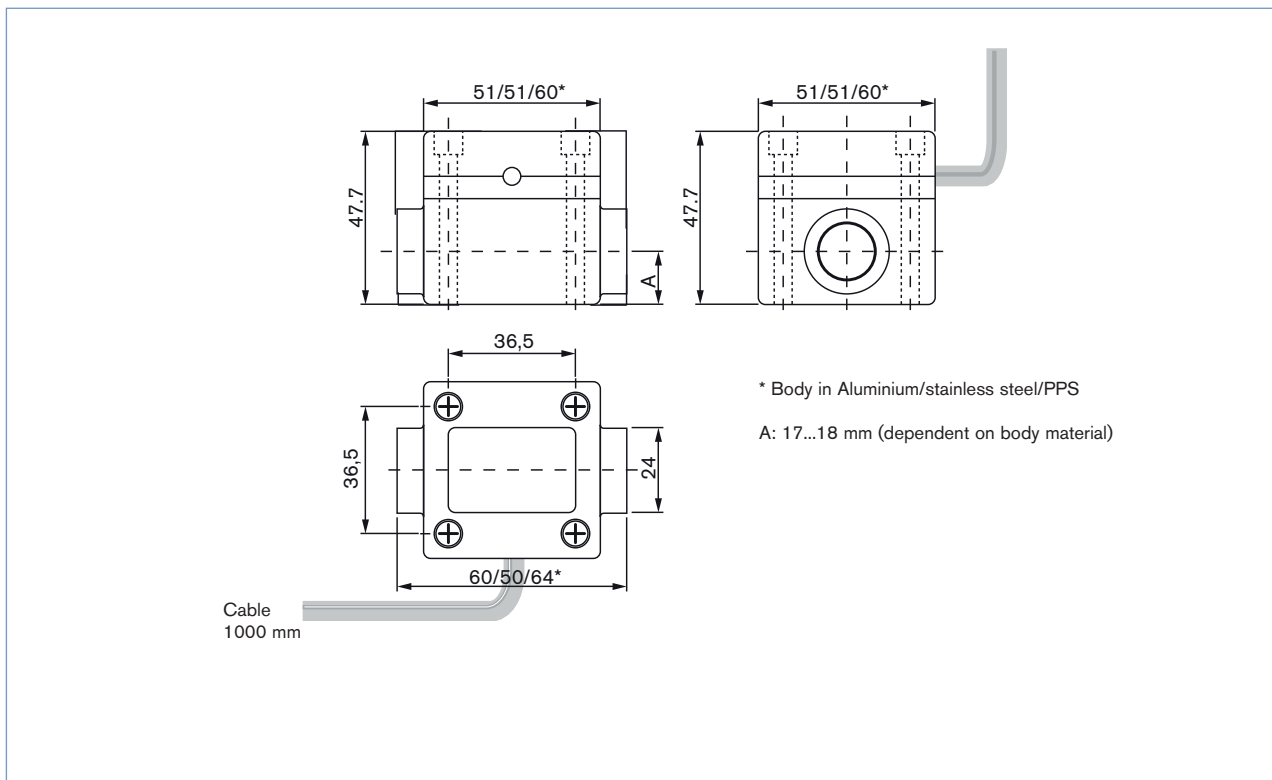

Ordering chart for flowmeter Type 8071

Process connection	Flow Range		Body material	Max. pressure	Rotor / shaft material	Seal	Item no.
	> 5 mPa.s.	< 5 mPa.s.					
G 1/8	0.5-100 l/h (0.13 to 26.4 gph)	2-100 l/h (0.53 to 26.4 gph)	Aluminium	5 bar	Stainless steel	FKM	565 117
			Stainless steel	55 bar	Stainless steel	FFKM	565 118
NPT 1/8	0.5-100 l/h (0.53 to 26.4 gph)	2-100 l/h (0.53 to 26.4 gph)	Aluminium	5 bar	Stainless steel	FKM	565 119
			Stainless steel	55 bar	Stainless steel	FFKM	565 120
G 1/4	0.5-100 l/h (0.13 to 26.4 gph)	2-100 l/h (0.53 to 26.4 gph)	PPS	5 bar	PPS / Hastalloy C	FFKM	432 288
			Stainless steel	55 bar	Stainless steel	FFKM	433 864
	15-500 l/h (4.00 to 132 gph)	40-500 l/h (10.56 to 132 gph)	PPS	5 bar	PPS / Hastalloy C	FFKM	430 856
			Stainless steel	55 bar	Stainless steel	FFKM	437 518
	15-500 l/h for high viscosity*		Stainless steel	55 bar	Stainless steel	FFKM	552 426
	NPT 1/4	0.5-100 l/h (0.53 to 26.4 gph)	2-100 l/h (0.53 to 26.4 gph)	PPS	5 bar	PPS / Hastalloy C	FFKM
Stainless steel				55 bar	Stainless steel	FFKM	448 656
15-500 l/h (4.00 to 132 gph)		40-500 l/h (10.56 to 132 gph)	PPS	5 bar	PPS / Hastalloy C	FFKM	448 655
			Stainless steel	55 bar	Stainless steel	FFKM	448 657
15-500 l/h for high viscosity*		Stainless steel	55 bar	Stainless steel	FFKM	553 652	

* > 1 Pa.s.

Ordering chart for accessories

Description	Item no.
Set of two rotors in stainless steel for measuring range 0.5-100 l/h	550 919
Set of two rotors in stainless steel for measuring range 15-500 l/h	550 920
Set of two rotors in PPS for measuring range 0.5-100 l/h	550 921
Set of two rotors in PPS for measuring range 15-500 l/h	550 922
FKM seal	550 923
FFKM seal	550 959
Set of stainless steel cap with hall sensor and Reed contact	553 653
Set of PPS cap with hall sensor and Reed contact	553 654
Set of aluminium cap with hall sensor and Reed contact	565 469

 Further versions on request

Materials

Set of aluminium steel cap with hall sensor and Reed contact

To find your nearest Bürkert office, click on the orange box →

www.burkert.com
In case of special application conditions,
please consult for advice.Subject to alteration
© Christian Bürkert GmbH & Co. KG

1607/15_EU-en_00891792