

Installation Manual

eSENSE Outdoor™

CO₂ transmitter with heater and inline thermostat mounted in IP65 housing

eSENSE Outdoor Product # SE-0036



The *eSENSE Outdoor* PCB is housed in an IP65 housing with breathers to support the flow of outdoor air. If for some reason the PCB must be removed care must be taken to protect from electrostatic discharge! Normally, removing the PCB is NOT required.

The eSENSE Outdoor includes an in-line thermostat in order that heating of the housing only takes place when the outdoor temperature warrants the use of the energy to maintain an above freezing temperature in the housing. Maintaining an above freezing temperature prevents the accumulation of ice crystals inside the Optical Bench Assembly, which could cause inaccurate CO2 measurements.

Electrical connections



The power supply must be connected to + and \perp is considered as system ground. If the analogue output is connected to a controller *the same ground reference has to be used for the eSENSE unit and for the control system!* Unless different transformers are used, special precautions need to be taken.

PLEASE NOTE! The eSENSE signal ground is not galvanically separated from the eSENSE power supply!



Please NOTE!

The same ground reference has to be used for the eSENSE unit and for the control system!

The eSENSE Outdoor can be mounted to a wall or other supporting structure using the four corner mounting holes or the top and bottom mounting holes.

Connection of Power to Terminal 1 and Ground to Terminal 2 must maintain the 2 connections associated with the heater. The eSENSE Outdoor is shipped with the heater connections already in place for ease of installation.

Notice

This product is in accordance with the EMC 2004/108/EC, 92/31/EEG including amendments by the CE-marking Directive 93/68/EEC.

The product fulfils the following demands: EN 61000-4-2 level 2, EN 61000-4-3 level 2, EN 61000-4-4 level 4, EN 61000-4-6, EN 61000-4-8 level 4, EN 55022 class B



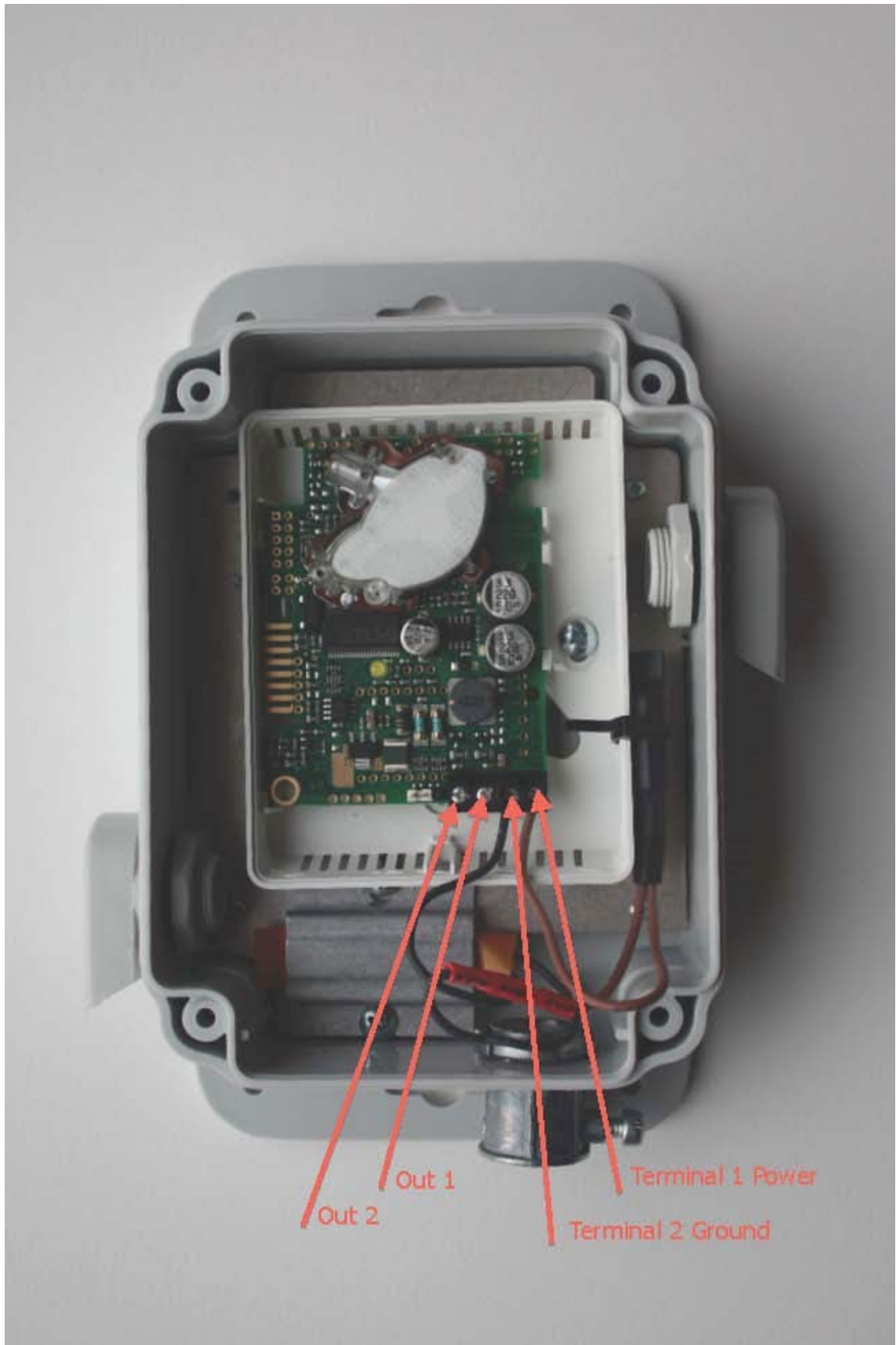

Connect the power after mounting.

eSENSE Outdoor™ carbon dioxide transmitter Technical Specifications

General Performance

Compliance with	EMC directive 89/336/EEC. RoHS directive 2002/95/EG
Operating Temperature Range	-22 to +115 °F
Storage Temperature Range	-4 to +122 °F ¹
Operating Humidity Range	0 to 95% RH (non-condensing)
Operating Environment	Outdoor
Warm-up Time	< 1 min. (@ full specs < 15 minutes)
Sensor Life Expectancy	> 15 years
Maintenance Interval	no maintenance required
Self Diagnostics	complete function-check

Electrical

Power Input	24 VAC/VDC ±20%, 50 Hz (half-wave rectifier input)
Power Consumption	< 1 Watt average (Heater Off)
Connection screw terminal A	4 x 1,5 mm ² for power input (G+, G0) and voltage outputs (OUT1, OUT2)

CO₂ Measurement

Sensing method	Infrared (NDIR) waveguide technology with Automatic Baseline Correction (ABC) and passive gas diffusion (no moving parts)
Response Time (T _{1/e})	< 30 sec. @ 30 cc/min. flow rate, < 3 min. diffusion time
Repeatability	± 20 ppm ± 1 % of reading
Accuracy ³	± 30 ppm ± 3 % of reading
Annual Zero Drift ³	< ± 10 ppm
Pressure Dependence	+1.6% of reading per kPa deviation from normal pressure 101.3kPa ⁴

Outputs

Output signal terminal CO₂⁵

OUT1 linear conversion range.....	0 - 10 VDC for 0 - 2 000 ppm.
OUT2 linear conversion range.....	4 - 20 mA or 2 - 10VDC for 0 - 2 000 ppm.
.....	D/A resolution 10 bits, 10 mV
D/A conversion accuracy.....	± 2 % of reading ± 50 mV
Electrical characteristics.....	R _{OUT} < 100 Ohm, R _{LOAD} > 5 kOhm (Heater Off)

Note 1: After long-term storage a zero calibration is recommended.

Note 2: All corrosive environments are excluded.

Note 3: Accuracy is defined after zero calibration or after minimum 23 days of continuous operation. The tolerance of the span gas (2% unless otherwise requested) and test gas adds to the total uncertainty.

Note 4: For reference see TN-025 "on pressure sensitivity".

Note 5: The specifications are valid for the output load connected to Ground G0.

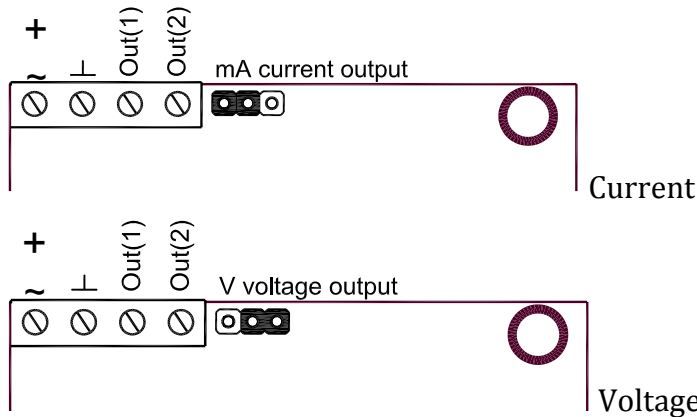

Figure 1 Picture of the PCB with the jumper for setting Out(2) to current output (left position) or voltage output (right position)

Electrical connections



The power supply must be connected to \sim and \perp . \perp is considered as system ground. The same ground reference has to be used for the eSENSE unit and for the DDC/signal receiver.

PLEASE NOTE! The same ground reference has to be used for the eSENSE unit and for the control system!

Connection Terminal	Function	Electrical Data	Remarks
\sim +	Power (+)	24 VAC/DC+ (+/-20%), 2W	
	Power ground (-)	24 VAC/DC-	
Out(1)	Analogue Output 1 (+)	0-10 VDC	0-2000 ppm CO ₂
Out(2)	Analogue Output 2 (+)	2,0-10,0 VDC or 4,0-20,0 mA	0-2000 ppm CO ₂
		0,9-1,6 VDC or 1,5-2,5 mA	Status = ERROR
		0 VDC or 0mA	Status = NOT READY

Table I. Electrical terminal connections for eSENSE

Support

The quickest way to obtain technical support is via email. Please send all support inquiries to support@co2meter.com.

Please include a clear, concise definition of the problem and any relevant troubleshooting information or steps taken so far, so we can duplicate the problem and quickly respond to your inquiry.

Warranty

This meter comes with a 1 YEAR (warranty period) limited manufacturer's warranty, starting from the date the meter was shipped to the buyer.

During this period of time, CO2Meter.com warrants our products to be free from defects in materials and workmanship when used for their intended purpose and agrees to fix or replace (at our discretion) any part or product that fails under normal use. To take advantage of this warranty, the product must be returned to CO2Meter.com at your expense. If, after examination, we determine the product is defective, we will repair or replace it at no additional cost to you.

This warranty does not cover any products that have been subjected to misuse, neglect, accident, modifications or repairs by you or by a third party. No employee or reseller of CO2Meter.com's products may alter this warranty verbally or in writing.

Liability

All liabilities under this agreement shall be limited to the actual cost of the product paid to CO2Meter.com. In no event shall CO2Meter.com be liable for any incidental or consequential damages, lost profits, loss of time, lost sales or loss or damage to data, injury to person or personal property or any other indirect damages as the result of use of our products.

Returns

If the product fails under normal use during the warranty period, a RMA (Return Material Authorization) number must be obtained from CO2Meter.com. After the item is received CO2Meter.com will repair or replace the item at our discretion.

To obtain a RMA number, call us at or email us at (386) 256-4910 support@co2meter.com. When requesting a RMA please provide reason for return and original order number.

If we determine that the product failed because of improper use (water damage, dropping, tampering, electrical damage etc.), or if it is beyond the warranty date, we will inform you of the cost to fix or replace the product.

For more information visit our website: www.CO2Meter.com/pages/faq

Contact Us

We are here to help! For information or technical support, please contact us.

support@co2meter.com
(386) 256-4910 (Technical Support)
(386) 872-7665 (Sales)
www.co2meter.com

Address:
CO2Meter, Inc.
131 Business Center Drive
Ormond Beach, FL 32174
USA