

# CO2+VOC + RH/T Monitor/Alarm

**Model: TON-0003**

## Important Safety Information

- ◆ Always cut off power before mounting, removing, and cleaning the monitor.
- ◆ Notice the supply power voltage of the monitor is 100~240VAC.

### Mounting

- ◆ Mount the monitor on the wall, 1.2-1.3 meters above the floor. Do not behind a door, in a corner, near diffuser, in direct sunlight, and near any heat or steam sources, and do not install near trash can, gas cooker or a ventilation.

### Operation

- ◆ Turn on the power, a red light at middle bottom of the cover is flickering. The LCD backlit turn to green. See Fig1 the measured temperature and the relative humidity displays on the upper line of the LCD and the measured CO2 display in the middle of the LCD, measured TVOC high/middle/ low displays in the bottom of the LCD. Power off , OFF will appear at the right bottom of the LCD

## Mounting

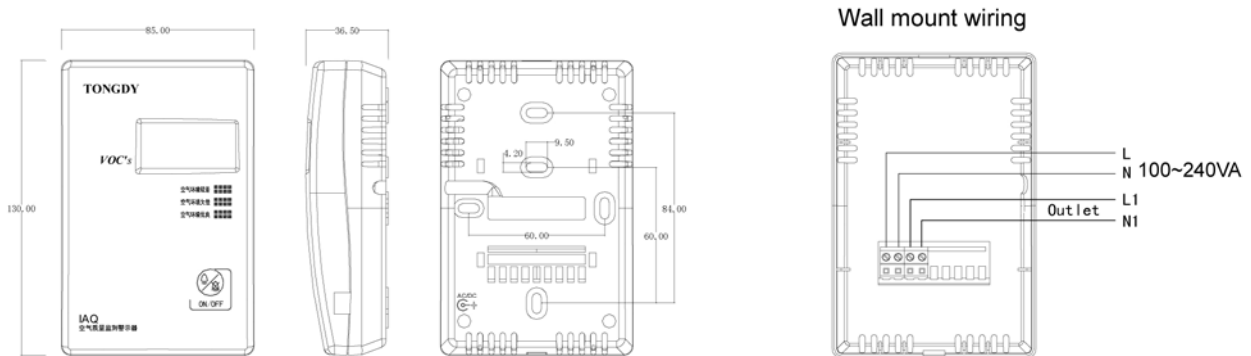

Wall mounting-base bracket

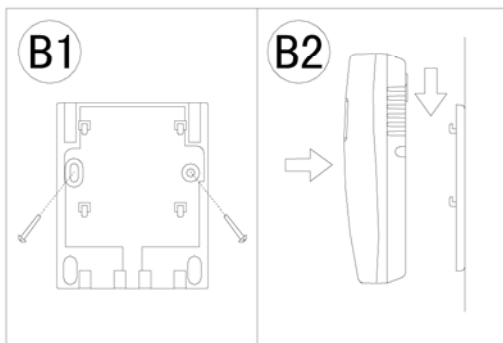

Desktop- bracket

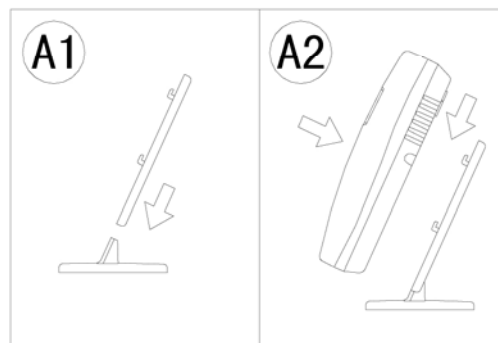

## LCD display

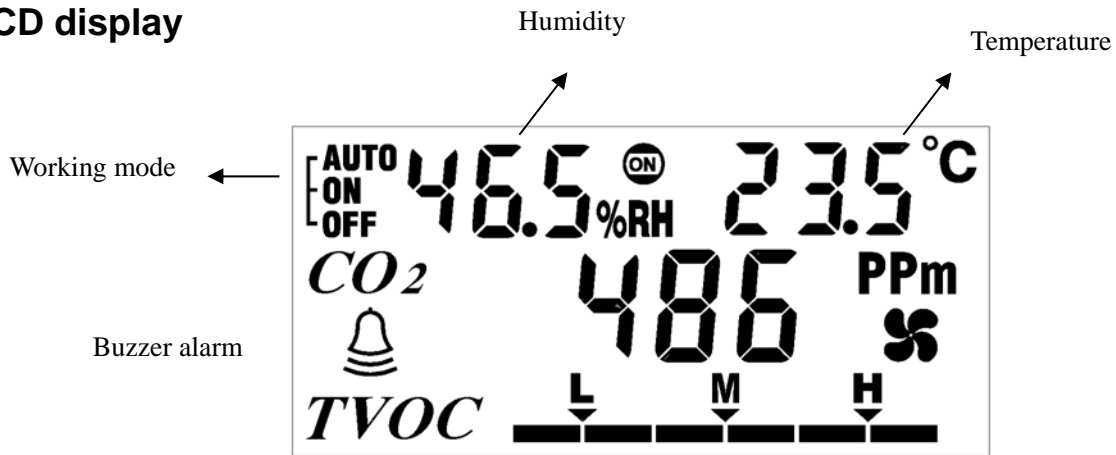

## Wiring Diagram

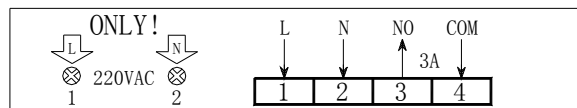

- ◆ The CO2 measurement increases from 0.0, when it keeps stable, the value indicates the CO2 concentration. The warm up time is around 2 hours for the first time power on, or after power off for a long time (one month); normally it needs 3 minutes to warm up and keep work stable.
- ◆ When the relay is on, the LCD screen will display "ON". When the relay is off, the LCD screen will not display "ON".
- ◆ The setting point of the backlit and the buzzer alarm:
  - Backlit monitoring point:
    - The backlit is green: CO2 level <1000ppm, at the mean time VOC level <12ppm
    - The backlit turns into yellow: CO2 level >1000ppm or VOC level >12ppm
    - The backlit turns into red from yellow: CO2 level >1400ppm or VOC level >20ppm and measurement value blinks to alarm the poor air quality.
    - The backlit turns into yellow from red: CO2 level <1400ppm, in the meantime VOC level < 20ppm.
  - Buzzer alarm point: when CO2>1800ppm, the alarm working, CO2<1780ppm the alarm stop. When VOC>25ppm, the alarm is working, VOC<24.5ppm the alarm stops.

- ◆ Touch button: the touch button is used to operate the monitor as shown in the table below: Touch button ,the circle order:  
AUTO+ON->.AUTO+OFF-> ON-> OFF->POWER OFF

LCD display	Buzzer Alarm	Alarm icon
AUTO+ON	Valid	Appear
AUTO+OFF	Invalid	Disappear
ON	Invalid	Disappear
OFF	Invalid	Disappear

## Advanced Setup

When power off, removing the backboard and clapboard from the main part. There are 4 DIP switches. When up the switch is "ON"; when down it is "OFF".

DIP1-1: ON- Parameter setup                  OFF- Normal use

DIP1-2: ON- Fahrenheit                      OFF- Centigrade

DIP2-1: OFF- choose CO2 to control the setting point 1 to control the relay.

ON- choose CO2 to control the setting point 2 to control the relay

For the controlling setting point 1 to control the relay, when CO2>1000ppm, the relay is open. When CO2<=950ppm, the relay is off.

For the controlling setting point 2 to control the relay, when CO2>1400PPM, the relay is open. When CO2<=1350ppm, the relay is off.

DIP2-2: OFF-- Choose VOC to control setting point 1 to control the relay.

ON-- Choose VOC to control setting point 2 to control the relay.

For choosing VOC to control the setting point 1 to control the relay, when VOC >15PPM , the relay is on; when VOC<=13ppm, the relay is off.

For choosing VOC to control the setting point 2 to control the relay, when VOC >20PPM, the relay is on; when VOC <18ppm, the relay is off.

## Change Defaults

Set DIP1 on (up). Power the unit and you can change the preferences below:

As you change the parameters, the flashing number means “not ready.” You MUST wait until the number stops flashing. This means the setting has changed.

LCD uplink display	Parameter	settings' arrangement	default
-1	temperature correction	+ - 3 .0C/+ - 6 .0F	0.0C/0.0F
-2	humidity correction	+ - 5 .0%RH	0.0 %RH
-3	VOC correcting objectives	0.0 ~ 3 0.0ppm	1 5 .0ppm
-4	VOC controlling relay setting point 1	0.0 ~ 3 0.0ppm	1 5.0 ppm
-5	VOC controlling relay setting point 2	0.0 ~ 3 0.0ppm	2 0.0 ppm
-6	VOC controlling backlit green<--->yellow changing the setting point	0.0 ~ 3 0.0ppm	1 2 .0 ppm
-7	VOC controlling backlit yellow <---> red changing the setting point	0.0 ~ 3 0.0ppm	2 0.0 ppm
-8	VOC control buzzer alarm setting point	0.0 ~ 3 0.0ppm	2 5 .0 ppm
-9	VOC zero calibration desired value		5.0ppm
-10	CO2 calibration value	+ -200ppm	0ppm
-11	CO2 controlling relay setting 1	1 ~ 2 000ppm	1 000 ppm
-12	CO2 controlling relay setting point 2	1 ~ 2 000ppm	1 4 00 ppm
-13	CO2 controlling relay setting point differential	1 ~ 1 00 ppm	50 ppm
-14	The backlit controlling source options	1- not light 2-green light 3-yellow light 4-red light 5-CO2 control green/yellow/red automatic changeable 6-VOC control green/yellow/red automatic changeable 7-CO2 VOC control green/yellow/red automatic changeable	7
-15	CO2 controlling backlit green<--->yellow change the setting point	1 ~ 2000ppm	1 000 ppm
-16	CO2 controlling backlit yellow<--->red change the	1 ~ 2000ppm	1400 ppm

	setting point		
-17	CO2 control buzzer alarm setting point	1 ~ 2000ppm	1800 ppm
-18	The buzzer alarm voice choices	0-there comes the voice 1- Kachusha 2- the wedding in the dream 3-For Alice 4- the voice of "di"	4
-19	The choice of the alarm sources for the buzzer alarm	1-when the measurement of CO2 is high, here comes the alarm 3-when the CO2 or VOC is high, here comes the alarm or when the measurement of the VOC is high, here comes the alarm.	3
-20	sensor the warming up time after the electricity is on	1~600 seconds(during these process, here avoid the relay and the output of the alarm)	180
-21	the choices for the on and off for the device	0-off 1-on 2-keeping the status of the opening and closing of the machine	2
-22	adjusting the maximum luminance of the green backlit	0~100	100
-23	adjusting the maximum luminance of the red backlit	0~100	100
-24	VOC AD adjusting value	-500~500	0
-25	limiting the maximum measurement value of CO2	1~9999	2000
-26	CO2 module measurement value self-correcting option	1- allow self-correction 2- not allowing self-correction	1
-27	CO2 module and the modification of the height level	T6603 0~9999feet	0
-28	model options	1-without relay 2- with relay	2

# Specifications

Monitoring parameters	CO <sub>2</sub>	VOC	Temperature	Relative humidity
<b>Sensing element</b>	Non-Dispersive Infrared Detector (NDIR)	Semiconductor mix gases sensor	Digital combined temperature and humidity sensor	
<b>Measuring range</b>	0~5000ppm	1~30ppm	0~50°C	0~100%RH
<b>Display Resolution</b>	1ppm	5ppm	0.1°C	0.1%RH
<b>Accuracy@25°C(77°F)</b>	±60ppm + 3% of reading	±10%	±0.5°C	±4.5%RH
<b>Life time</b>	15 years (normal)	5~7 years	10 years	
<b>Stability</b>	<2%	—	<0.04°C per year	<0.5%RH per year
<b>Calibration cycle</b>	ABC Logic Self Calibration ( No client separate calibration)	—	—	—
<b>Response Time</b>	<2 minutes for 90% change	<1 minute (for 10ppm hydrogen, 30ppm ethanol) <5 minute (for a cigarette) in 20m <sup>2</sup> room	<10 seconds to reach 63%	
<b>Warm up time</b>	72 hours (first time) 10 minutes (operation)			
Electrical Characteristics				
<b>Power supply</b>	100~240VAC			
<b>Consumption</b>	3.5 W max. ; 2.5 W avg.			
Display and Alarm				
<b>LCD Display</b>	<p><b>Green:</b> CO<sub>2</sub>&lt;1000ppm (optimal air quality) TVOC: — or — — (low pollution)</p> <p><b>Yellow:</b> CO<sub>2</sub>&gt;1000ppm (moderate air quality) TVOC: — — — or — — — — (medium pollution)</p> <p><b>Red:</b> CO<sub>2</sub>&gt;1400ppm (poor air quality) TVOC: — — — — — or — — — — — — (heavy pollution)</p> <p>Two modes selectable: both CO<sub>2</sub> and TVOC over the above set points (default) Either CO<sub>2</sub> or TVOC over the above set point</p>			
Conditions of Using and Installation				
<b>Operation conditions</b>	-10~50°C(14~122°F); 0~95%RH, non condensing			
<b>Storage conditions</b>	0~50°C(32~122°F)/ 5~90%RH			
<b>Weight</b>	200g			
<b>Dimensions</b>	130mm(L)×85mm(W)×36.5mm(H)			
<b>Installation</b>	Desktop or wall mount (65mm×65mm or 85mm×85mm or 2"×4" wire box)			
<b>Housing IP class</b>	PC/ABS, protection class: IP30			

## Support

The quickest way to obtain technical support is via email. Please send all support inquiries to [support@co2meter.com](mailto:support@co2meter.com).

Please include a clear, concise definition of the problem and any relevant troubleshooting information or steps taken so far, so we can duplicate the problem and quickly respond to your inquiry.

## Warranty

This unit comes with a 1YEAR (warranty period) limited manufacturer's warranty, starting from the date the unit was shipped to the buyer.

During this period of time, CO2Meter.com warrants our products to be free from defects in materials and workmanship when used for their intended purpose and agrees to fix or replace (at our discretion) any part or product that fails under normal use. To take advantage of this warranty, the product must be returned to CO2Meter.com at your expense. If, after examination, we determine the product is defective, we will repair or replace it at no additional cost to you.

This warranty does not cover any products that have been subjected to misuse, neglect, accident, modifications or repairs by you or by a third party. No employee or reseller of CO2Meter.com's products may alter this warranty verbally or in writing.

## Liability

All liabilities under this agreement shall be limited to the actual cost of the product paid to CO2Meter.com. In no event shall CO2Meter.com be liable for any incidental or consequential damages, lost profits, loss of time, lost sales or loss or damage to data, injury to person or personal property or any other indirect damages as the result of use of our products.

## Returns

If the product fails under normal use during the warranty period, a RMA (Return Material Authorization) number must be obtained from CO2Meter.com. After the item is received CO2Meter.com will repair or replace the item at our discretion.

To obtain a RMA number, call us at or email us at (386) 256-4910 [support@co2meter.com](mailto:support@co2meter.com). When requesting a RMA please provide reason for return and original order number.

If we determine that the product failed because of improper use (water damage, dropping, tampering, electrical damage etc.), or if it is beyond the warranty date, we will inform you of the cost to fix or replace the product.

## Contact Us

### We are here to help!

For information or technical support, please contact us.

 [support@co2meter.com](mailto:support@co2meter.com)

 (386) 256-4910 ( Technical Support)

 (386) 872-7665 (Sales)

 [www.co2meter.com](http://www.co2meter.com)

Address:

CO2Meter, Inc.

131 Business Center Drive

Ormond Beach, FL 32174 USA