



Cert. No. LRQ 0963008

ISO 9001

spirax/sarco

TI-P370-14
CH Issue 6

PP5

Pneumatic / Pneumatic Positioner

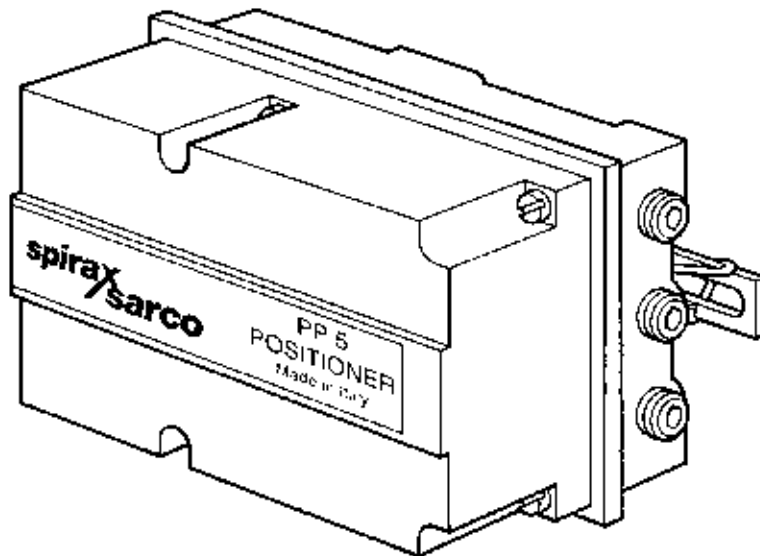

Description

The PP5 positioner is a single acting unit, requiring a 0.2 to 1 bar signal and is for use with linear pneumatic actuators. The positioner compares the output signal from a pneumatic controller (or transducer) with the valve position feedback, and varies the pneumatic output signal to the actuator accordingly. The valve position is, therefore, guaranteed for any controller output signal and the effects of varying valve differential pressure, stem friction and diaphragm hysteresis are overcome. The positioners can also be used where the controller output signals are of too low a magnitude to be used directly with high pressure actuators. A mounting kit is supplied with each positioner for mounting to either columns or yoke in accordance with NAMUR standard. Safety covers are provided.

Applications

The positioners can be used with the following actuators:

Actuator types	
	PN9000 Series
	TN2000 Series

Technical data

Input signal range	0.2 bar to 1 bar
Output signal range	0 to 100% supply air pressure
Supply air pressure	1.4 bar to 6 bar
Stroke range	10 mm to 100 mm
Amplification	Adjustable
Enclosure rating	IP65
Air consumption	0.7 m ³ /h at 6 bar
Pneumatic connections	¼" NPT
Ambient conditions	-20°C to +80°C

Materials

Body and cover	Die cast aluminium with anti-corrosive paint
----------------	--

Accessories

A fixing kit is available to mount an air filter/regulator to the pneumatic actuator.

Fixing kit	Actuator type
FK21	PN9100 Series
FK28	PN9200 or PN9300 Series

How to order

Example: 1 off Spirax Sarco PP5 pneumatic/pneumatic positioner.

Dimensions (approximate) in mm

Weight 2.8 kg

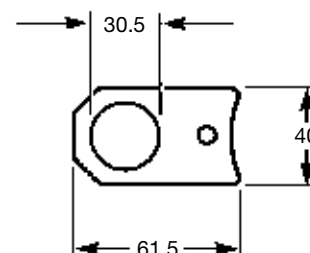
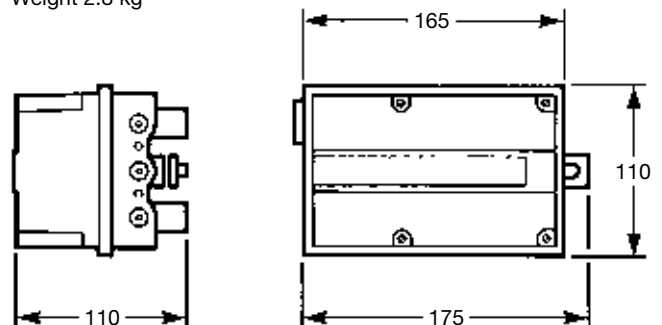

FK21 / FK28 fixing kit

Installation

Full details are contained in the appropriate Installation and Maintenance Instructions supplied with the product.

Air connections (rear view)

Air connection 1/4" NPT

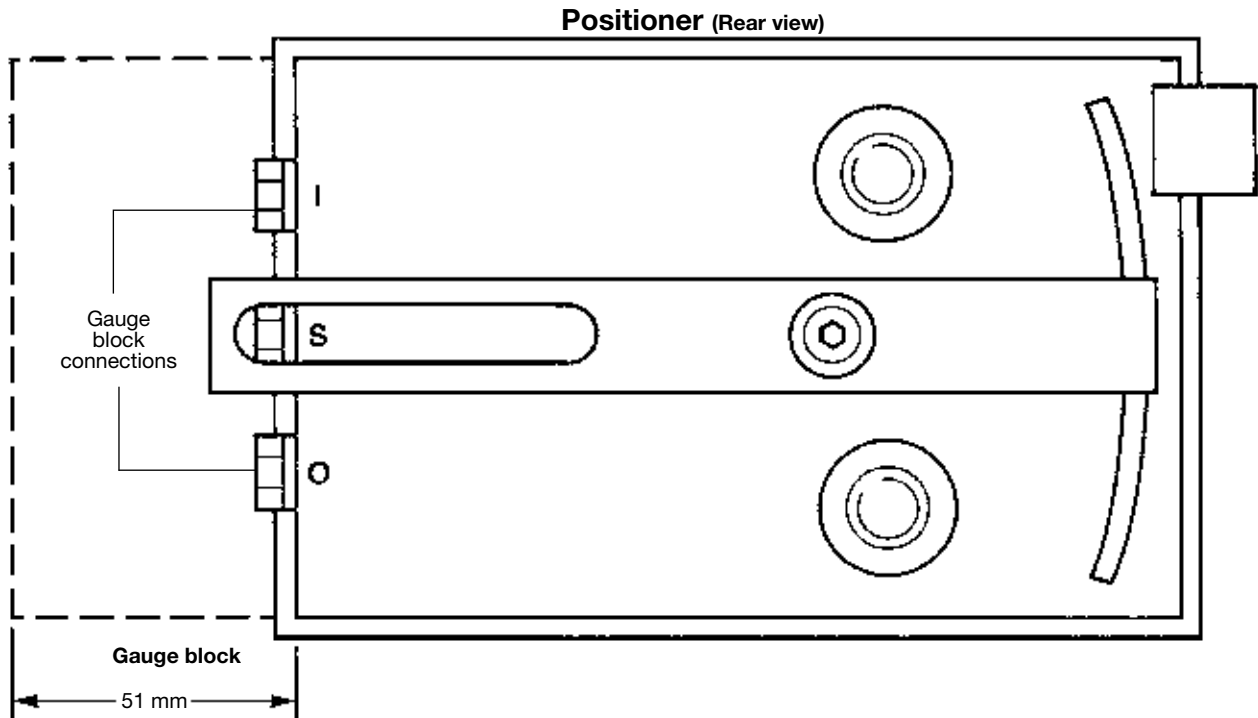

Spares

Gauge	0-2 bar output
Gauge	0-4 bar output
Gauge	0-7 bar output
Springs and pneumatic tube set	
Set of gaskets, diaphragms and orifice	
Amplifying relay set	
Block for gauges	

