



TI-P017-07
 ST Issue 13

AE30, AE30A, AE30B and AE30C Automatic Air Eliminators/ Air and Gas Vents for Liquid Systems

Description

The AE30 range of automatic air eliminators/air and gas vents are designed for use on liquid installations. The body and the cap are made from a special brass alloy, which is dezincification resistant (DZR).

Available options

AE30	Air eliminator/air vent
AE30A	Air eliminator/air vent with check valve
AE30B	Air eliminator/air vent with lockshield
AE30C	Air eliminator/air vent with check valve and lockshield

The fitted lockshield valve (versions AE30B and AE30C) has a unique 3 way locking system enabling the valve to be either locked open, locked closed or be used as conventional ball valve. You will need to use a standard socket set (not included with the product) to operate the valve.

Standards

This product fully complies with the requirements of the European Pressure Equipment Directive 97/23/EC.

Certification

This product is available with a manufacturer's Typical Test Report.
Note: All certification/inspection requirements must be stated at the time of order placement.

Sizes and pipe connections

AE30, AE30A: Inlet 1/2" female, outlet 1/4" male both BSP or NPT.
AE30B, AE30C: Inlet 1/2" male, outlet 1/4" male both BSP.

Pressure/temperature limits

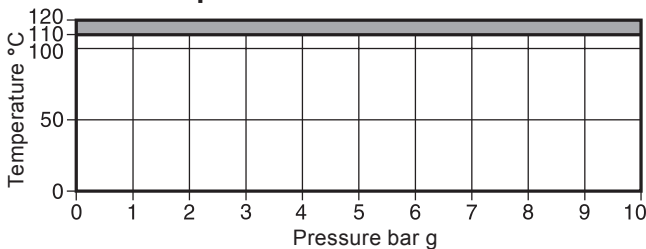

The product **should not** be used in this region as damage to the internals may occur.

Body design conditions	PN10
PMA Maximum allowable pressure	10 bar g @ 120°C
TMA Maximum allowable temperature	120°C @ 10 bar g
Minimum allowable temperature	-10°C
PMO Maximum operating pressure	10 bar g @ 110°C
TMO Maximum operating temperature (at all pressures)	110°C
ΔPMX Maximum differential pressure	8 bar g @ 110°C
Minimum operating temperature	0°C
Designed for a maximum cold hydraulic test pressure of	15 bar g
Minimum specific gravity of liquid	0.926

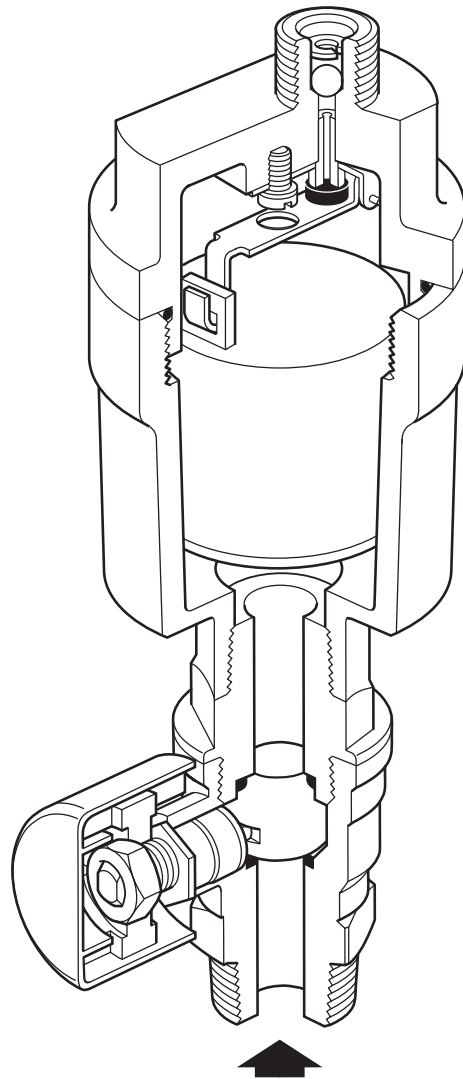

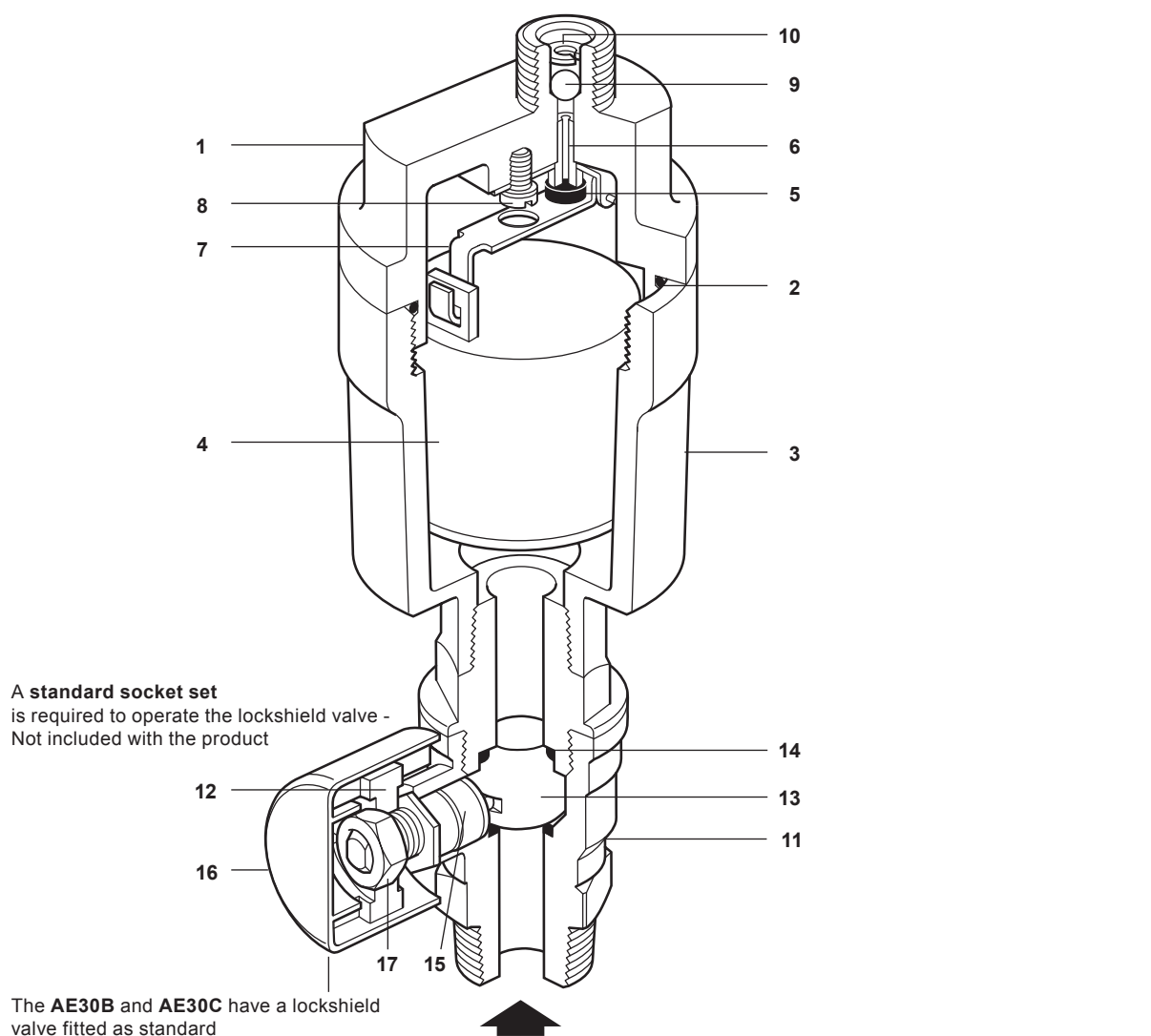

Materials

No.	Part	Material	
1	Cap	DZR brass alloy	BS 2872 CZ 132
2	Cap 'O' ring	Green Viton 75	
3	Body	DZR brass alloy	BS 2872 CZ 132
4	Float	Acetal co hostaform/stainless steel	
5	Valve cone	EPDM or Green Viton (IRHD 50-55)	
6	Valve seat	Stainless steel	BS 970 431 S29
7	Bracket/lever assembly	Stainless steel	BS 1449 304 S11
8	Screw	Stainless steel	BS 4183 18/8
9	Check valve ball	(AE30A and C)	Stainless steel AISI 440 B
10	Circlip	(AE30A and C)	Stainless steel BS 970 302 S25
11	Lockshield valve body	(AE30B and C)	DZR brass alloy EN 12165 CW 602N
12	Lockshield valve		Hard Cr. DZR alloy EN 12165 CW 602N
13	Ball	(AE30B and C)	Hard Cr. DZR alloy EN 12165 CW 602N
14	Seal	(AE30B and C)	Virgin PTFE
15	Stem seal	(AE30B and C)	Virgin PTFE
16	Cover	(AE30B and C)	Polypropylene
17	Hex-nut	(AE30B and C)	Zinc plated steel

Free discharge capacity

For air at 16°C

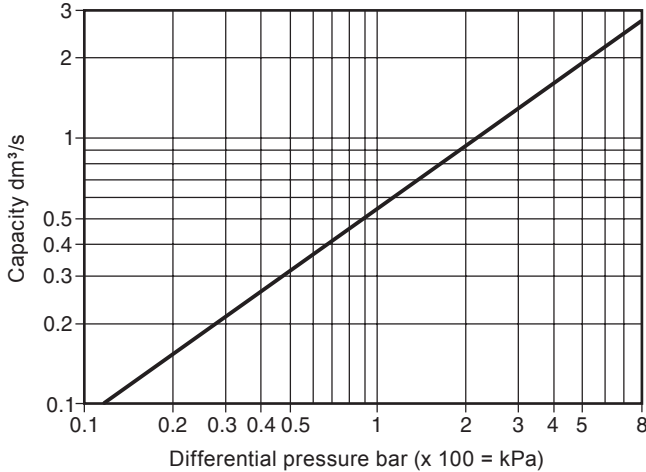

If the temperature of the air differs from 16°C, the discharge capacity from the graph can be corrected by multiplying it by the following equation:

$$\frac{289}{273 + T} \quad (T \text{ is the actual temperature in } ^\circ\text{C})$$

It may be assumed that the temperature of the air is equal to the temperature of the water.

Dimensions/weight (approximate) in mm and kg

Version	A	B	C	D	Weight
AE30, AE30A	56	105	10	-	0.7
AE30B, AE30C	56	105	10	155	0.9

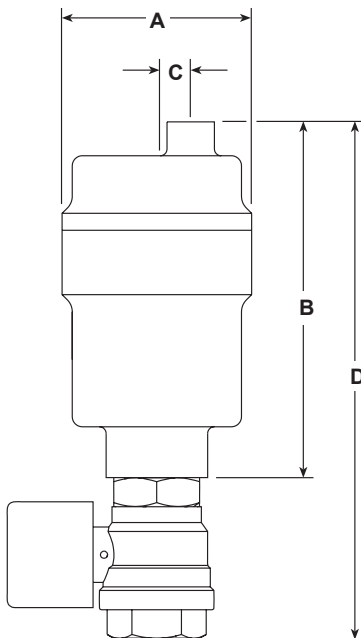

Safety information, installation and maintenance

For full details see the Installation and Maintenance Instructions (IM-P017-08) supplied with the product.

Installation note:

The automatic air eliminator/air vent should be installed vertically with the inlet at the bottom. We recommend piping the discharge from the air eliminator/air vent to a suitable drainpoint.

How to order

Example: 1 off Spirax Sarco ½" AE30C automatic air eliminator with check valve and lockshield valve screwed BSP.

Spare parts

The spare parts available are shown in solid outline. Parts drawn in broken line are not supplied as spares.

Available spares

Maintenance kit comprising: **2, 4, 5, 9, 10**
Valve cone, float, cap 'O' ring, check valve ball and check valve circlip

Important note

If you have earlier versions of the AE30 designated AE30 and AE30CV which operate over the range 0 - 30 bar then the spares set for the AE30, A, B and C can be used (but this will not convert it to operate over the range 0 - 8 bar).

However if you have the AE30H and AE30HCV which operate over the range 3 - 8 bar then the earlier spares set should be used.



How to order spares

Always order spares by using the description given in the column headed 'Available spares' and state the size and type of automatic air eliminator/air vent.

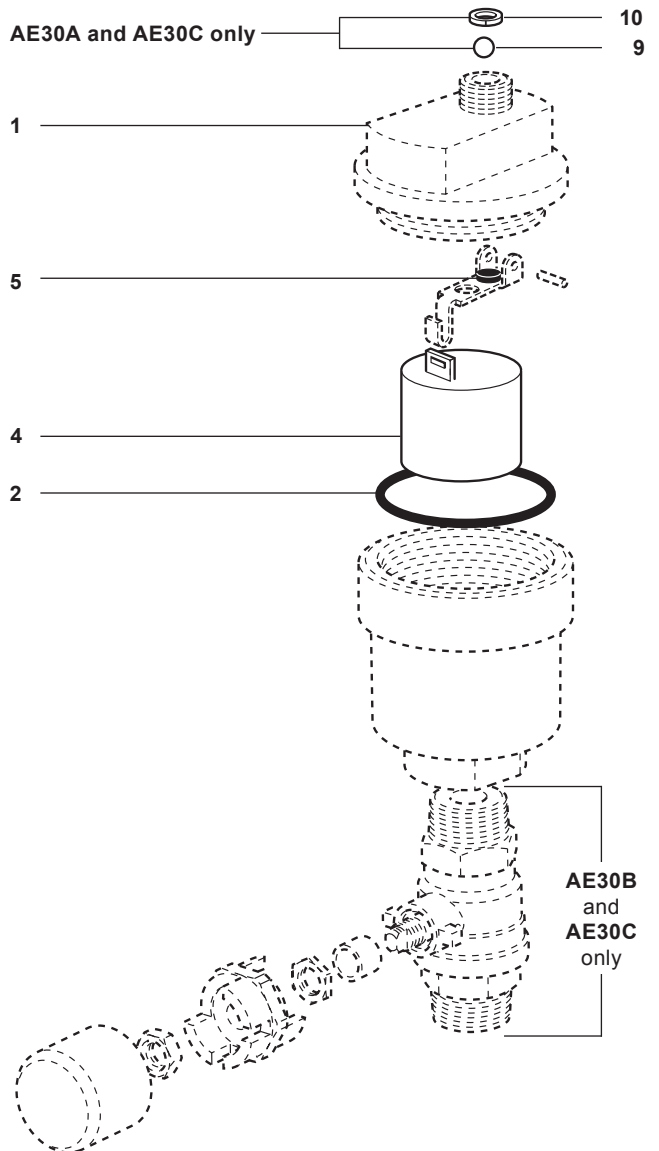
Example: 1 - Maintenance kit for a Spirax Sarco ½" AE30A automatic air eliminator with check valve.



Recommended tightening torques

Item		or mm		N m
1	30			10 - 12
8	Cheesehead		M4 x 6	