



AirMist pneumatic atomizing nozzles

Wide flat fan, pressurized liquid supply, internal mix

Series 166.4



Version with magnetic valve.
Particularly fine flat fan
atomization with air or gas.
Siphon principle.
Internal mixing of fluids.

Applications:

- Web dampening
- Cooling
- Humidification of goods

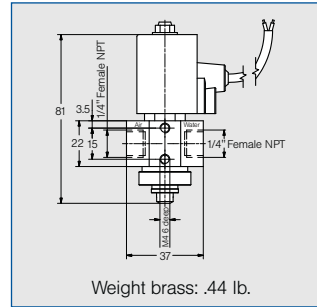

Series 166.4

Technical data:

- Pressure: 0-90 PSI
- Voltage: 24 VDC
- Power: 8W
- Frequency: 500 per min.
- Enclosure rating: IP67
- Temperature: 50°-122°F
- Cable length: 40"
- Seal: EPDM

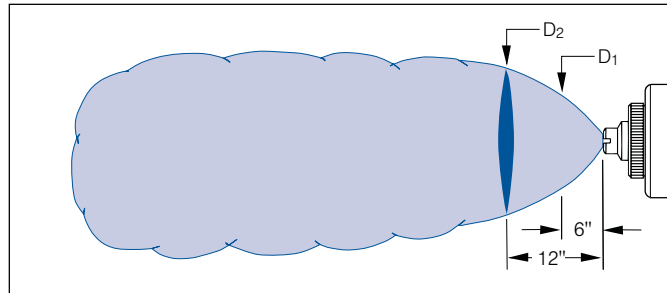

Additional flow rate data available upon request.

Pneumatic atomizing

Spray angle	Ordering no.	Maximum Free Passage (in.)	Liquid Flow GPH (Gallons Per Hour) at Indicated Liquid Pressure Air Flow SCFM (Standard Cubic Feet Per Minute)												Spray Dimensions			
			10 psi			20 psi			40 psi			60 psi			Air psi	Liq. psi	D1 (in.)	D2 (in.)
			Air psi	GPH	SCFM	Air psi	GPH	SCFM	Air psi	GPH	SCFM	Air psi	GPH	SCFM				
45°	166. 414. 16. B2	.028	15	2.0	.77	20	3.8	.88	32	5.9	1.2	44	6.6	1.5	20	10	3	5
			17	1.6	.88	26	3.1	1.1	44	4.7	1.5	55	5.5	1.8	35	20	4	6
			20	1.1	1.0	32	2.4	1.3	55	3.5	2.0	67	4.5	2.2	46	30	4	6
			23	.71	1.1	38	1.6	1.5	67	2.3	2.4	78	3.4	2.7	55	40	5	7
			26	.34	1.2	46	.55	1.9	84	.66	3.1	84	2.9	2.9				
	166. 462. 16. B2	.059	17	5.0	1.5	29	5.8	1.2	44	16	2.4	55	20	2.7	17	10	5	6
			29	2.5	2.4	41	3.8	1.6	49	14	2.8	61	17	3.2	35	20	5	7
			35	1.9	2.8	52	2.3	2.1	55	12	3.4	67	15	3.8	46	30	5	7
			41	1.5	3.2	64	1.6	2.5	67	8.8	4.4	73	14	4.2	55	40	6	8
			52	.95	3.9	75	.85	2.9	78	6.7	5.2	78	12	4.8				
60°	166. 425. 16. B2	.020	12	1.7	.71	20	2.5	1.0	35	3.5	1.5	35	4.3	1.5	17	10	6	8
			17	1.5	.94	32	2.1	1.4	44	3.2	1.8	41	4.1	1.7	32	20	6	10
			23	1.2	1.1	38	1.9	1.6	49	3.1	2.0	46	4.0	1.9	44	30	7	10
			29	1.1	1.4	44	1.7	1.8	55	2.9	2.2	52	3.8	2.1	49	40	8	13
			35	.85	1.5	55	1.3	2.2	67	2.6	2.5	58	3.7	2.2				
	166. 452. 16. B2	.059	15	5.0	2.3	26	8.2	3.1	46	13	4.5	55	19	4.8	15	10	5	7
			26	2.0	4.1	29	6.7	3.7	58	8.3	6.6	67	13	6.6	26	20	6	9
			32	1.1	4.9	32	5.3	4.2	70	4.7	8.5	78	8.9	8.7	38	30	6	10
			38	.26	5.8	38	3.3	5.2	81	2.8	10	84	7.3	9.7	52	40	7	11
			41	.03	6.1	41	2.7	5.7	87	2.3	11	87	6.4	10				
80°	166. 433. 16. B2	.016	15	3.1	1.2	26	4.8	1.6	44	8.2	2.2	55	9.9	2.6	20	10	6	8
			17	2.1	1.4	32	3.2	2.1	55	5.4	3.0	67	7.3	3.4	32	20	7	10
			20	1.4	1.6	38	2.0	2.5	67	3.3	3.9	78	5.1	4.2	44	30	8	12
			23	.98	1.9	44	1.2	2.9	78	1.7	4.7	87	3.8	4.9	55	60	12	19

For various configurations to mount your pneumatic air nozzles, see the Lances and Nozzle Headers section beginning on page 145.

