



# Flat fan nozzles

## Series 616 / 617



**Uniform, parabolic distribution of liquid. Increased non-clogging features, more jet power, less fog.**

Applications:

Cleaning installations, rain curtains, gravel washing, spray pipes, foam spraying, roll cooling, cooling of rolled stock.

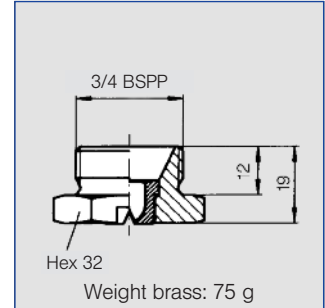

Spray angle	Ordering no.				A ∅ [mm]	E ∅ [mm]	V̇ [l/min]							Spray width B at p = 2 bar	
	Type	Material-no.					p [bar]								
		16 1.4305/303 SS	17 1.4571/316 SS	30 Brass			0,5	1,0	2,0	[US gal./min] at 40 psi	3,0	5,0	10,0		
20°	616. 721	○	○	○	3,00	2,50	3,15	4,45	6,30	1,95	7,72	9,96	14,09	80	140
	616. 801	○	○	○	4,00	3,20	5,00	7,07	10,00	3,10	12,25	15,81	22,36	80	145
	616. 881	○	○	○	5,00	4,00	8,00	11,31	16,00	4,96	19,60	25,30	35,78	80	145
	616. 921	○	○	○	5,50	4,40	10,00	14,14	20,00	6,20	24,49	31,62	44,72	80	145
	616. 961	○	○	○	6,00	5,10	12,50	17,68	25,00	7,75	30,62	39,53	55,90	80	145
30°	616. 722	○	○	○	3,00	2,40	3,15	4,45	6,30	1,95	7,72	9,96	14,09	120	230
	616. 762	○	○	○	3,50	2,70	4,00	5,66	8,00	2,48	9,80	12,65	17,89	120	230
	616. 802	○	○	○	4,00	3,10	5,00	7,07	10,00	3,10	12,25	15,81	22,36	120	235
	616. 882	○	○	○	5,00	4,00	8,00	11,31	16,00	4,96	19,60	25,30	35,78	120	235
	616. 922	○	○	○	5,50	4,40	10,00	14,14	20,00	6,20	24,49	31,62	44,72	120	235
	616. 962	○	-	○	6,00	5,00	12,50	17,68	25,00	7,75	30,62	39,53	55,90	125	240
45°	616. 723	○	○	○	3,00	2,40	3,15	4,45	6,30	1,95	7,72	9,96	14,09	175	330
	616. 763	○	○	○	3,50	2,60	4,00	5,66	8,00	2,48	9,80	12,65	17,89	175	330
	616. 803	○	○	○	4,00	3,00	5,00	7,07	10,00	3,10	12,25	15,81	22,36	175	335
	616. 843	○	○	○	4,50	3,40	6,25	8,84	12,50	3,88	15,31	19,76	27,95	180	335
	616. 883	○	○	○	5,00	3,80	8,00	11,31	16,00	4,96	19,60	25,30	35,78	185	350
	616. 923	○	○	○	5,50	4,20	10,00	14,14	20,00	6,20	24,49	31,62	44,72	190	360
60°	616. 963	○	○	○	6,00	4,40	12,50	17,68	25,00	7,75	30,62	39,53	55,90	200	375
	616. 724	○	○	○	3,00	2,10	3,15	4,45	6,30	1,95	7,72	9,96	14,09	295	575
	616. 764	○	○	○	3,50	2,30	4,00	5,66	8,00	2,48	9,80	12,65	17,89	300	580
	616. 804	○	○	○	4,00	2,60	5,00	7,07	10,00	3,10	12,25	15,81	22,36	300	580
	616. 844	○	○	○	4,50	3,00	6,25	8,84	12,50	3,88	15,31	19,76	27,95	300	580
	616. 884	○	○	○	5,00	3,40	8,00	11,31	16,00	4,96	19,60	25,30	35,78	300	580
	616. 924	○	○	○	5,50	4,10	10,00	14,14	20,00	6,20	24,49	31,62	44,72	300	580
	616. 964	○	○	○	6,00	4,20	12,50	17,68	25,00	7,75	30,62	39,53	55,90	300	580
90°	617. 044	○	-	○	8,00	5,50	20,00	28,28	40,00	12,41	48,99	63,25	89,44	300	580
	617. 124	-	-	○	10,00	7,40	31,50	44,55	63,00	19,54	77,16	99,61	140,87	300	580
	616. 726	○	○	○	3,00	1,70	3,15	4,45	6,30	1,95	7,72	9,96	14,09	540	1000
	616. 766	○	○	○	3,50	1,90	4,00	5,66	8,00	2,48	9,80	12,65	17,89	550	1010
	616. 806	○	○	○	4,00	2,40	5,00	7,07	10,00	3,10	12,25	15,81	22,36	550	1010
	616. 846	○	○	○	4,50	2,40	6,25	8,84	12,50	3,88	15,31	19,76	27,95	550	1020
616. 886	○	○	○	5,00	3,10	8,00	11,31	16,00	4,96	19,60	25,30	35,78	550	1020	
616. 926	○	○	○	5,50	3,60	10,00	14,14	20,00	6,20	24,49	31,62	44,72	555	1025	
616. 966	○	○	○	6,00	3,90	12,50	17,68	25,00	7,75	30,62	39,53	55,90	560	1030	

A = Equivalent bore diameter · E = narrowest free cross section  
Subject to technical modifications.

Continued on next page.

<b>Example for ordering:</b>	<b>Type</b>	<b>+</b>	<b>Material no.</b>	<b>=</b>	<b>Ordering no.</b>
	616. 721	+	16	=	616. 721. 16

Conversion formula for the above series:  $\dot{V}_2 = \dot{V}_1 * \sqrt{\frac{p_2}{p_1}}$





# Flat fan nozzles

## Series 616 / 617

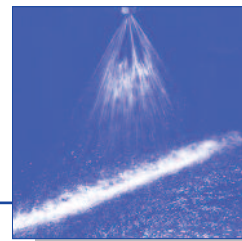

Spray angle	Ordering no.			A ∅ [mm]	E ∅ [mm]	V̇ [l/min]							Spray width B at p = 2 bar		
	Type	Material-no.				p [bar]							 H = 250 mm    H = 500 mm		
		16 1.4305/303 SS	17 1.4571/316 SS			30 Brass	0,5	1,0	2,0	[US gal/ min] at 40 psi	3,0	5,0			10,0
120°	616. 727	○	○	○	3,00	1,60	3,15	4,45	6,30	1,95	7,72	9,96	14,09	975	1755
	616. 767	○	○	○	3,50	1,70	4,00	5,66	8,00	2,48	9,80	12,65	17,89	970	1750
	616. 807	○	○	○	4,00	2,00	5,00	7,07	10,00	3,10	12,25	15,81	22,36	965	1740
	616. 887	○	○	○	5,00	2,60	8,00	11,31	16,00	4,96	19,60	25,30	35,78	955	1730
	616. 927	○	○	○	5,50	2,90	10,00	14,14	20,00	6,20	24,49	31,62	44,72	950	1720
	616. 967	-	-	○	6,00	3,20	12,50	17,68	25,00	7,75	30,62	39,53	55,90	950	1720
	617. 047	-	-	○	8,00	4,40	20,00	28,28	40,00	12,41	48,99	63,25	89,44	950	1720

A = Equivalent bore diameter · E = narrowest free cross section  
Subject to technical modifications.

The folded page at the end of the catalogue will give you a survey on the various assembly possibilities. For complete assembly accessories, please refer to „Accessories“.

<b>Example</b>	<b>Type</b>	<b>+</b>	<b>Material no.</b>	<b>=</b>	<b>Ordering no.</b>
<b>for ordering:</b>	<b>616. 727</b>	<b>+</b>	<b>16</b>	<b>=</b>	<b>616. 727. 16</b>