



Flat fan nozzles

Series 6F



Automatic nozzle alignment. High operation safety. Secure one-handed axial mounting. Variety of standard off-set angles. No-torque application prevents mechanical damage due to over-tightening of the nut.

Applications:

- Roll cooling

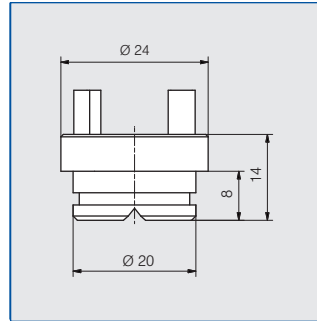

Spray Width (B) @ 45 psi

		H=10"	H=24"
6F4.721	6F4.921	3.9	7.9
6F4.941	6F5.201	4.5	8.3
6F4.722	6F4.962	5.9	11.8
6F4.982	6F5.202	6.3	12.2
6F4.723	6F4.963	8.7	17.3
6F4.983	6F5.203	9.9	19.3
6F4.724	6F4.964	13.0	24.8
6F4.984	6F5.204	13.4	25.2

Ordering no.				Material no.	Offset angle γ	Equivalent Orifice diam. (in.)	Flow Rate (Gallons Per Minute)									
Type							316 SS 17	Brass 30	10 psi	20 psi	liters per minute 2 bar	40 psi	60 psi	75 psi	100 psi	150 psi
Spray Angle																
20°	30°	45°	60°													
6F4. 721	6F4. 722	6F4. 723	6F4. 724	○	○	2.1-2.5	0.98	1.38	6.30	1.95	2.39	2.68	3.09	3.79		
6F4. 761	6F4. 762	6F4. 763	6F4. 764	○	○	2.3-2.8	1.24	1.76	8.00	2.48	3.04	3.40	3.92	4.81		
6F4. 801	6F4. 802	6F4. 803	6F4. 804	○	○	2.6-3.2	1.55	2.19	10.0	3.10	3.80	4.25	4.91	6.01		
6F4. 841	6F4. 842	6F4. 843	6F4. 844	○	○	3.0-3.6	1.94	2.74	12.5	3.88	4.75	5.31	6.13	7.51		
6F4. 881	6F4. 882	6F4. 883	6F4. 884	○	○	3.4-4.0	2.48	3.51	16.0	4.96	6.08	6.80	7.85	9.61		
6F4. 921	6F4. 922	6F4. 923	6F4. 924	○	○	4.1-4.4	3.10	4.39	20.0	6.21	7.60	8.50	9.81	12.0		
6F4. 941	6F4. 942	6F4. 943	6F4. 944	○	○	4.6-5.0	3.48	4.91	22.4	6.95	8.51	9.52	11.0	13.5		
6F4. 961	6F4. 962	6F4. 963	6F4. 964	○	○	4.2-5.3	3.88	5.49	25.0	7.76	9.50	10.6	12.3	15.0		
6F4. 981	6F4. 982	6F4. 983	6F4. 984	○	○	4.2-5.1	4.34	6.14	28.0	8.69	10.6	11.9	13.7	16.8		
6F5. 001	6F5. 002	6F5. 003	6F5. 004	○	○	4.8-5.6	4.89	6.91	31.5	9.77	12.0	13.4	15.5	18.9		
6F5. 011	6F5. 012	6F5. 013	6F5. 014	○	○	4.9-5.8	5.20	7.35	33.5	10.4	12.7	14.2	16.4	20.1		
6F5. 041	6F5. 042	6F5. 043	6F5. 044	○	○	5.5-6.6	6.21	8.78	40.0	12.4	15.2	17.0	19.6	24.0		
6F5. 061	6F5. 062	6F5. 063	6F5. 064	○	○	5.8-6.7	6.98	9.87	45.0	14.0	17.1	19.1	22.1	27.0		
6F5. 081	6F5. 082	6F5. 083	6F5. 084	○	○	6.6-7.4	7.76	11.0	50.0	15.5	19.0	21.2	24.5	30.0		
6F5. 121	6F5. 122	6F5. 123	6F5. 124	○	○	7.4-8.3	9.77	13.8	63.0	19.5	23.9	26.8	30.9	37.9		
6F5. 161	6F5. 162	6F5. 163	6F5. 164	○	○	8.3-8.4	12.4	17.6	80.0	24.8	30.4	34.0	39.2	48.1		
6F5. 181	6F5. 182	6F5. 183	6F5. 184	○	○	8.9-10.3	14.0	19.7	90.0	27.9	34.2	38.2	44.2	54.1		
6F5. 201	6F5. 202	6F5. 203	6F5. 204	○	○	9.6-10.5	15.5	21.9	100.0	31.0	38.0	42.5	49.1	60.1		

Example Type + Material no. + Offset angle = Ordering no.
for Ordering: 6F4. 721 + 17 + 15 = 6F4. 721. 17. 15

Ordering code for offset angle	
Offset angle γ	Ordering code
15°	15
20°	20
25°	25
30°	30
35°	35
40°	40
45°	45
50°	50
60°	60
70°	70

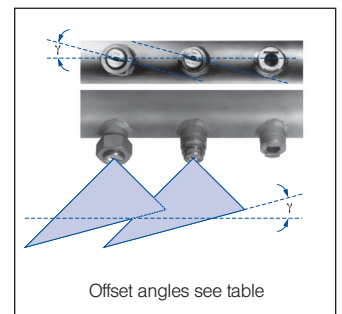

Accessories

Hex 32 3/4 BSPP
16 13
ø 20,1

Weight brass 60 g

Retaining nut: **065. 600. 11** (AISI 430 F)
065. 600. 16 (303 SS)
065. 600. 17 (316 SS)
065. 600. 30 (brass)

Ø 28
Ø 14
L₁
3/4 BSPP

Weight 82 g

Welding nipple: **06F. 410. 17. xx** (316 SS)
06F. 411. 17. xx (316 SS)

L₂ = L₁ + 14 mm

Removal tool
Ordering no. **06S. 491. 1C**

