

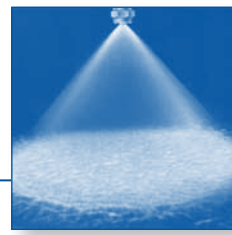

Full cone tips Axial-flow Series 468



Excellent uniform full cone distribution and thorough atomization. Spray angles are consistent over the full capacity range.

Applications:

- Washing and cleaning
- Mist eliminator washing
- Chemical reactors
- Surface spraying

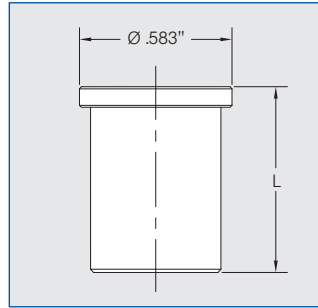

Dimensions (in.)		
Capacity	Length (L)	Wt. brass (lb.)
468.36X-468.60X	.71	.04
468.64X-468.84X	.97	.04

Spray angle	Ordering no.				Orifice diam. (in.)	Free passage (in.)	Flow Rate (Gallons Per Minute)										L (in.)	Spray Diam. D (in.) @ 30 psi	
	Type	Material no.					liters per minute											H=8"	H=20"
		316 SS 17 ¹⁾	Brass 30	PVDF 5E			10 psi	20 psi	2.0 bar	30 psi	40 psi	60 psi	80 psi	100 psi	150 psi				
60°	468. 604	-	○	-	.081	.055	.54	.72	3.2	.84	.95	1.1	1.2	1.4	1.6	.71	9	22	
	468. 644	-	○	○	.095	.075	.69	.91	4.0	1.1	1.2	1.4	1.6	1.7	2.0	.97	9	22	
	468. 684	-	○	○	.102	.079	.86	1.1	5.0	1.3	1.5	1.8	2.0	2.2	2.5	.97	9	22	
	468. 724	○	○	-	.114	.079	1.1	1.4	6.3	1.7	1.9	2.2	2.5	2.7	3.2	.97	9	22	
90°	468. 526	○	○	○	.065	.051	.35	.46	2.0	.54	.60	.71	.79	.87	1.0	.71	15	34	
	468. 846	-	○	-	.160	.126	2.2	2.9	12.5	3.4	3.8	4.4	5.0	5.4	6.4	.97	15	34	
120°	468. 368	-	○	-	.037	.028	.11	.14	.60	.17	.19	.22	.25	.27	.32	.71	27	61	
	468. 408	○	○	-	.047	.033	.17	.23	1.0	.27	.30	.35	.40	.43	.51	.71	27	61	
	468. 488	○	○	-	.059	.039	.28	.36	1.6	.43	.48	.57	.63	.69	.82	.71	27	61	
	468. 528	○	○	-	.065	.047	.35	.46	2.0	.54	.60	.71	.79	.87	1.0	.71	27	61	

Bases and Caps for Mounting

Inlet NPT Male	Outlet Male	Part No.	Standard Materials: 17 316 SS 30 Brass
1/4" 3/8"	11/16 x 16 11/16 x 16	065. 215. XX. 10 065. 211. XX. 10	
1/4" 3/8"	3/8 BSPP 3/8 BSPP	065. 215. XX. 11 065. 215. XX. 12	
Caps			Other materials available. See Accessories beginning on page 123.
To fit 11/16x16 To fit 3/8 BSPP		069. 000. XX. 00 065. 200. XX. 00	

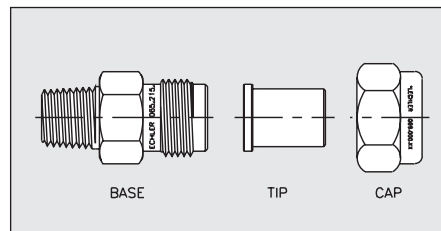

Example Type + Material no. = Ordering no.
for ordering: 468. 526 + 17 = 468. 526. 17

1) We reserve the right to deliver material 316 SS or 316L SS, if we show the material code 17.

A listing of alternatives for various assembly possibilities is shown in the Accessories section beginning on page 123.