

Temperature Measurement

Transmitters for mounting in sensor head

SITRANS TH200 two-wire system, universal

Overview



Ultra flexible - with the universal SITRANS TH200 transmitter

- Two-wire devices for 4 to 20 mA
- Mounting in the connection head of the temperature sensor
- Universal input for virtually any type of temperature sensor
- Configurable over PC

Benefits

- Compact design
- Flexible mounting and center hole allow you to select your preferred type of installation
- Electrically isolated
- Test sockets for multimeters
- Diagnostics LED (green/red)
- Sensor monitoring open circuits and short-circuits
- Self-monitoring
- Configuration status stored in EEPROM
- SIL2 (with Order code C20), SIL2/3 (with C23)
- Expanded diagnostic functions, such as slave pointer, operating hours counter, etc.
- Special characteristic
- Electromagnetic compatibility to EN 61326 and NE21

Application

SITRANS TH200 transmitters can be used in all industrial sectors. Due to their compact size they can be installed in the connection head type B (DIN 43729) or larger. The following sensors/signal sources can be connected over their universal input module:

- Resistance thermometers (2, 3 or 4-wire system)
- Thermocouples
- Resistance-based sensors and DC voltage sources

The output signal is a direct current from 4 to 20 mA in accordance with the sensor characteristic.

Transmitters of the "intrinsically safe" type of protection can be installed within potentially explosive atmospheres. The devices comply with the Directive 2014/34/EU (ATEX), as well as FM and CSA regulations.

Function

The SITRANS TH200 is configured over a PC. A USB or RS 232 modem is linked to the output terminals for this purpose. The configuration data can now be edited using the SIPROM T software tool. The configuration data are then permanently stored in the non-volatile memory (EEPROM).

Once the sensors and power supply have been correctly connected, the transmitter outputs a temperature-linear output signal and the diagnostics LED displays a green light. In the case of a sensor short-circuit, the LED flashes red, an internal device fault is indicated by a steady red light.

The test socket can be used to connect an ammeter at any time for monitoring purposes and plausibility checks. The output current can be read without any interruption, or even without opening the current loop.

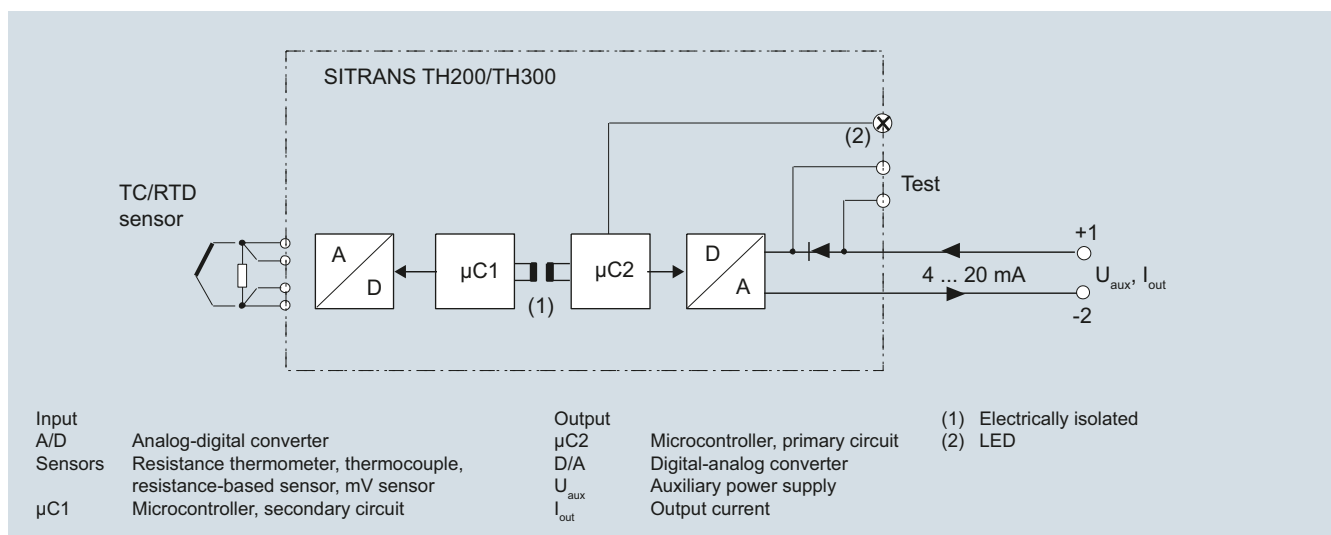

SITRANS TH200 function diagram

Technical specifications

| | | | |
|--|---|--|--|
| Input | | Response time | |
| <u>Resistance thermometer</u> | | ≤ 250 ms for 1 sensor with open-circuit monitoring | |
| Measured variable | Temperature | Open-circuit monitoring | Always active (cannot be disabled) |
| Sensor type | | Short-circuit monitoring | can be switched on/off (default value: OFF) |
| • to IEC 60751 | Pt25 ... Pt1000 | Measuring range | parameterizable max. 0 ... 2200 Ω (see table "Digital measuring errors") |
| • To JIS C 1604; $\alpha = 0.00392 \text{ K}^{-1}$ | Pt25 ... Pt1000 | Min. measured span | 5 Ω ... 25 Ω (see Table "Digital measuring errors") |
| • to IEC 60751 | Ni25 ... Ni1000 | Characteristic curve | Resistance-linear or special characteristic |
| • Special type | over special characteristic (max. 30 points) | <u>Thermocouples</u> | |
| Sensor factor | 0.25 ... 10 (adaptation of the basic type, e.g. Pt100 to version Pt25 ... 1000) | Measured variable | Temperature |
| Units | °C or °F | Sensor type (thermocouples) | |
| Connection | | • Type B | Pt30Rh-Pt6Rh to DIN IEC 584 |
| • Standard connection | 1 resistance thermometer (RTD) in 2-wire, 3-wire or 4-wire system | • Type C | W5 %-Re acc. to ASTM 988 |
| • Generation of average value | 2 identical resistance thermometers in 2-wire system for generation of average temperature | • Type D | W3 %-Re acc. to ASTM 988 |
| • Generation of difference | 2 identical resistance thermometers (RTD) in 2-wire system (RTD 1 – RTD 2 or RTD 2 – RTD 1) | • Type E | NiCr-CuNi to DIN IEC 584 |
| Interface | | • Type J | Fe-CuNi to DIN IEC 584 |
| • Two-wire system | Parameterizable line resistance ≤ 100 Ω (loop resistance) | • Type K | NiCr-Ni to DIN IEC 584 |
| • Three-wire system | No balancing required | • Type L | Fe-CuNi to DIN 43710 |
| • Four-wire system | No balancing required | • Type N | NiCrSi-NiSi to DIN IEC 584 |
| Sensor current | ≤ 0.45 mA | • Type R | Pt13Rh-Pt to DIN IEC 584 |
| Response time | ≤ 250 ms for 1 sensor with open-circuit monitoring | • Type S | Pt10Rh-Pt to DIN IEC 584 |
| Open-circuit monitoring | Always active (cannot be disabled) | • Type T | Cu-CuNi to DIN IEC 584 |
| Short-circuit monitoring | can be switched on/off (default value: ON) | • Type U | Cu-CuNi to DIN 43710 |
| Measuring range | parameterizable (see table "Digital measuring errors") | Units | °C or °F |
| Min. measured span | 10 °C (18 °F) | Connection | |
| Characteristic curve | Temperature-linear or special characteristic | • Standard connection | 1 thermocouple (TC) |
| <u>Resistance-based sensors</u> | | • Generation of average value | 2 thermocouples (TC) |
| Measured variable | Actual resistance | • Generation of difference | 2 thermocouples (TC) (TC1 – TC2 or TC2 – TC1) |
| Sensor type | Resistance-based, potentiometers | Response time | ≤ 250 ms for 1 sensor with open-circuit monitoring |
| Units | Ω | Open-circuit monitoring | Can be switched off |
| Connection | | Cold junction compensation | |
| • Normal connection | 1 resistance-based sensor (R) in 2-wire, 3-wire or 4-wire system | • Internal | With integrated Pt100 resistance thermometer |
| • Generation of average value | 2 resistance-based sensors in 2-wire system for generation of average value | • External | With external Pt100 IEC 60571 (2-wire or 3-wire connection) |
| • Generation of difference | 2 resistance thermometers in 2-wire system (R1 – R2 or R2 – R1) | • External fixed | Cold junction temperature can be set as fixed value |
| Interface | | Measuring range | Parameterizable (see table "Digital measuring errors") |
| • Two-wire system | Parameterizable line resistance ≤ 100 Ω (loop resistance) | Min. measured span | Min. 40 ... 100 °C (72 ... 180 °F) (see table "Digital measuring errors") |
| • Three-wire system | No balancing required | Characteristic curve | Temperature-linear or special characteristic |
| • Four-wire system | No balancing required | <u>mV sensor</u> | |
| Sensor current | ≤ 0.45 mA | Measured variable | DC voltage |
| | | Sensor type | DC voltage source (DC voltage source possible over an externally connected resistor) |
| | | Units | mV |
| | | Response time | ≤ 250 ms for 1 sensor with open-circuit monitoring |
| | | Open-circuit monitoring | Can be switched off |
| | | Measuring range | -10 ... +70 mV-100 ... +1100 mV |

Temperature Measurement

Transmitters for mounting in sensor head

SITRANS TH200 two-wire system, universal

| | |
|---|---|
| Min. measured span | 2 mV or 20 mV |
| Overload capability of the input | -1.5 ... +3.5 V DC |
| Input resistance | ≥ 1 MΩ |
| Characteristic curve | Voltage-linear or special characteristic |
| Output | |
| Output signal | 4 ... 20 mA, 2-wire |
| Auxiliary power | 11 ... 35 V DC ((to 30 V for Ex ia and ib; to 32 V for Ex nA / nL / ic) |
| Max. load | ($U_{aux} - 11$ V)/0.023 A |
| Overrange | 3.6 ... 23 mA, infinitely adjustable (default range: 3.80 mA ... 20.5 mA) |
| Error signal (e.g. following sensor fault) (conforming to NE43) | 3.6 ... 23 mA, infinitely adjustable (default value: 22.8 mA) |
| Sample cycle | 0.25 s nominal |
| Damping | Software filter 1st order 0 ... 30 s (parameterizable) |
| Protection | Against reversed polarity |
| Electrically isolated | Input against output (1 kV _{eff}) |
| Measuring accuracy | |
| Digital measuring errors | See table "Digital measuring errors" |
| Reference conditions | |
| • Auxiliary power | 24 V ± 1 % |
| • Load | 500 Ω |
| • Ambient temperature | 23 °C |
| • Warming-up time | > 5 min |
| Error in the analog output (digital/analog converter) | < 0.025 % of span |
| Error due to internal cold junction | < 0.5 °C (0.9 °F) |
| Influence of ambient temperature | |
| • Analog measuring error | 0.02 % of span/10°C (18 °F) |
| • Digital measuring errors | |
| - with resistance thermometers | 0.06 °C (0.11 °F)/10°C (18 °F) |
| - with thermocouples | 0.6 °C (1.1 °F)/10°C (18 °F) |
| Auxiliary power effect | < 0.001 % of span/V |
| Effect of load impedance | < 0.002 % of span/100 Ω |
| Long-term drift | |
| • In the first month | < 0.02 % of span |
| • After one year | < 0.2 % of span |
| • After 5 years | < 0.3 % of span |
| Conditions of use | |
| <u>Ambient conditions</u> | |
| Ambient temperature range | -40 ... +85 °C (-40 ... +185 °F) |
| Storage temperature range | -40 ... +85 °C (-40 ... +185 °F) |
| Relative humidity | < 98 %, with condensation |
| Electromagnetic compatibility | acc. to EN 61326 and NE21 |
| Construction | |
| Material | Molded plastic |
| Weight | 50 g (0.11 lb) |
| Dimensions | See "Dimensional drawings" |
| Cross-section of cables | Max. 2.5 mm ² (AWG 13) |
| Degree of protection to IEC 60529 | |
| • Enclosure | IP40 |
| • Terminals | IP00 |

Certificates and approvals

Explosion protection ATEX

EC type test certificate

• "Intrinsic safety" type of protection

• "Operating equipment that is non-ignitable and has limited energy" type of protection

Explosion protection: FM for USA

• FM approval

• Degree of protection

Explosion protection to FM for Canada (cFM_{US})

• FM approval

• Degree of protection

Other certificates

Software requirements for SIPROM T

PC operating system

Factory setting:

- Pt100 (IEC 751) with 3-wire circuit
- Measuring range: 0 ... 100 °C (32 ... 212 °F)
- Fault current: 22.8 mA
- Sensor offset: 0 °C (0 °F)
- Damping 0.0 s

PTB 05 ATEX 2040X

II 1 G Ex ia IIC T6/T4
II 2 (1) G Ex ia/ib IIC T6/T4
II 3(1) G Ex ia/ic IIC T6/T4
II 1D Ex iaD 20 T115 °C

II 3 G Ex nL IIC T6/T4
II 3 G Ex nA IIC T6/T4

FM 3024169

IS / CI I, II, III / Div 1 / GP ABC-DEFG T6, T5, T4
CI I / ZN 0 / AEx ia IIC T6, T5, T4
NI / CI I / Div 2 / GP ABCDFG T6, T5, T4
NI / CI I / ZN 2 / IIC T6, T5, T4

FM 3024169C

IS / CI I, II, III / Div 1 / GP ABCDEFG T6, T5, T4
NI / CI I / DIV 2 / GP ABCD T6, T5, T4
NIFW / CI I, II, III / DIV 2 / GP ABCDFG T6, T5, T4
DIP / CI II, III / Div 2 / GP FG T6, T5, T4
CI I / ZN 0 / Ex ia IIC T6, T5, T4
CI I / ZN 2 / Ex nA nL IIC T6, T5, T4

EAC Ex(GOST), NEPSI, IEC, EXPOLABS

Windows ME, 2000, XP, Win 7 and Win 8; can also be used in connection with RS 232 modem under Windows 95, 98 and 98SE

Temperature Measurement

Transmitters for mounting in sensor head

SITRANS TH200 two-wire system, universal

Digital measuring errors

Resistance thermometer

| Input | Measuring range °C / (°F) | Min. mea- sured span | | Digital accuracy | |
|------------------------|-----------------------------------|-------------------------|------|---------------------|--------|
| | | °C | (°F) | °C | (°F) |
| to IEC 60751 | | | | | |
| Pt25 | -200 ... +850 (-328 ... +1562) | 10 | (18) | 0.3 | (0.54) |
| Pt50 | -200 ... +850 (-328 ... +1562) | 10 | (18) | 0.15 | (0.27) |
| Pt100 ... Pt200 | -200 ... +850 (-328 ... +1562) | 10 | (18) | 0.1 | (0.18) |
| Pt500 | -200 ... +850 (-328 ... +1562) | 10 | (18) | 0.15 | (0.27) |
| Pt1000 | -200 ... +350 (-328 ... +662) | 10 | (18) | 0.15 | (0.27) |
| to JIS C1604-81 | | | | | |
| Pt25 | -200 ... +649 (-328 ... +1200) | 10 | (18) | 0.3 | (0.54) |
| Pt50 | -200 ... +649 (-328 ... +1200) | 10 | (18) | 0.15 | (0.27) |
| Pt100 ... Pt200 | -200 ... +649 (-328 ... +1200) | 10 | (18) | 0.1 | (0.18) |
| Pt500 | -200 ... +649 (-328 ... +1200) | 10 | (18) | 0.15 | (0.27) |
| Pt1000 | -200 ... +350 (-328 ... +662) | 10 | (18) | 0.15 | (0.27) |
| Ni 25 ... Ni1000 | -60 ... +250 (-76 ... +482) | 10 | (18) | 0.1 | (0.18) |

Resistance-based sensors

| Input | Measuring range Ω | Min. mea- sured span Ω | Digital accuracy Ω |
|------------|----------------------|------------------------------|--------------------------|
| | | | |
| Resistance | 0 ... 390 | 5 | 0.05 |
| Resistance | 0 ... 2200 | 25 | 0.25 |

Thermocouples

| Input | Measuring range °C/(°F) | Min. mea- sured span | | Digital accu- racy (°F) |
|-------------|------------------------------------|-------------------------|-------|-------------------------------------|
| | | °C | (°F) | |
| Type B | 100 ... 1820 (212 ... 3308) | 100 | (180) | 2 ¹⁾ (3.6) ¹⁾ |
| Type C (W5) | 0 ... 2300 (32 ... 4172) | 100 | (180) | 2 (3.6) |
| Type D (W3) | 0 ... 2300 (32 ... 4172) | 100 | (180) | 1 ²⁾ (1.8) ²⁾ |
| Type E | -200 ... +1000 (-328 ... +1832) | 50 | (90) | 1 (1.8) |
| Type J | -210 ... +1200 (-346 ... +2192) | 50 | (90) | 1 (1.8) |
| Type K | -230 ... +1370 (-382 ... +2498) | 50 | (90) | 1 (1.8) |
| Type L | -200 ... +900 (-328 ... +1652) | 50 | (90) | 1 (1.8) |
| Type N | -200 ... +1300 (-328 ... +2372) | 50 | (90) | 1 (1.8) |
| Type R | -50 ... +1760 (-58 ... +3200) | 100 | (180) | 2 (3.6) |
| Type S | -50 ... +1760 (-58 ... +3200) | 100 | (180) | 2 (3.6) |
| Type T | -200 ... +400 (-328 ... +752) | 40 | (72) | 1 (1.8) |
| Type U | -200 ... +600 (-328 ... +1112) | 50 | (90) | 2 (3.6) |

¹⁾ The digital accuracy in the range 100 to 300 °C (212 to 572 °F) is 3 °C (5.4 °F).

²⁾ The digital accuracy in the range 1750 to 2300 °C (3182 to 4172 °F) is 2 °C (3.6 °F).

mV sensor

| Input | Measuring range mV | Min. measured span mV | Digital accuracy μV |
|-----------|--------------------------|-----------------------------|---------------------------|
| | | | |
| mV sensor | -10 ... +70 | 2 | 40 |
| mV sensor | -100 ... +1100 | 20 | 400 |

The digital accuracy is the accuracy after the analog/digital conversion including linearization and calculation of the measured value.

An additional error is generated in the output current 4 to 20 mA as a result of the digital/analog conversion of 0.025 % of the set span (digital-analog error).

The total error under reference conditions at the analog output is the sum from the digital error and the digital-analog error (poss. with the addition of cold junction errors in the case of thermocouple measurements).

Temperature Measurement

Transmitters for mounting in sensor head

SITRANS TH200 two-wire system, universal

| Selection and Ordering data | Article No. |
|---|---------------------------|
| Temperature transmitter SITRANS TH200 for installation in connection head, type B (DIN 43729), two-wire system, 4 ... 20 mA, programmable, with electrical isolation | |
| <ul style="list-style-type: none"> • Without explosion protection ▶ ◆ 7NG3211-1NN00 • With explosion protection <ul style="list-style-type: none"> - to ATEX ▶ ◆ 7NG3211-1AN00 - to FM (cFM_{US}) ▶ ◆ 7NG3211-1BN00 | |
| Further designs | Order code |
| Add "-Z" to Article No. and specify Order code(s) | |
| With test protocol (5 measuring points) | C11 |
| Functional safety SIL2 | C20 |
| Functional safety SIL2/3 | C23 |
| Customer-specific programming | |
| Add "-Z" to Article No. and specify Order code(s) | |
| Measuring range to be set Specify in plain text (max. 5 digits): Y01: ... to ... °C, °F | Y01¹⁾ |
| Measuring point no. (TAG), max. 8 characters | Y17²⁾ |
| Measuring point descriptor, max. 16 characters | Y23²⁾ |
| Measuring point message, max. 32 characters | Y24²⁾ |
| Pt100 (IEC) 2-wire, R _L = 0 Ω | U02³⁾ |
| Pt100 (IEC) 3-wire | U03³⁾ |
| Pt100 (IEC) 4-wire | U04³⁾ |
| Thermocouple type B | U20³⁾⁴⁾ |
| Thermocouple type C (W5) | U21³⁾⁴⁾ |
| Thermocouple type D (W3) | U22³⁾⁴⁾ |
| Thermocouple type E | U23³⁾⁴⁾ |
| Thermocouple type J | U24³⁾⁴⁾ |
| Thermocouple type K | U25³⁾⁴⁾ |
| Thermocouple type L | U26³⁾⁴⁾ |
| Thermocouple type N | U27³⁾⁴⁾ |
| Thermocouple type R | U28³⁾⁴⁾ |
| Thermocouple type S | U29³⁾⁴⁾ |
| Thermocouple type T | U30³⁾⁴⁾ |
| Thermocouple type U | U31³⁾⁴⁾ |
| With TC: CJC external (Pt100, 3-wire) | U41 |
| With TC: CJC external with fixed value, specify in plain text | Y50 |
| Special differing customer-specific programming, specify in plain text | Y09⁵⁾ |
| Fail-safe value 3.6 mA (instead of 22,8 mA) | U36²⁾ |
| Cable extension Transmitter with installed cable extension 200 mm (7.81 inch), for Pt100 in four-wire system | W01 |

| Accessories | Article No. |
|--|--------------------|
| Modem for SITRANS TH100, TH200, TR200 and TF with TH200 incl. SIPROM T parameterization software ▶ With USB connection | 7NG3092-8KU |
| MiniDVD for temperature measuring instruments ▶ With documentation in German, English, French, Spanish, Italian, Portuguese and SIPROM T parameterization software | A5E00364512 |
| DIN rail adapters for head transmitters ▶ (Quantity delivered: 5 units) | 7NG3092-8KA |
| Connecting cable 4-wire, 150 mm, for sensor connections when using head transmitters in the high hinged cover (set with 5 units) | 7NG3092-8KC |

▶ Available ex stock.

◆ We can offer shorter delivery times for configurations designated with the Quick Ship Symbol ◆. For details see page 9/5 in the appendix.

- 1) For customer-specific programming for RTD and TC, the start value and the end value of the required measuring span must be specified here.
- 2) For this selection, Y01 or Y09 must also be selected.
- 3) For this selection, Y01 must also be selected.
- 4) Internal cold junction compensation is selected as the default for TC.
- 5) For customer-specific programming, for example mV and ohm, the start value and the end value of the required measuring span and the unit must be entered here.

Supply units see Chapter "Supplementary Components".

Ordering example 1:

7NG3211-1NN00-Z Y01+Y17+U03
 Y01: -10 ... +100 °C
 Y17: TICA123

Ordering example 2:

7NG3211-1NN00-Z Y01+Y23+U25
 Y01: -10 ... +100 °C
 Y23: TICA1234HEAT

Factory setting:

- Pt100 (IEC 751) with 3-wire circuit
- Measuring range: 0 ... 100 °C (32 ... 212 °F)
- Fault current: 22.8 mA
- Sensor offset: 0 °C (0 °F)
- Damping 0.0 s

Temperature Measurement

Transmitters for mounting in sensor head

SITRANS TH200 two-wire system, universal

Dimensional drawings

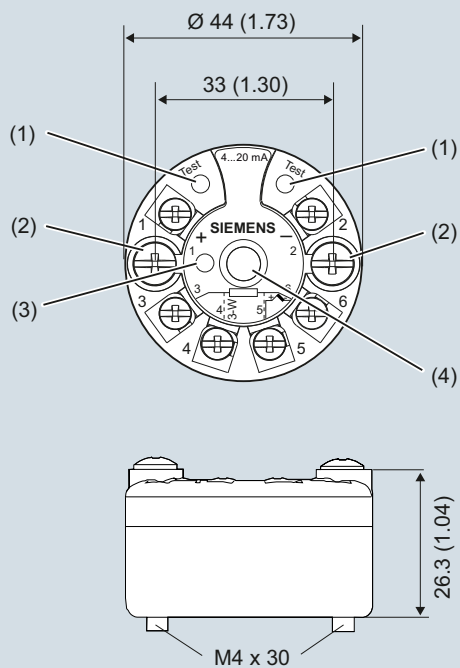

- | | | |
|-----------|----------|--|
| 1(+) | and 2(-) | Auxiliary power supply U_{aux} , output current I_{out} |
| 3, 4, 5 | and 6 | Pt100 sensor (for connections, see Sensor connection assignment) |
| Test (+), | Test (-) | Measurement of the output current with a multimeter |
| (1) | | Test terminal |
| (2) | | Mounting screw M4x30 |
| (3) | | LED for operation indication |
| (4) | | Internal diameter of center hole 6.3 (0.25) |

SITRANS TH200, dimensions and pin assignment, dimensions in mm (inch)

Mounting on DIN rail

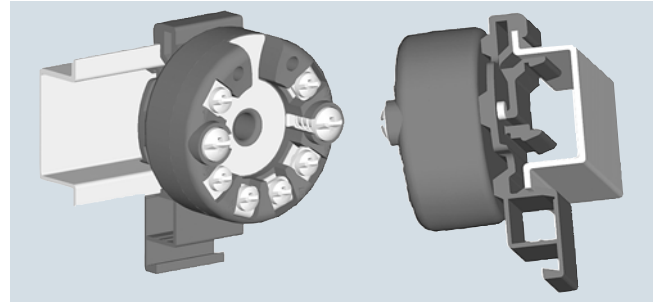

SITRANS TH200, mounting of transmitter on DIN rail

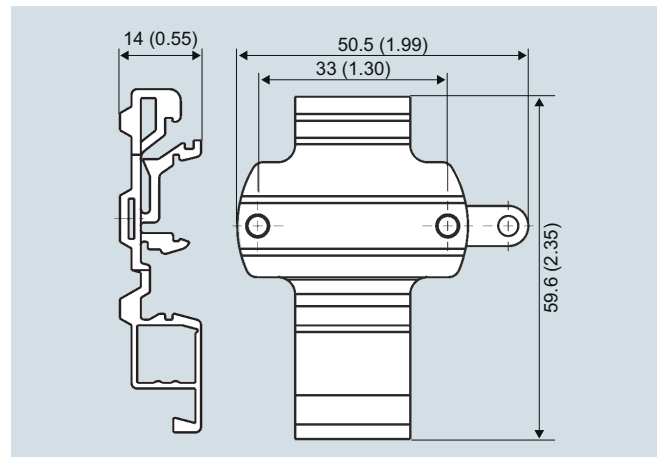

DIN rail adapter, dimensions in mm (inch)

Temperature Measurement

Transmitters for mounting in sensor head

SITRANS TH200 two-wire system, universal

Schematics

2

Resistance thermometer

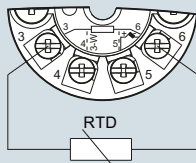

Two-wire system ¹⁾

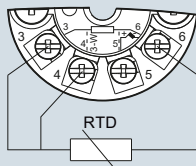

Three-wire system

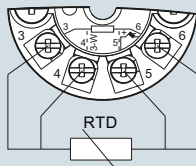

Four-wire system

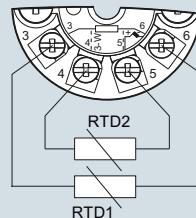

Generation of average value / difference ¹⁾

¹⁾ Programmable line resistance for the purpose of correction.

Resistance

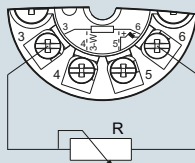

Two-wire system ¹⁾

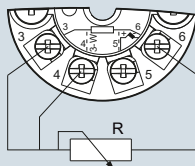

Three-wire system

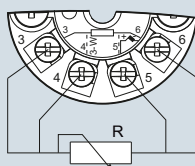

Four-wire system

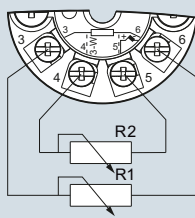

Generation of average value / difference ¹⁾

Thermocouple

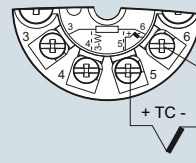

Cold junction compensation
Internal/fixed value

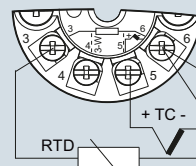

Cold junction compensation with
external Pt100 in two-wire system ¹⁾

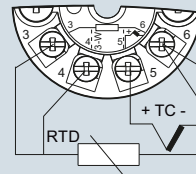

Cold junction compensation with
external Pt100 in three-wire system

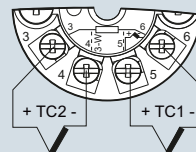

Generation of average value / difference
with internal cold junction compensation

Voltage measurement

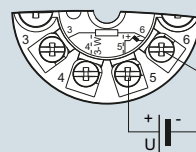

Current measurement

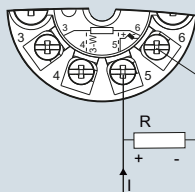

Connection of auxiliary power supply (U_{aux})

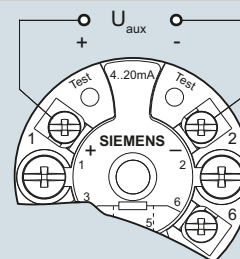

SITRANS TH200, sensor connection assignment