



## FEATURES



- Full port, 1/4"~4" (DN8~DN100)
- W.P. : 1000 WOG (PN63)
- W.T. : -20°C~200°C (-4°F~392°F)
- Investment casting
- Blow-out proof stem
- Locking device
- ISO 5211 Mounting pad
- TA-Luft approved (option)
- Length conform to DIN 3202/4-M3-2012NM-M3 (option)

- Butt weld ends conform to ANSI B16.25 & DIN 3239 part1

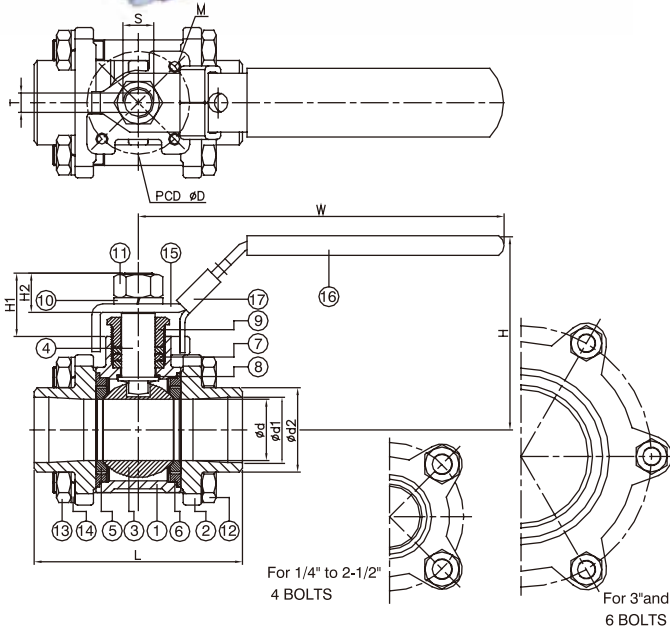

ITEM	PARTS	MATERIAL
1	BODY	ASTM A351-CF8M
2	CAP	ASTM A216-WCB
3	BALL	ASTM A351-CF8M
4	STEM	ASTM A276-316
5	SEAT	PTFE / RTFE
6	SEAL	
7	PACKING	PTFE
8	THRUST WASHER	
9	GLAND NUT	
10	SPRING WASHER	
11	STEM NUT	
12	BOLT	AISI 304
13	NUT	AISI 304
14	SPRING WASHER	
15	HANDLE	STAINLESS STEEL
16	HANDLE SLEEVE	PVC
17	LOCKING DEVICE	STAINLESS STEEL

DN	d	d1	d2	D	M	L	H	W	S	T	H1	H2	ISO 5211	Torque (N-M)	Weight (kg)
8	11.6	14.5	-	36	M5	65	58.5	100	3/8"-24UNF	5	19.3	13.5	F03	7.5	0.4
10	12.5	18	-	36	M5	65	58.5	100	3/8"-24UNF	5	19.3	13.5	F03	7.5	0.4
15	15	22	15.8	36	M5	65	62	100	3/8"-24UNF	5	19.4	13.5	F03	7.5	0.5
20	20	27.5	20.9	36	M5	75	62	125	7/16"-20UNF	6.5	22.4	16	F03	7.5	0.7
25	25	34	26.6	42	M5	85	77	149	7/16"-20UNF	8	25.6	16.2	F04	12.5	1
32	32	43	35.1	42	M5	101	82	149	7/16"-20UNF	8	25.6	16.2	F04	15	1.7
40	38	49	40.9	50	M6	112	100	190	1/2"-20UNF	10	29.7	20	F05	20	2.4
50	50	61	52.5	50	M6	130	108	190	1/2"-20UNF	10	29.7	20	F05	25	3.5
65	63	74	62.7	70	M8	162	137	250	3/4"-10UNC	12	39.4	27.5	F07	64	6.7
80	76	90	77.9	70	M8	188	145	250	3/4"-10UNC	12	39.4	27.5	F07	85	9.8
100	96	116	102	102	M10	224	179	323	1"-8UNC	16	53.7	39.8	F10	95	19.2

NPS	d	d1	d2	D	M	L	H	W	S	T	H1	H2	ISO 5211	Torque (in-lb)	Weight (lb)
1/4"	0.46	0.57	-	1.42	M5	2.56	2.3	3.94	3/8"-24UNF	0.2	0.76	0.53	F03	66.4	0.8
3/8"	0.49	0.71	-	1.42	M5	2.56	2.3	3.94	3/8"-24UNF	0.2	0.76	0.53	F03	66.4	0.8
1/2"	0.59	0.87	0.62	1.42	M5	2.56	2.44	3.94	3/8"-24UNF	0.2	0.76	0.53	F03	66.4	1.1
3/4"	0.79	1.08	0.82	1.42	M5	2.95	2.44	4.92	7/16"-20UNF	0.26	0.88	0.63	F03	66.4	1.6
1"	0.98	1.34	1.05	1.65	M5	3.35	3.03	5.87	7/16"-20UNF	0.31	1.01	0.64	F04	110.6	2.3
1-1/4"	1.26	1.69	1.38	1.65	M5	3.98	3.23	5.87	7/16"-20UNF	0.31	1.01	0.64	F04	132.8	3.6
1-1/2"	1.5	1.93	1.61	1.97	M6	4.41	3.94	7.48	1/2"-20UNF	0.39	1.17	0.79	F05	177	5.3
2"	1.97	2.4	2.07	1.97	M6	5.12	4.25	7.48	1/2"-20UNF	0.39	1.17	0.79	F05	221.3	7.7
2-1/2"	2.48	2.91	2.47	2.76	M8	6.38	5.39	9.84	3/4"-10UNC	0.47	1.55	1.08	F07	566.4	14.8
3"	2.99	3.54	3.07	2.76	M8	7.4	5.71	9.84	3/4"-10UNC	0.47	1.55	1.08	F07	752.3	21.6
4"	3.78	4.57	4.02	4.02	M10	8.82	7.05	12.72	1"-8UNC	0.63	2.11	1.57	F10	840.8	42.3

unit:mm

unit:in