



FEATURES

- Clamp end, 2-1/2"~4" (DN65~DN100)
- Body W.P. : 1000 WOG (PN63)
- Clamp End W.P. : 200 WOG
- W.T. : -20°C~200°C (-4°F~392°F)
- Investment casting
- Blow-out proof stem
- Live-loading design
- Anti-static device (option)
- Cavity filled seats (option)
- Locking device
- ISO 5211 Mounting pad

2013KC-BPE

- Clamp end castings have low sulphur content of 0.005-0.017%

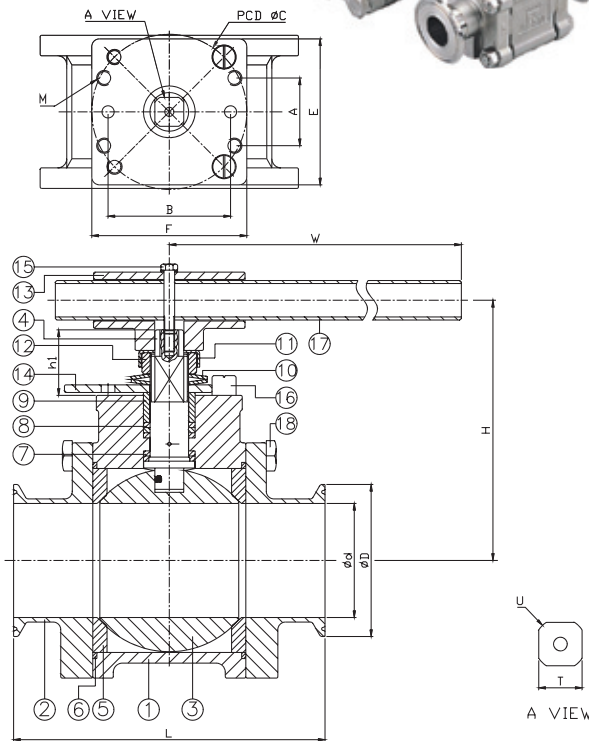

ITEM	PARTS	MATERIAL
1	BODY	ASTM A351-CF3M
2	CAP	
3	BALL	
4	STEM	ASTM A276-316L
5	SEAT	PTFE / TFM1600
6	SEAL	PTFE
7	THRUST WASHER	
8	PACKING	AISI 304
9	GLAND RING	
10	BELLEVILLE WASHER	AISI 301
11	LOCKING WASHER	AISI 304
12	STEM NUT	
13	WRENCH BLOCK	
14	STOPPER	
15	BOLT	
16	STOP PIN	
17	HANDLE	
18	BOLT	

DN	d	D	L	H	W	h1	M	A	B	C	E	F	T	U	ISO 5211	Torque (N-M)
65	60.2	77.4	159	132.1	222	40.6	M10	32	64	102	70.1	85.1	14	M20*2.5	F10	29
80	72.9	90.9	177.8	165.6	349	42.7	M10	44.5	80.5	102	96	102.1	19.1	1"-14UNEF	F10	35
100	97.3	118.9	215.9	179.1	349	42.9	M10	44.5	80.5	102	96	102.1	19.1	1"-14UNEF	F10	50

unit:mm

NPS	d	D	L	H	W	h1	M	A	B	C	E	F	T	U	ISO 5211	Torque (in-lb)
2-1/2"	2.37	2.5	6.26	5.2	8.74	1.6	M10	1.26	2.52	4.02	2.76	3.35	0.55	M20*2.5	F10	256.7
3"	2.87	3	7	6.52	13.74	1.68	M10	1.75	3.17	4.02	3.78	4.02	0.75	1"-14UNEF	F10	309.8
4"	3.83	4	8.5	7.05	13.74	1.69	M10	1.75	3.17	4.02	3.78	4.02	0.75	1"-14UNEF	F10	442.5

unit:in

