

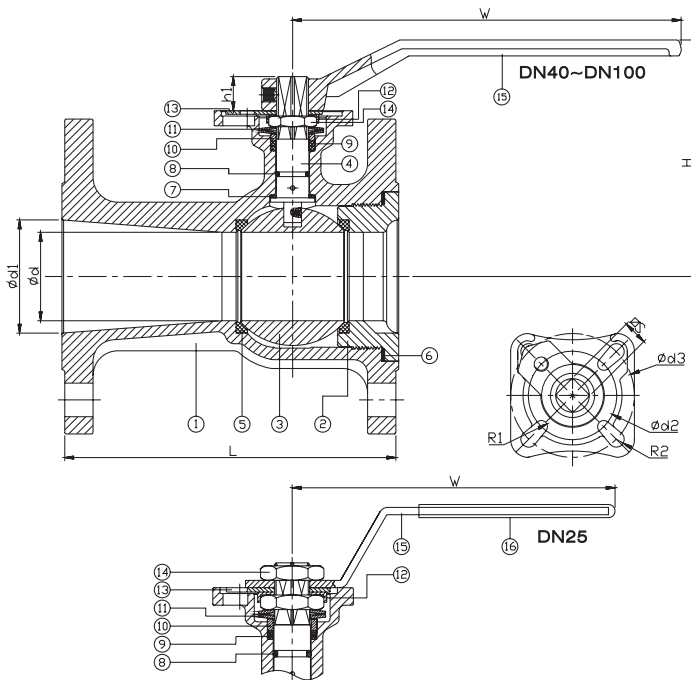

FEATURES

- Standard port, 1"~4" (DN25~DN100)
 - W.P. : CLASS 150
 - W.T. : -20°C~200°C (-4°F~392°F)
 - Investment casting
 - Blow-out proof stem
 - Live-loading design
 - Anti-static device
 - ISO 5211 Direct mounting pad
 - **API 607 Fire safe approved**
 - **Automation accessories (option)**
- Wall thickness: ASME B16.34
 - Flange dimension: ASME B16.5
 - Face to face: ASME B16.10



ITEM	PARTS	MATERIAL	
1	BODY	ASTM A351-CF8M	ASTM A216-WCB
2	RETAINER	ASTM A351-CF8M	
3	BALL	ASTM A276-316	
4	STEM	PTFE	
5	SEAT	GRAPHITE	
6	SEAL	CTFE	
7	THRUST WASHER	VITON	
8	O-RING	GRAPHITE	
9	PACKING		
10	GLAND RING		
11	BELLEVILLE WASHER		
12	LOCKING WASHER		
13	LOCKING PAD	AISI 304	
14	STEM NUT		
15	HANDLE	STAINLESS STEEL	
16	HANDLE SELLVE	PVC	

DN	d	d1	L	H	W	ISO 5211	S	h1	d2	d3	R1	R2	Torque (N-M)
25	20	25	127	80	117	F03/F04	9	8	36	42	2.75	2.75	9.8
40	30	40	165	90	160	F04/F05	11	10.5	42	50	2.75	3.5	20.8
50	38	50	178	117	221	F05/F07	14	14	50	70	3.5	4.5	29.9
65	50	64	190.5	130	221	F05/F07	14	15.5	50	70	3.5	4.5	37.7
80	64	76	203	134	325	F07/F10	17	18.5	70	102	4.5	5.5	48.1
100	76	100	229	157	325	F07/F10	17	20	70	102	4.5	5.5	55.9

unit:mm

NPS	d	d1	L	H	W	ISO 5211	S	h1	d2	d3	R1	R2	Torque (in-lb)
1"	0.79	0.98	5	3.15	4.61	F03/F04	0.35	0.32	1.42	1.65	0.11	0.11	86.7
1-1/2"	1.18	15.7	6.5	3.54	6.3	F04/F05	0.43	0.41	1.65	1.97	0.11	0.14	184.1
2"	1.5	1.97	7.01	4.61	8.7	F05/F07	0.55	0.55	1.97	2.76	0.14	0.18	264.6
2-1/2"	1.97	2.52	7.5	5.12	8.7	F05/F07	0.55	0.61	1.97	2.76	0.14	0.18	333.7
3"	2.52	2.99	7.99	5.28	12.8	F07/F10	0.67	0.73	2.76	4.02	0.18	4.02	425.7
4"	2.99	3.94	9.02	6.18	12.8	F07/F10	0.67	0.79	2.76	4.02	0.18	4.02	494.8

unit:in

