

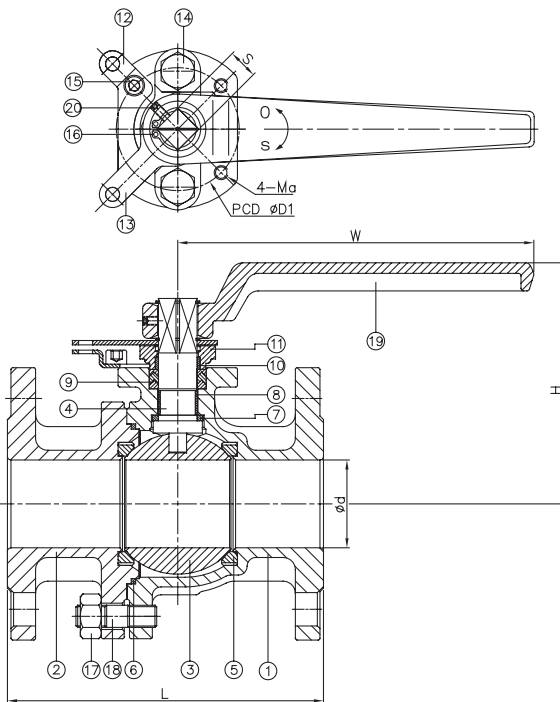

FEATURES

- Full port, 1/2"~8" (DN15~DN200)
- W.P. : 10K/20K
- W.T. : -20°C~200°C (-4°F~392°F)
- Investment casting
- Blow-out proof stem
- Anti-static device
- Locking device
- ISO 5211 Mounting pad

- Flange dimension: JIS B2220
- Face to face: JIS B2002



ITEM	PARTS	MATERIAL	
		SCS14	SCS13
1	BODY		
2	CAP		
3	BALL		
4	STEM	SUS 316	
5	BALL SEAT	RTFE	
6	BODY SEAL		
7	THRUST WASHER A	PTFE	
8	THRUST WASHER B		
9	PACKING A	SUS 304	
10	PACKING B		
11	GLAND		
12	BRACKET		
13	STOPPER		
14	BOLT		
15	BOLT		
16	CIRCLIPS FOR SHAFTS		
17	NUT		
18	STUD		
19	HANDLE	SCW 410	
20	SOCKET SET SCREWS	SUS 304	

DN	d	JIS 10K	JIS 20K	H	W	D1	S	Ma
		L	L					
15	15	110	140	77	130	42	11	1/4"-20UNC
20	20	120	152	80	130	42	11	1/4"-20UNC
25	25	130	165	90	163	50	14	1/4"-20UNC
32	32	140	178	98.5	163	50	14	1/4"-20UNC
40	40	165	190	129	203	70	17	5/16"-18UNC
50	50	180	216	136	203	70	17	5/16"-18UNC
65	65	190	241	159	203	70	17	5/16"-18UNC
80	80	200	283	173.5	327	102	22	3/8"-16UNC
100	100	230	305	196	327	102	22	3/8"-16UNC

unit:mm

NPS	d	JIS 10K	JIS 20K	H	W	D1	S	Ma
		L	L					
1/2"	0.59	4.33	5.51	3.03	5.12	1.65	0.43	1/4"-20UNC
3/4"	0.79	4.72	5.98	3.15	5.12	1.65	0.43	1/4"-20UNC
1"	0.98	5.12	6.5	3.54	6.42	1.97	0.55	1/4"-20UNC
1-1/4"	1.26	5.51	7.01	3.88	6.42	1.97	0.55	1/4"-20UNC
1-1/2"	1.57	6.5	7.5	5.08	7.99	2.76	0.67	5/16"-18UNC
2"	1.97	7.09	8.5	5.35	7.99	2.76	0.67	5/16"-18UNC
2-1/2"	2.56	7.48	9.49	6.26	7.99	2.76	0.67	5/16"-18UNC
3"	3.15	7.87	11.14	6.83	12.87	4.02	0.87	3/8"-16UNC
4"	3.94	9.06	12.01	7.72	12.87	4.02	0.87	3/8"-16UNC

unit:in

