



# 3/4-WAY FLANGED END BALL VALVE

# 2059



## FEATURES

- **L port / T port**, 1/2"~6" (DN15~DN150)
- W.P. : PN16/40  
CLASS 150/300  
JIS 10k
- W.T. : -20°C~200°C (-4°F~392°F)
- Investment casting
- Blow-out proof stem
- ISO 5211 Mounting pad

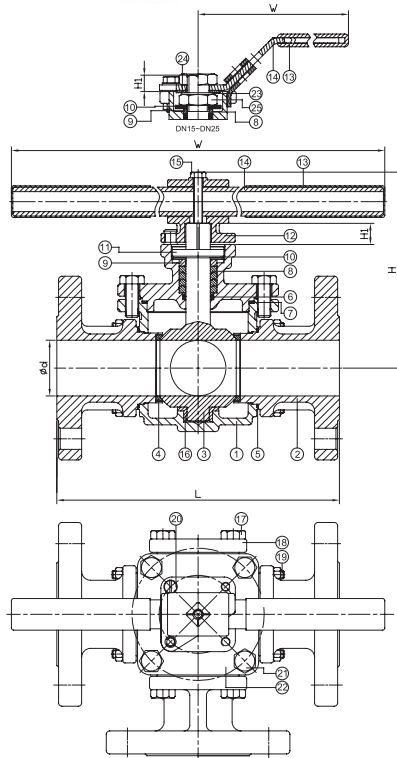

ITEM	PARTS	MATERIAL	
1	BODY	ASTM A351-CF8M	ASTM A351-CF8
2	CAP		
3	BALL & STEM		
4	SEAT	PTFE	
5	SEAL	VITON	
6	O-RING	PTFE	
7	GASKET	VITON	
8	PACKING	PTFE	
9	GLAND RING	AISI 304	
10	SPRING WASHER	AISI 304	
11	CAP-C	ASTM A351-CF8M	ASTM A351-CF8
12	HANDLE HEAD	ASTM A351-CF8	
13	HANDLE SLEEVE	PVC	
14	HANDLE	AISI 304	
15	HANDLE BOLT	AISI 304	
16	SLEEVE	PTFE	
17	CAP-B BOLT	AISI 304	
18	CAP-B	ASTM A351-CF8M	ASTM A351-CF8
19	BOLT	AISI 304	
20	STOP PIN	AISI 304	
21	CAP-A BOLT	AISI 304	
22	CAP-A	ASTM A351-CF8M	ASTM A351-CF8
23	LOCKING WASHER	AISI 304	
24	HANDLE WASHER	AISI 304	
25	STEM NUT	AISI 304	

DN	d	CLASS 150	CLASS 300	PN 16/40	JIS 10K	H	H1	W	Torque (N-M)
		L	L	L	L				
15	15	148	160	160	160	80	9	123	22.9
20	20	153	165	165	165	84	9	123	27.3
25	25	168	180	180	180	96	11	153	31.2
32	32	221	221	234	221	171	19	403	39
40	40	221	221	234	221	171	19	403	39
50	50	254	254	273	254	176	19	403	83.2
65	65	300	300	300	300	198	24	504	91
80	76	305	305	305	305	216	24	504	187.2
100	96	369	369	369	369	236	24	504	234
150	148	480	495	480	480	329	38	800	442

unit:mm

NPS	d	CLASS 150	CLASS 300	PN 16/40	JIS 10K	H	H1	W	Torque (in-lb)
		L	L	L	L				
1/2"	0.59	5.83	6.3	6.3	6.3	3.15	0.35	4.84	202.7
3/4"	0.79	6.02	6.50	6.5	6.5	3.31	0.35	4.84	241.6
1"	0.98	6.61	7.09	7.09	7.09	3.78	0.43	6.02	276.1
1-1/4"	1.26	8.7	8.70	9.21	8.7	6.73	0.75	15.87	345.2
1-1/2"	1.57	8.7	8.70	9.21	8.7	6.73	0.75	15.87	345.2
2"	1.97	10	10	10.75	10	6.93	0.75	15.87	736.4
2-1/2"	2.56	11.81	11.81	11.81	11.81	7.8	0.94	19.84	805.4
3"	2.99	12.01	12.01	12.01	12.01	8.5	0.94	19.84	1656.9
4"	3.78	14.53	14.53	14.53	14.53	9.29	0.94	19.84	2071.1
6"	5.83	18.9	19.49	18.9	18.9	12.95	1.5	31.5	3912

unit:in



8F., No.201, Sec. 2, Tiding Blvd., Neihu District, Taipei City 114, Taiwan R.O.C.  
 TEL : +886-2-2658-5800 FAX : +886-2-2658-2266 / 2799-7766

[Http://www.haitima.com.tw](http://www.haitima.com.tw)  
 E-mail : [haitima@seed.net.tw](mailto:haitima@seed.net.tw)