

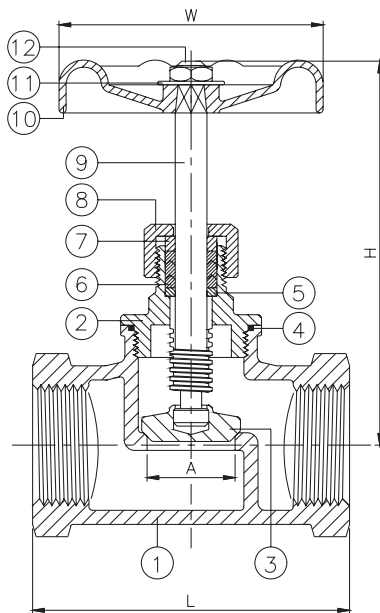

FEATURES

- 1/4"~2" (DN8~DN50)
- W.P. : 200 WOG
- W.T. : -20°C~200°C (-4°F~392°F)
- Investment casting
- Rising stem
- Thread type : ASME B1.20.1 (NPT)
DIN2999 & BS21
ISO7/1 & EN10226



ITEM	PARTS	MATERIAL
1	BODY	ASTM A351-CF8M
2	BONNET	
3	DISC	
4	SEAL	PTFE
5	WASHER	AISI 304
6	PACKING	PTFE
7	GLAND RING	AISI 304
8	CAP NUT	AISI 316
9	STEM	
10	HANDLE	ALUMINUM
11	NAMEPLATE	
12	STEM NUT	AISI 304

DN	L	H	W	A	Weight (kg)
15	52	105.5	70	13.6	0.3
20	52	105.5	70	13.6	0.3
25	52	107	70	13.6	0.3
40	66	116	80	17.6	0.5
50	76	129.2	80	22.6	0.7
65	86	153.5	90	29.5	1
80	94	157	100	30.5	1.3
100	118	172	100	42.5	1.8

unit:mm

NPS	L	H	W	A	Weight (lb)
1/2"	2.05	4.15	2.76	0.54	0.7
3/4"	2.05	4.15	2.76	0.54	0.7
1"	2.05	4.21	2.76	0.54	0.7
1-1/2"	2.6	4.57	3.15	0.69	1
2"	2.99	5.09	3.15	0.89	1.5
2-1/2"	3.39	6.04	3.54	1.16	2.2
3"	3.7	6.18	3.94	1.2	2.8
4"	4.65	6.77	3.94	1.67	4

unit:in

