

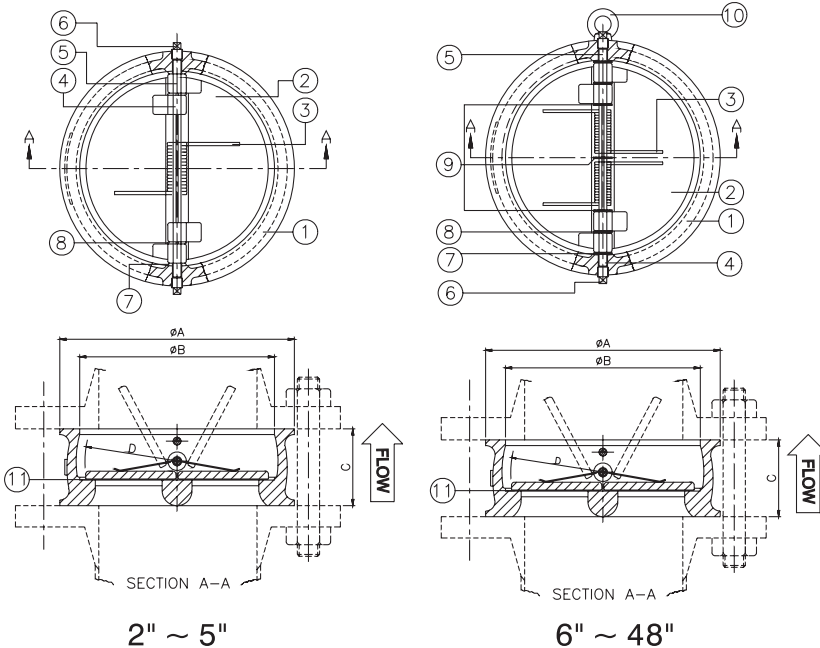

FEATURES

- 2"~48" (DN50~DN1200)
- W.P. : PN10/16/40
CLASS 150/300/600
- W.T. : -20°C~200°C (-4°F~392°F)
- Investment casting
- Metal to metal (option)



ITEM	PARTS	MATERIAL
1	BODY	ASTM A351-CF8M
		ASTM A216-WCB
		DUCTILE IRON
2	PLATE	ASTM A216-WCB / ASTM A351-CF8
		ASTM A351-CF8M / ASTM A351-CF3M
3	SPRING	AISI 316 WPA
4	HINGE PIN	AISI 304 / AISI 316
5	STOP PIN	
6	PLUG	S25C
7	BODY BEARING	TEFLON
8	PLATE BEARING	
9	SPRING BEARING	
10	EYE BOLT	SS41
11	BODY SEAT	NBR / EPDM / VITON
		SAME MATERIALS AS THE PLATE
		410SS OVERLAY / STELLITY #6 OVERLAY

PN16 ONLY, OTHER PRESSURE RATING PLEASE CONTACT US.

DN	A	B	C	D	Weight (kg)
50	109	60	54	32	3
65	129	73	54	37	4
80	144	89	57	45	5
100	164	114	64	53	6
125	194	141	70	67	9
150	220	168	76	79	10
200	275	219	95	105	19
250	331	273	108	123	31
300	386	324	143	155	56
350	446	356	184	170	71
400	498	406	191	195	99
450	558	457	203	219	118
500	620	508	213	244	180
600	737	610	222	292	258
700	807	711	321	337	580
800	914	813	356	397	526
900	1014	914	368	440	656
1000	1131	1016	419	495	1010
1200	1345	1219	524	603	1926

unit:mm

NPS	A	B	C	D	Weight (kg)
2"	4.29	2.36	2.13	1.26	6.6
2-1/2"	5.08	2.87	2.13	1.46	8.8
3"	5.67	3.50	2.24	1.77	11
4"	6.46	4.49	2.52	2.09	13.2
5"	7.64	5.55	2.76	2.64	19.8
6"	8.66	6.61	2.99	3.11	22
8"	10.83	8.62	3.74	4.13	41.9
10"	13.03	10.75	4.25	4.84	68.3
12"	15.20	12.76	5.63	6.10	123.4
14"	17.56	14.02	7.24	6.69	156.5
16"	19.61	15.98	7.52	7.68	218.2
18"	21.97	17.99	7.99	8.62	260.1
20"	24.41	20.00	8.39	9.61	396.7
24"	29.02	24.02	8.74	11.50	568.6
28"	31.77	27.99	12.64	13.27	1278.3
32"	35.98	32.01	14.02	15.63	1159.3
36"	39.92	35.98	14.49	17.32	1445.8
40"	44.53	40.00	16.50	19.49	2226
48"	52.95	47.99	20.63	23.74	4244.9

unit:in