

Item description/product images



Description

Material:

Thread sleeve stainless 1.4305.

Indexing pin stainless 1.4305.

Mushroom knob stainless 1.4305.

Version:

Threaded sleeve, bright.

Indexing pin, ground.

Mushroom knob, electrolytic polished.

Note:

Indexing plungers are used where any change in locking position due to lateral forces should be prevented. A new locking position can only be attained after the pin has been manually disengaged. A screw-in washer is available to aid by screwing the plunger in. This washer is slipped under the raised knob and the carrier pins fit into the slots.

On request:

Special versions.

Drawings

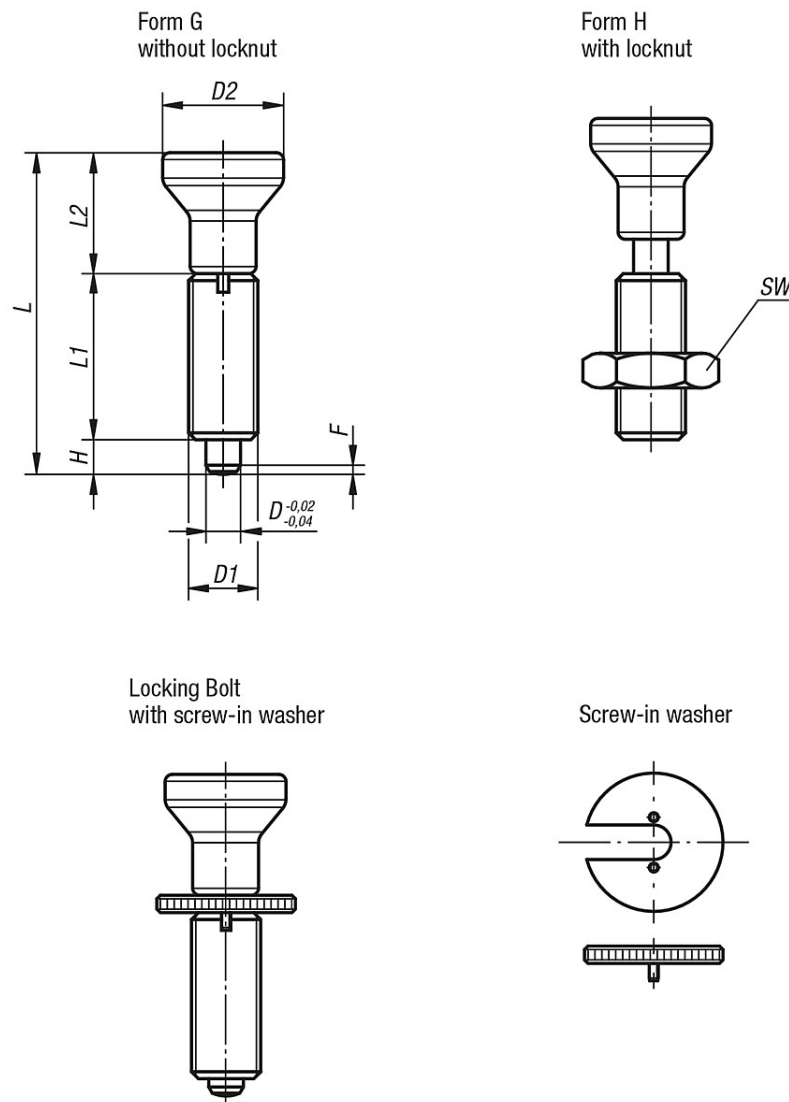

Overview of items

Order No.	Version	Form	Size	D	D1	D2	L	L1	L2	H	SW	F x 30°	Spring force initial pressure F1 approx. N	Spring force final pressure F2 approx. N	Order No. screw-in washer
30-62-1	locking pin hardened	G	0	4	M8x1	18	43	21	18	4	-	1	6	12	950-024-9000
30-62-2	locking pin hardened	G	1	5	M10x1	21	50	24	21	5	-	1,3	5	12	950-024-9001
30-62-3	locking pin hardened	G	2	6	M12x1,5	25	59	28	25	6	-	1,8	6	14	950-024-9002
30-62-4	locking pin hardened	G	3	8	M16x1,5	33	77	36	33	8	-	2,3	15	35	950-024-9003
30-62-5	locking pin hardened	G	4	10	M20x1,5	33	83	40	33	10	-	2,8	15	34	950-024-9004
30-63-1	locking pin hardened	H	0	4	M8x1	18	43	21	18	4	13	1	6	12	950-024-9000
30-63-2	locking pin hardened	H	1	5	M10x1	21	50	24	21	5	17	1,3	5	12	950-024-9001
30-63-3	locking pin hardened	H	2	6	M12x1,5	25	59	28	25	6	19	1,8	6	14	950-024-9002
30-63-4	locking pin hardened	H	3	8	M16x1,5	33	77	36	33	8	24	2,3	15	35	950-024-9003
30-63-5	locking pin hardened	H	4	10	M20x1,5	33	83	40	33	10	30	2,8	15	34	950-024-9004
30-64-1	locking pin not hardened	G	0	4	M8x1	18	43	21	18	4	-	1	6	12	950-024-9000
30-64-2	locking pin not hardened	G	1	5	M10x1	21	50	24	21	5	-	1,3	5	12	950-024-9001
30-64-3	locking pin not hardened	G	2	6	M12x1,5	25	59	28	25	6	-	1,8	6	14	950-024-9002
30-64-4	locking pin not hardened	G	3	8	M16x1,5	33	77	36	33	8	-	2,3	15	35	950-024-9003
30-64-5	locking pin not hardened	G	4	10	M20x1,5	33	83	40	33	10	-	2,8	15	34	950-024-9004
30-65-1	locking pin not hardened	H	0	4	M8x1	18	43	21	18	4	13	1	6	12	950-024-9000
30-65-2	locking pin not hardened	H	1	5	M10x1	21	50	24	21	5	17	1,3	5	12	950-024-9001

Overview of items

Order No.	Version	Form	Size	D	D1	D2	L	L1	L2	H	SW	F x 30°	Spring force initial pressure F1 approx. N	Spring force final pressure F2 approx. N	Order No. screw-in washer
30-65-3	locking pin not hardened	H	2	6	M12x1,5	25	59	28	25	6	19	1,8	6	14	950-024-9002
30-65-4	locking pin not hardened	H	3	8	M16x1,5	33	77	36	33	8	24	2,3	15	35	950-024-9003
30-65-5	locking pin not hardened	H	4	10	M20x1,5	33	83	40	33	10	30	2,8	15	34	950-024-9004

Order No.	Article description
950-024-9000	Screw-in washer for Locking Bolt 30-62-1/30-63-1/30-64-1/30-65-1
950-024-9001	Screw-in washer for Locking Bolt 30-62-2/30-63-2/30-64-2/30-65-2
950-024-9002	Screw-in washer for Locking Bolt 30-62-3/30-63-3/30-64-3/30-65-3
950-024-9003	Screw-in washer for Locking Bolt 30-62-4/30-63-4/30-64-4/30-65-4
950-024-9004	Screw-in washer for Locking Bolt 30-62-5/30-63-5/30-64-5/30-65-5