

**Item description/product images**



**Description**

**Material:**

Race body and cage stainless steel 1.4125.  
 Bearing balls ZrO<sub>2</sub> or Si<sub>3</sub>N<sub>4</sub>.

**Version:**

Bright.

**Note:**

Hybrid ball bearings (steel body and cage, ceramic balls) are a technical and cost effective alternative in cases where steel ball bearings are insufficient, and all ceramic ball bearings are too expensive. Higher speeds can be achieved in comparison to steel bearings. The bearing balls are lighter and, because of the lower friction require less lubrication. They also have a longer service life.

**On request:**

Without ball cage.

**Drawings**

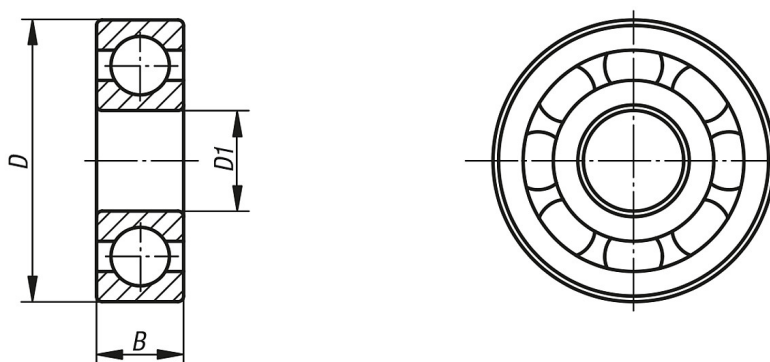

**Overview of items**

Order No.	Version	B	D	D1	Dynamic base loads kN	Static base loads kN	max. speed U/min
50-401-1	Bearing balls ZrO <sub>2</sub>	7	22	8	2	1	37.000
50-401-2	Bearing balls ZrO <sub>2</sub>	8	26	10	3	1,4	31.000
50-401-3	Bearing balls ZrO <sub>2</sub>	8	28	12	3,3	1,7	29.000
50-401-4	Bearing balls ZrO <sub>2</sub>	9	32	15	3,6	2,1	24.000
50-401-5	Bearing balls ZrO <sub>2</sub>	10	35	17	3,9	2,3	21.000
50-401-6	Bearing balls ZrO <sub>2</sub>	12	42	20	6	3,7	18.000
50-401-7	Bearing balls ZrO <sub>2</sub>	12	47	25	6,5	5,8	15.000
50-401-8	Bearing balls ZrO <sub>2</sub>	13	55	30	8,5	7,6	12.500
50-402-1	Bearing balls Si <sub>3</sub> N <sub>4</sub>	7	22	8	2,3	1,1	41.000
50-402-2	Bearing balls Si <sub>3</sub> N <sub>4</sub>	8	26	10	3,3	1,6	34.000
50-402-3	Bearing balls Si <sub>3</sub> N <sub>4</sub>	8	28	12	3,6	1,9	32.000
50-402-4	Bearing balls Si <sub>3</sub> N <sub>4</sub>	9	32	15	4	2,3	27.000
50-402-5	Bearing balls Si <sub>3</sub> N <sub>4</sub>	10	35	17	4,3	2,6	23.000
50-402-6	Bearing balls Si <sub>3</sub> N <sub>4</sub>	12	42	20	6,7	4,1	20.000
50-402-7	Bearing balls Si <sub>3</sub> N <sub>4</sub>	12	47	25	7,2	4,8	17.000
50-402-8	Bearing balls Si <sub>3</sub> N <sub>4</sub>	13	55	30	9,4	6,8	14.000

**Overview of items**

---