



Autobroil™

Models 2424(G) 121224(G)

Straight Through Conveyor Broilers

Item No: _____

AIA FILE NO. / SPEC NO.

CONSULTANT / CONTRACTOR APPROVAL



Model 121224(G)

Marshall Models 2424(G) and 121224(G) Gas and Electric Broilers are designed for high volume hamburger or meat file production. The 1000° plus metal infrared heat source broils the meat quickly, giving the advantage of speed, plus sealing in juices for better taste.

Model 2424(G) has two 24" belts, one for broiling and one for contact toasting. Model 121224(G) has two 12" broiling belts and one 24" belt for contact toasting, which allows for different cooking speeds and menu flexibility. In both models, food is loaded at the front of broiler or toaster and is automatically delivered to holding trays at rear.

All Marshall products are supported by a nationwide service organization and in-house, full-time Customer Support Department. To place an order call:

1-800-627-8368

**ETL (US, Canada) & NSF Listed
FOR COMMERCIAL USE ONLY**

**Ask about Marshall's ThermoGlo™ Food Warmers,
companion High Speed Toasters, and Ventilation Systems*

Marshall's largest capacity, high production hamburger and meat file broilers. High temperature infrared heat and direct on-conveyor broiling for speed, flavor enhancement and bar marks.

FEATURES

- An integrated control features 6 menu item programs on single belt and 3 per belt on dual belt broilers (time & temperature)
- Control features broiled self-diagnostics
- Optional on-board food probe
- Front return cooking arrangement - Fully automatic
- Electronic ignition (gas) – Simply use the on/off switch
- Individual plug-in motors and speed control selectors for each broiler belt
- Convenient functional patty/bun assembly area with ThermoGlo™ technology
- Less removable parts allow fast and easy clean up
- Energy- saving pilot shut-off system (gas)
- Built-in bun toaster

CONSTRUCTION

- Heavy gauge stainless steel solid weld frame construction
- 3/16" diameter, heavy-duty stainless steel conveyor rods
- Stainless steel internal gas lines (gas models)
- Simple conveyor tension adjustment
- Easy to operate computer control panel
- Heavy duty industrial grade heating elements or gas burners

VOLUME

Hamburger Peak Production:

Frozen 2 oz. patties 850/hr.

4 oz. patties 510/hr.

Fresh 2 oz. patties 1,060/hr.

4 oz. patties 640/hr.

Buns Exceeds burger production

(Figures for estimating only. Actual production varies with fat content, surface texture and meat starting temperature.)

Marshall Air Systems, Inc.

419 Peachtree Drive South • Charlotte, North Carolina 28217 USA • Phone: (704) 525-6230 Fax: (704) 525-6229 • www.marshallair.com



Autobroil™

Models 2424 (G) & 121224 (G)

Straight Through Conveyor Gas & Electric Broilers

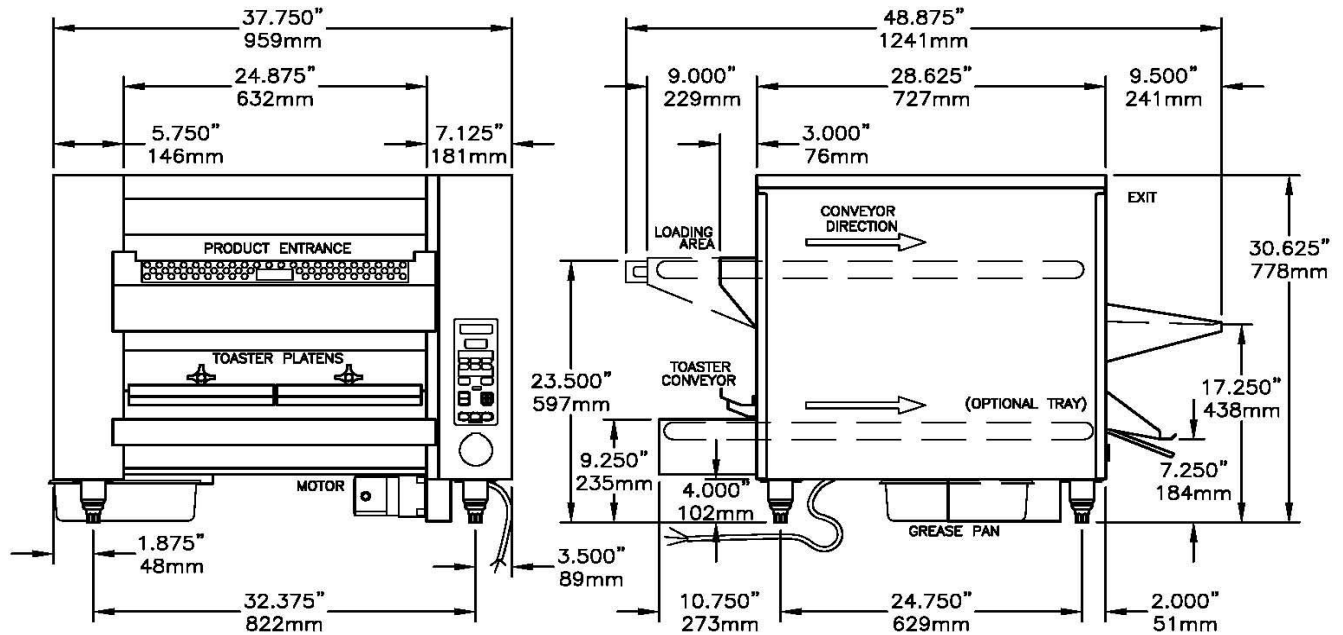

Overall Dimensions Model 2424 (G) & 121224 (G)

Dimensions:	Height: 30.625" 778mm	Width: 37.750" 959mm	Depth: 48.875" (with 9" loading arms) 1241mm	
Shipping Information:	Weight: Net 485 lbs. 207 kg	Ship Wt: 525 lbs. 239 kg	Freight (USA) NMFC Class 85	Ship. Cubes: 58.2 cubic ft. 1.65 cubic meters
Electrical:	Electric Units 208V/60Hz/3 ph 64 amps/ 18.5 kw (L1,L2,L3,G) 380V/50Hz/3 ph 42 amps/ 22 kw (L1,L2,L3,N,G)		Gas Units 208-240V/60Hz/1 ph 19 amps/ 3.952 kw (L1,L2,N,G) 240V/50Hz/1 ph 22 amps/ 5.280 kw (L1,N,G)	
Gas Supply:	N/A		97,000 BTUH – LP or Nat. 3/4" NPT Supply	
Options:	Autocat™ - Catalytic Converter (gas units only) Autoloader™ - Automatic Loading System Heavy-duty stainless steel stand with casters Other international voltages available 48" Flexible gas line with quick disconnect and restraining device (gas units only) Food probe		Extended Loading Arms Companion Ventilation System Complete spare parts supply kit	

Marshall Air Systems, Inc.

419 Peachtree Drive South • Charlotte, North Carolina 28217 USA • Phone: (704) 525-6230 Fax: (704) 525-6229 • www.marshallair.com