

NOTE 3

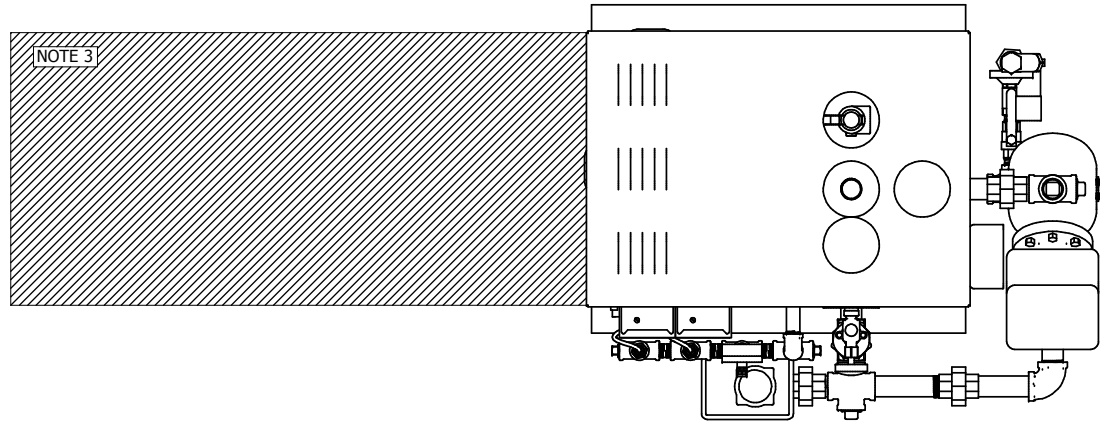

TOP VIEW

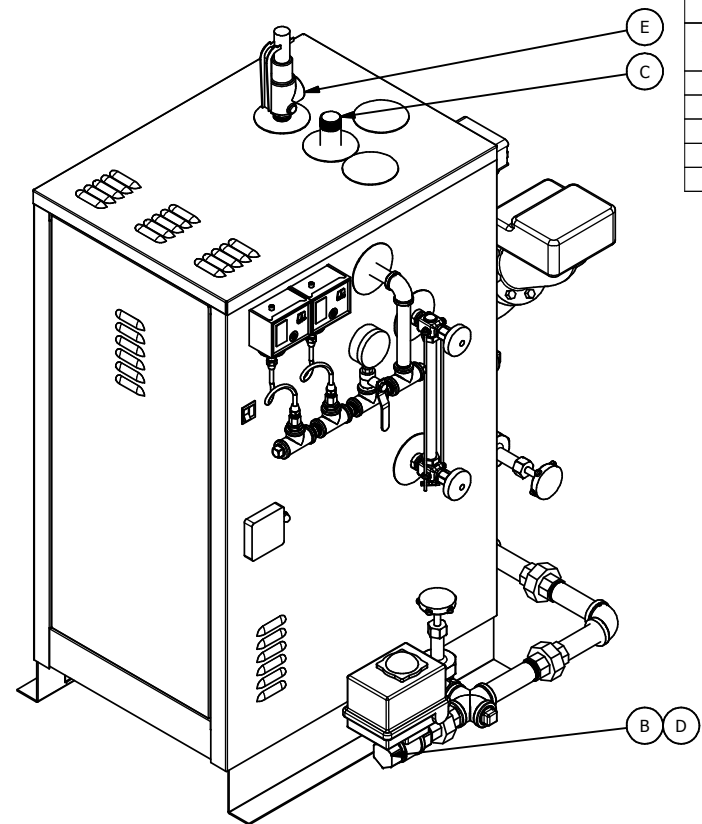

ISOMETRIC VIEW

CUSTOMER CONNECTIONS				
ITEM	DESCRIPTION	SIZE (100 PSI TRIM)	SIZE (15 PSI TRIM)	TYPE
A	FEED WATER INLET	1/2"	1/2"	N.P.T.
B	BLOWDOWN OUTLET	1"	1"	N.P.T.
C	STEAM OUTLET	1"	1"	N.P.T.
D	WATER COLUMN DRAIN	1"	1"	N.P.T.
E	SAFETY RELIEF VALVE	1"	3/4"	N.P.T.

EQUIPMENT SPECIFICATION CHART	
TYPE:	ELECTRIC
MAX ALLOWABLE WORKING PRESSURE:	100 PSI
BOILER OUTPUT:	163,693 BTU/HR
STEAM OUTPUT/MIN. SRV CAPACITY:	169 LBS/HR
NUMBER OF ELEMENTS (WATTAGE PER ELEMENT):	1 (12 kW), 2 (18 kW)
WATER CAPACITY (OPERATING):	9 GAL.
APPROXIMATE DRY WEIGHT:	356 LBS.
APPROXIMATE OPERATING WEIGHT:	431 LBS.
APPROXIMATE SHIPPING WEIGHT:	360 LBS.
APPROXIMATE FLOODED WEIGHT:	475 LBS.

ELECTRICAL REQUIREMENTS	
VOLTAGE	OPERATING FLA
208/60/3	134 AMPS
240/60/3	116 AMPS
380/60/3	73 AMPS
480/60/3	59 AMPS
600/60/3	47 AMPS

NOTE: OPERATING FULL LOAD AMPERAGE (FLA) REFERS TO THE BOILER'S RATED CURRENT DRAW AT HIGH FIRE.

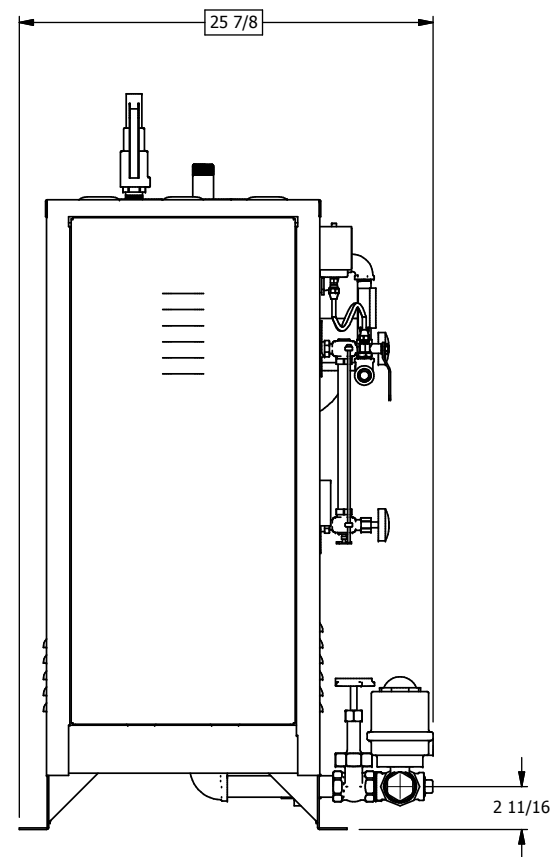

FRONT VIEW

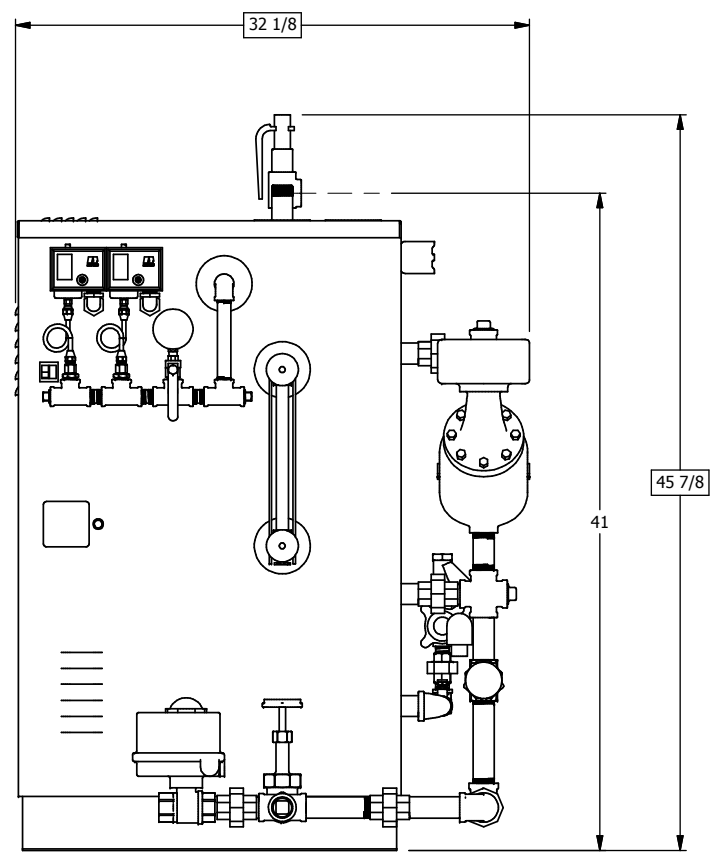

SIDE VIEW

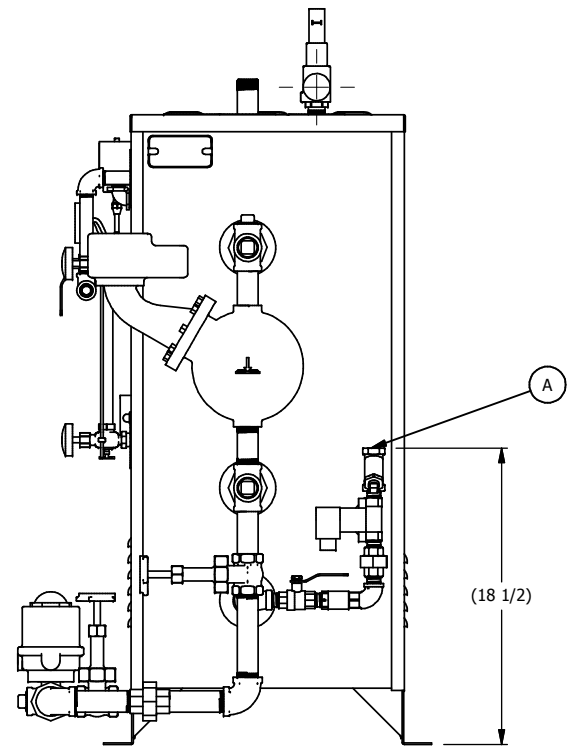

BACK VIEW

- NOTES:
- STEAM OUTPUT LB/HR: FROM 0 PSIG AT 212°F (0 KG/CM² AT 100°C)
 - ALL CLEARANCES ARE FACTORY RECOMMENDATIONS. CONSULT LOCAL JURISDICTION FOR EXACT CODE COMPLIANCE.
 - FULTON RECOMMENDS MINIMUM CLEARANCE OF 36" IN FRONT OF ELECTRICAL PANELS AND 24" AROUND SIDES OF BOILER.
 - PLEASE REFER TO THE O&M MANUAL FOR ADDITIONAL INFORMATION REGARDING CLEARANCES AND INSTALLATION INSTRUCTIONS.
 - ALL DIMENSIONS INSIDE () DENOTE REFERENCE DIMENSIONS.
 - ALL DIMENSIONS INSIDE □ DENOTE OVERALL DIMENSIONS.
 - WE RESERVE THE RIGHT TO CHANGE SPECIFICATIONS AND/OR DIMENSIONS. ALL INFORMATION IS SUBJECT TO CHANGE BASED ON ADDITION OF ANY OPTIONAL EQUIPMENT AND/OR ACCESSORIES. PLEASE CONSULT THE FACTORY FOR PROJECT SPECIFIC ESTIMATES IF ADDITIONAL OPTIONS OR ACCESSORIES ARE REQUIRED.
 - SAFETY RELIEF VALVE SIZING IS BASED ON 100 PSIG TRIM. OTHER TRIM PRESSURES WILL CHANGE SAFETY VALVE SIZE.

REV	REVISION DESCRIPTION	B.O.M.	ELEC. ENG	MECH. ENG	CHECKED	APPROVED
-	INITIAL RELEASE	----	----	----	----	----
REVISION HISTORY						

UNLESS OTHERWISE NOTED, DIMENSIONS ARE IN INCHES.
 TOLERANCES:
 FRACTION & WHOLE VALUE ± 1/8
 (1) PLACE DEC. ± 0.03
 (2) PLACE DEC. ± 0.015
 (3) PLACE DEC. ± 0.005
 ANGLE ± 0.5 DEG
 SURFACE FINISH 250 MICRO-INCHES

This design and drawings are proprietary and are the exclusive property of Fulton Group N.A., Inc. The corporation does not permit their use except with prior written consent.

The items shown in this drawing may be covered by one or more patents of Fulton Group N.A., Inc.

DRAWN BY: C. AUSTIN	7/21/2016	MECH. ENG: EBW	7/28/2016	JOB NUMBER:
CHECKED BY:		ELEC. ENG:		PROJECT NAME:
B.O.M. REVIEW		APPROVED BY: WW	7/29/2016	PROJECT MANAGER:

DESCRIPTION:
FB-048E 48 KW HIGH PRESSURE ELECTRIC STEAM BOILER (100 PSI DESIGN)

Fulton Group N.A., Inc
 972 Centerville Road
 Pulaski, New York USA 13142

DRAWING NUMBER: **9-FBE-048PDS**

SHEET 1 OF 1