

AFC /AFCS

Top Load Carton Former

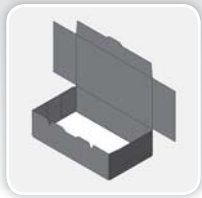

where products meet packaging®

Designed to form glued or lock style trays and tri-seal cartons, the versatile ADCO AFC family of top load carton formers are capable of forming a wide range of carton sizes and styles at up to 40 cycles per minute, depending on the configuration. With available servo-control (AFCS) and its heavy duty welded frame and drive system; these reliable formers are built to withstand the rigors of the most demanding production environments. Ideal for Retail Ready packaging applications, the flexible and adaptable AFC formers feature quick change forming heads, pick-and-place carton feed design and a shuttle style carton transfer system to provide efficient, reliable and forgiving operation. Like all ADCO machines, the AFC family of formers are constructed in stainless steel and are available in standard or washdown configurations.

Benefits

- Stainless steel construction improves cleanability
- Heavy-duty construction reduces maintenance and maximizes uptime.
- Fast, easy changeover reduces downtime and increases productivity
- Large carton size range and style range protects your investment as products change
- Easy integration to other ADCO top load machinery saves time and money
- Advanced guard design keeps operators safe and maximizes maintenance access

AFC/AFCS Top Load Carton Former

Product Features

- Stainless steel construction
- Available with up to three (3) forming heads
- Compact frame with leveling feet and casters
- Quick change plunger, forming cavity, magazine frame and pick bar
- Overload detent system for jam protection
- Pick-and-place carton feed system
- Shuttle style carton transfer system
- Nordson® ProBlue hot melt glue system with pattern control (when glue is specified)
- Allen-Bradley® control package with touch screen HMI interface
- Category 3 safety system with fully-interlocked barrier guard package
- Foot switch or photo-eye vacuum control
- Many options available upon request



Typical Applications

- Snack foods
- Baked goods in trays
- Flow-wrapped products
- Frozen meats
- Dairy
- Household products

Utilities

Electrical

230/460 VAC, 3-Phase with ground (PE), 60 Hz

Air Consumption

10 CFM @ 70 PSI

PLAN VIEW - AFC

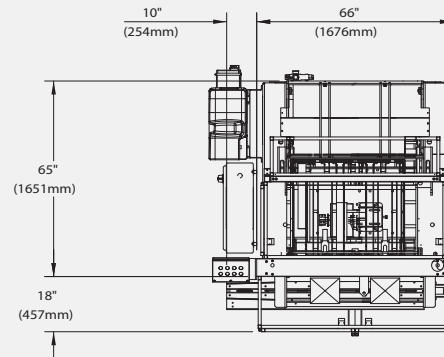

PLAN VIEW - AFCS

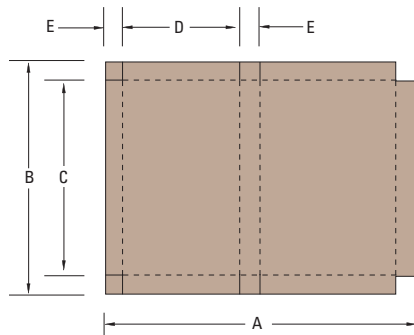
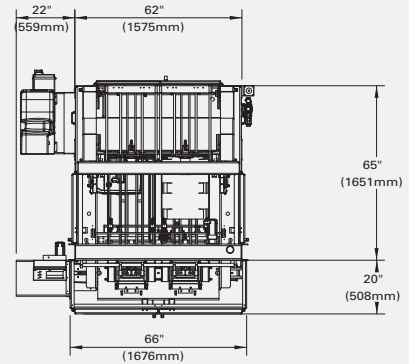

CARTON SIZE RANGE

Dimensions	(in)		(mm)	
	Min	Max	Min	Max
A	7.5	23	190	585
B	5	26	130	660
C	3	17	75	430
D	3	8	75	200
E	.75	4.5	19	115

Not all minimums and maximums apply.
Special modifications are available to extend the size range.



For more information on this product, scan the QR code with your mobile device.